

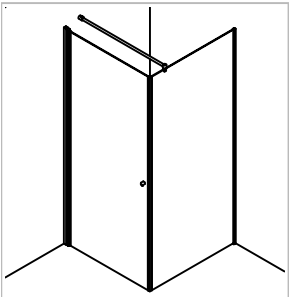

Technische Daten:
Hebe-Senk Dusche (Set) - Ecke einseitig

Datasheet:
Lift-off shower (set) - corner one-sided

Art. 29.4016.002.10
Art. 29.4016.002.26
Art. 29.4016.002.46

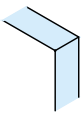

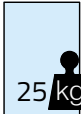
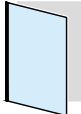
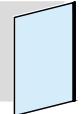
Ausführung: Options:	 6 mm	 900 mm max.	 25 kg max.	 DIN links/left + DIN rechts/right 
Material: Material:	Aluminium aluminum		Gewicht: / Weight: 5,6 kg	
Oberflächen: Finish:	silber matt eloxiert silver matt anodised	Chrom-Design Chrome design	Anthrazit-Design Anthracite design	

Im Lieferumfang enthalten:
Scope of supply:

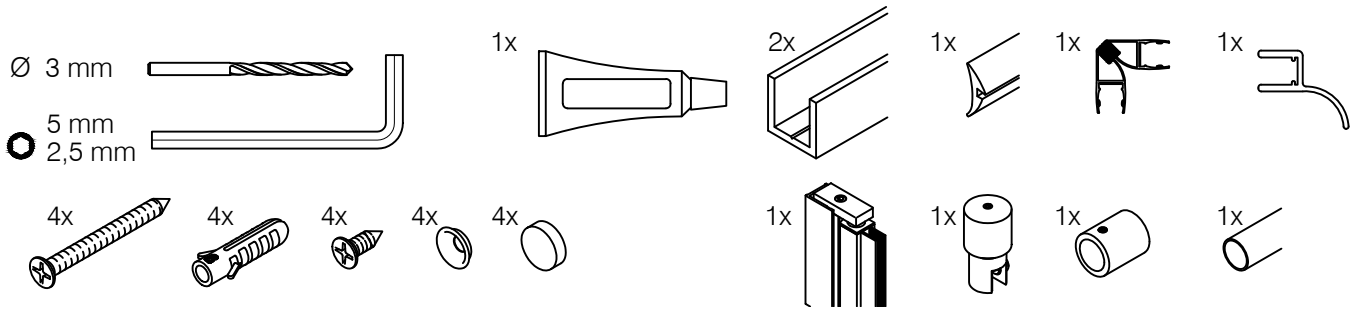

Montagewerkzeug:
Mounting tools:

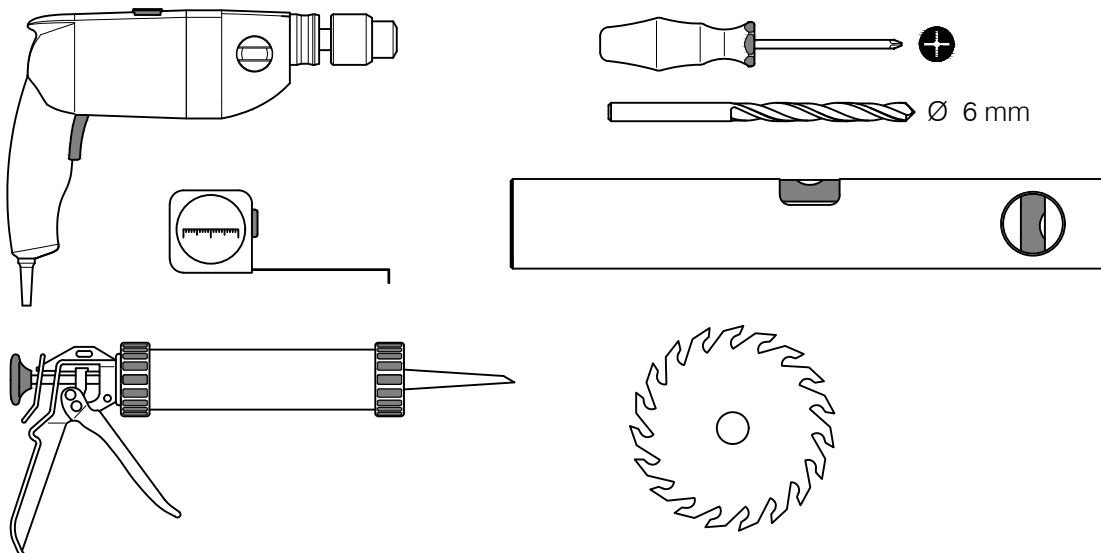

Art. 29.4016.002.10
 Art. 29.4016.002.26
 Art. 29.4016.002.46

Stand 10.2021

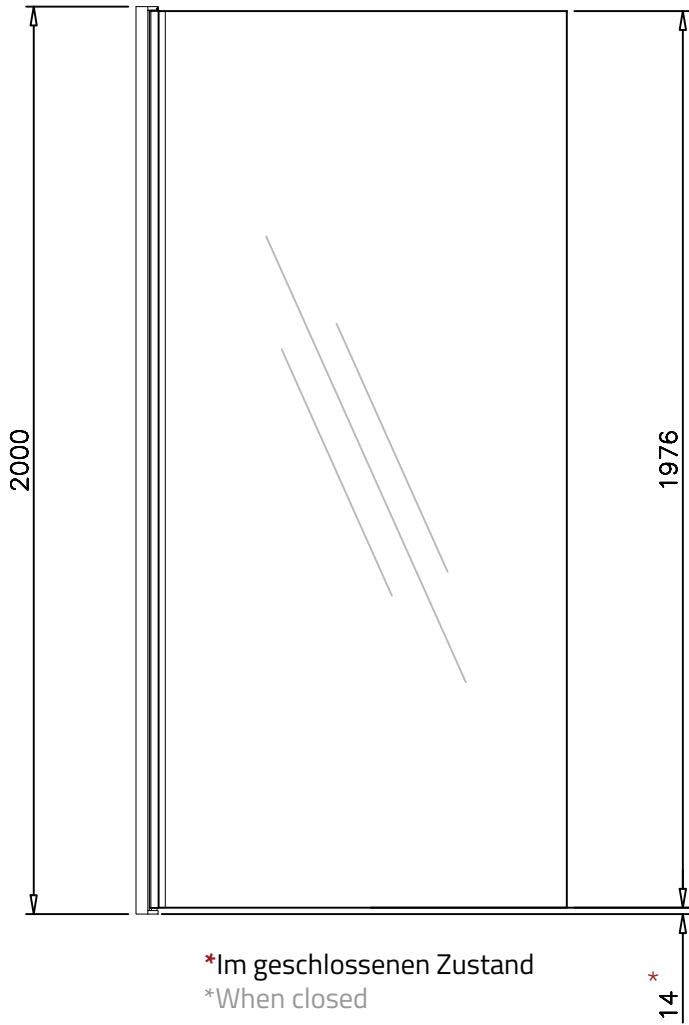

G-FITTINGS GmbH

Marie-Curie-Straße 16-18
 46446 Emmerich am Rhein
 T +49 (0)2822 962 0
 F +49 (0)2822 962 221
 E sales@g-fittings.com

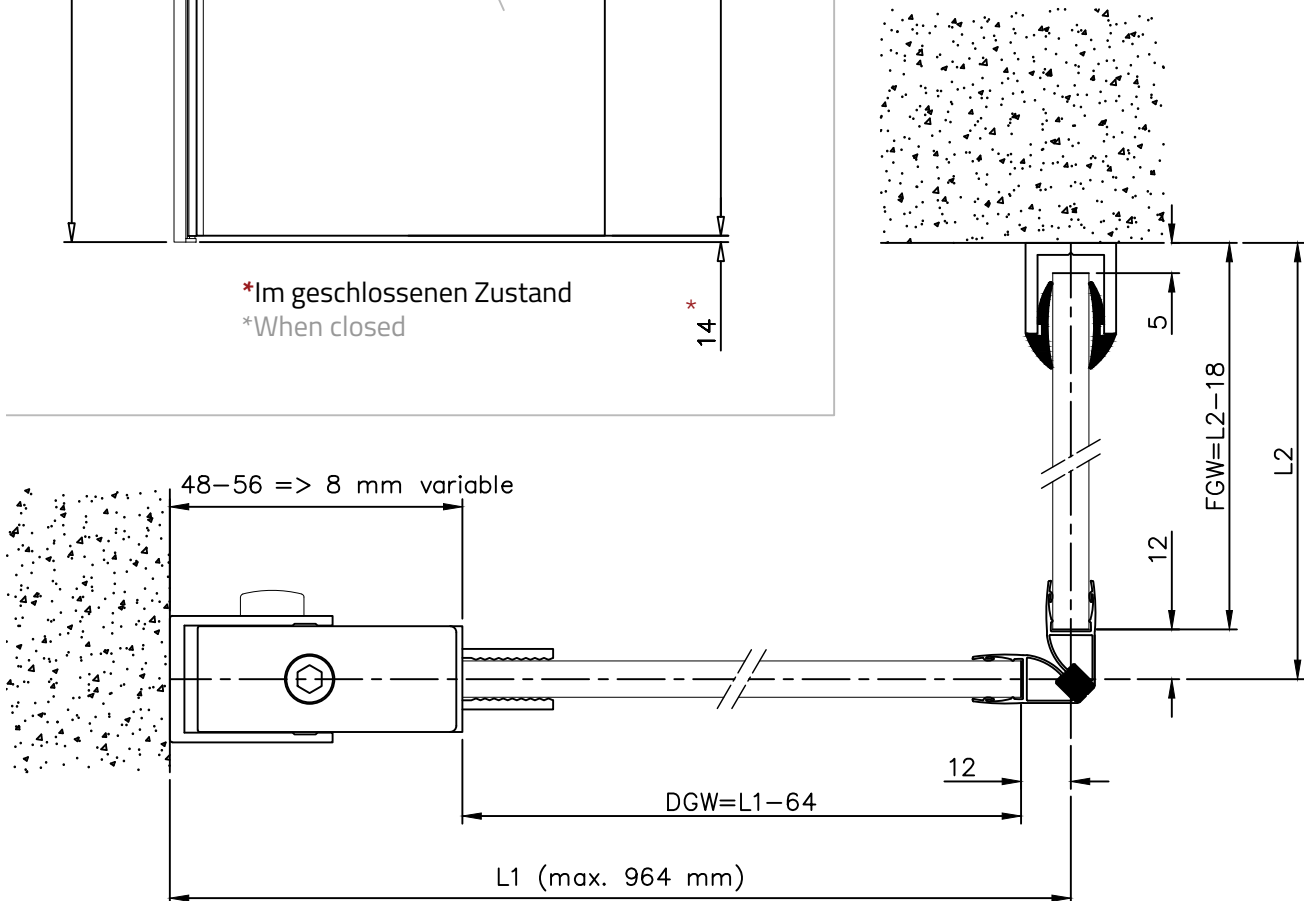

Art. 29.4016.002.10
Art. 29.4016.002.26
Art. 29.4016.002.46

Stand 10.2021

1. Montage des Wandprofils:
1. Mounting of the wall profile:

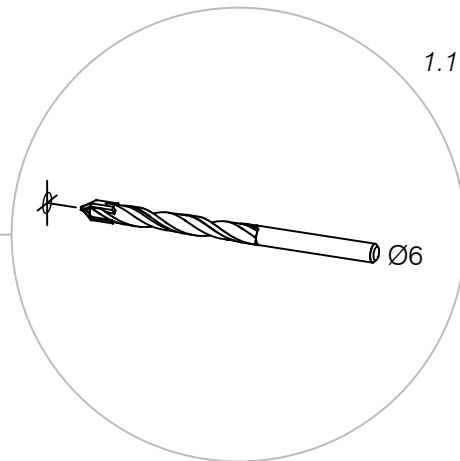
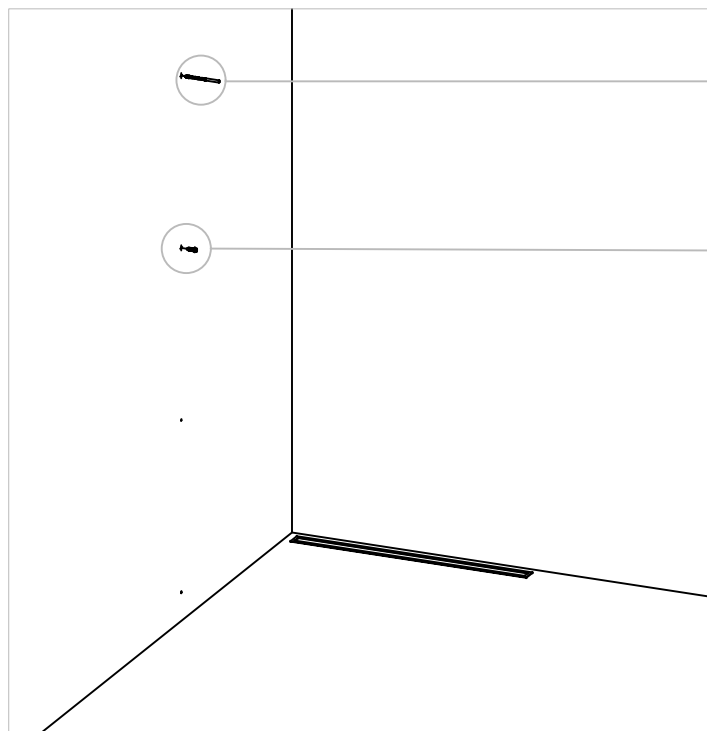

1.1

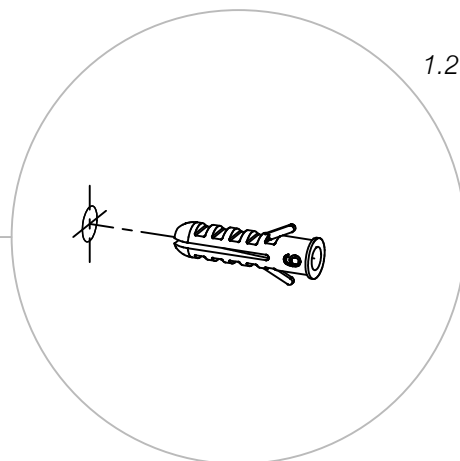

1.2

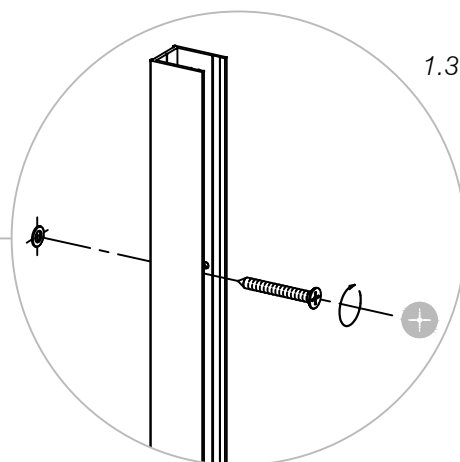
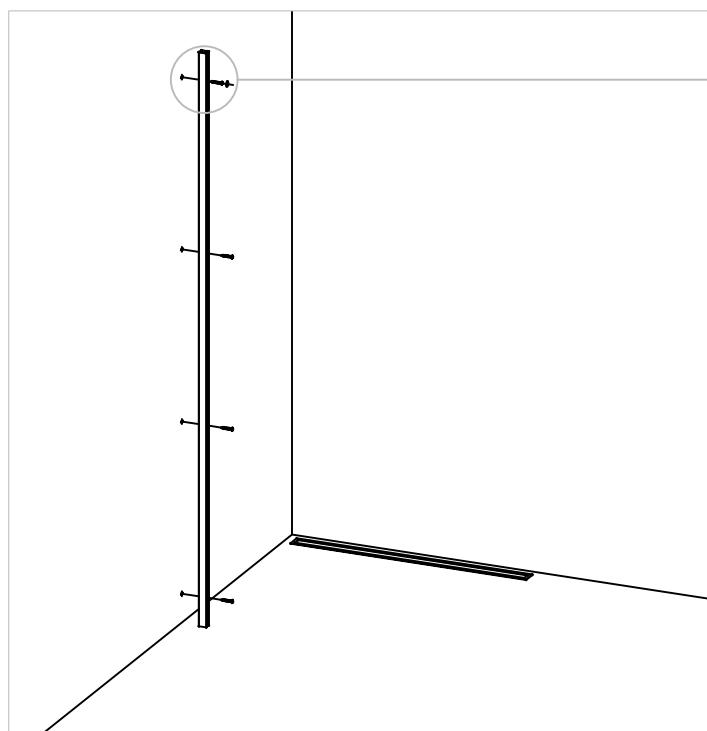

1.3

Art. 29.4016.002.10
Art. 29.4016.002.26
Art. 29.4016.002.46

Stand: 10.2021

2. Montage des Türprofils an die Türscheibe:
2. Mounting the door profile to the door glass:

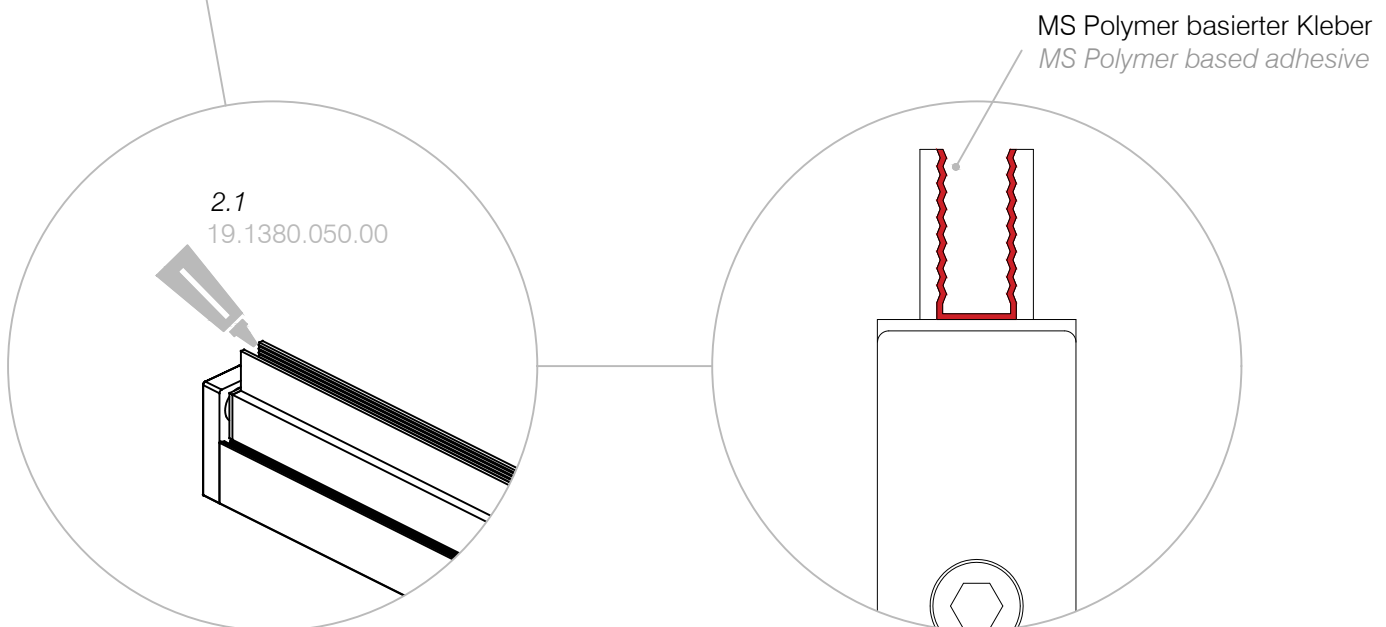
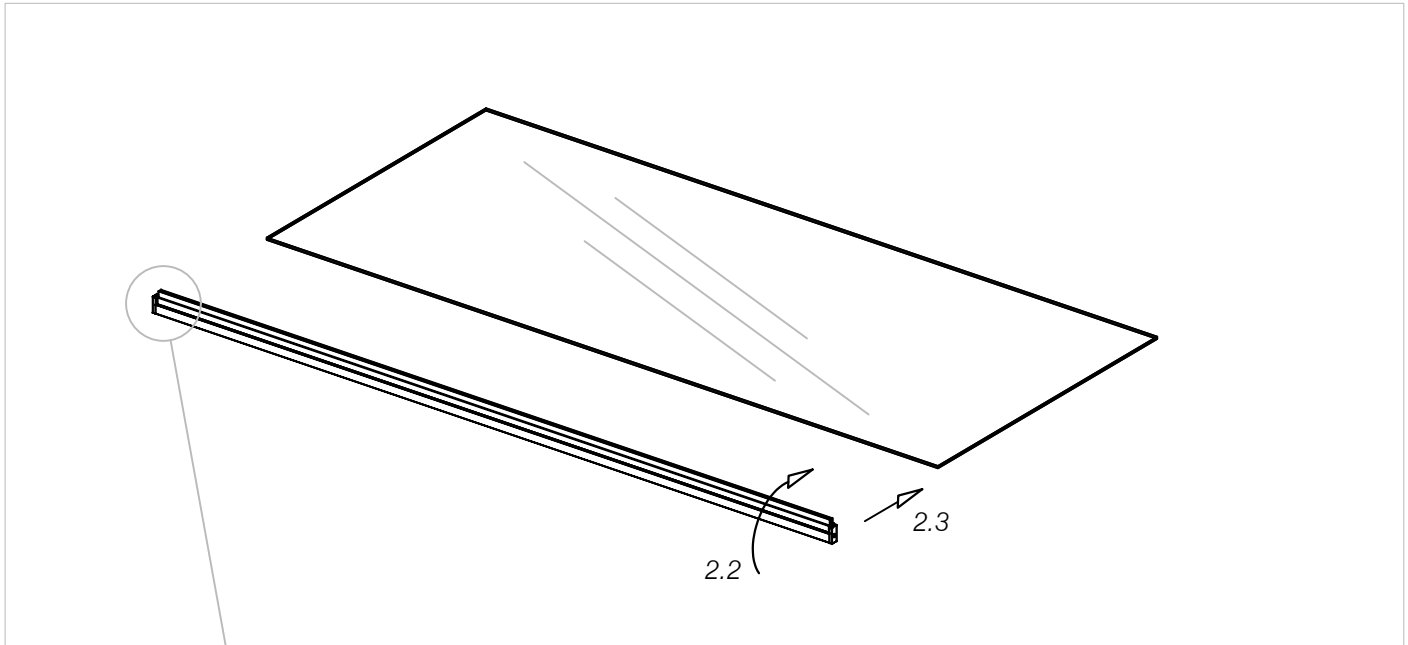

Wichtig: Vor der Montage das Glas im Bereich der Klebefläche reinigen.
Wir empfehlen G-Fittings Glasreiniger art. 91.1800.000.00

Important: Before mounting, clean the glass in the area of the bonding surface.
We recommend G-Fittings glass cleaner art. 91.1800.000.00

Art. 29.4016.002.10
 Art. 29.4016.002.26
 Art. 29.4016.002.46

3. Montage der Glastüre:
 3. Mounting the glass door:

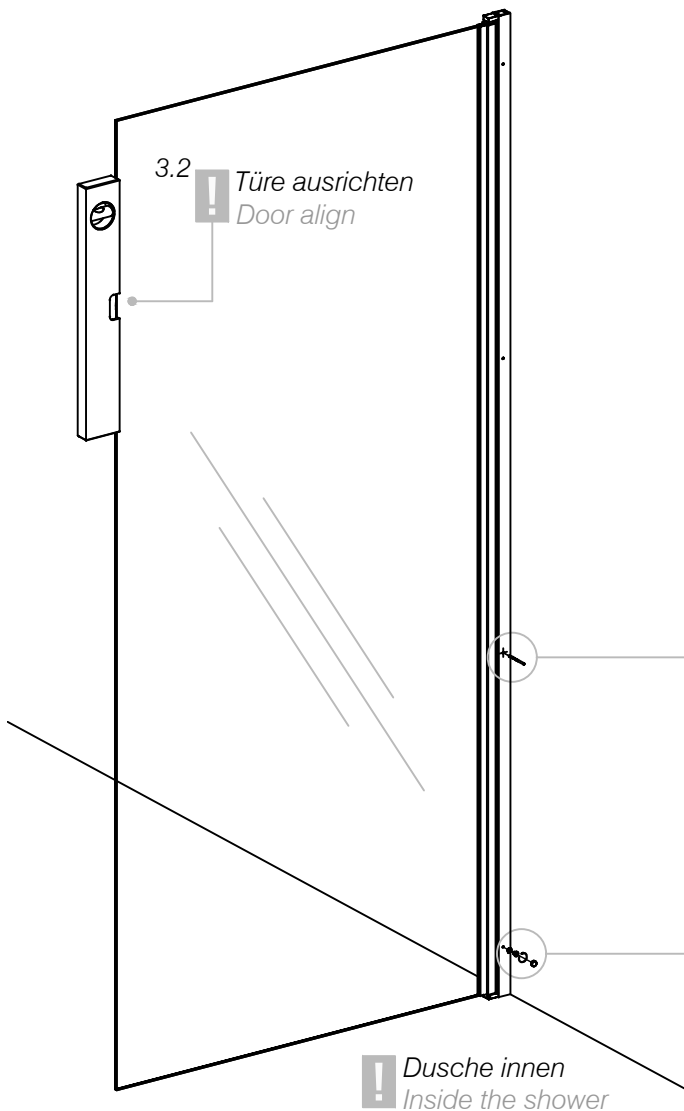
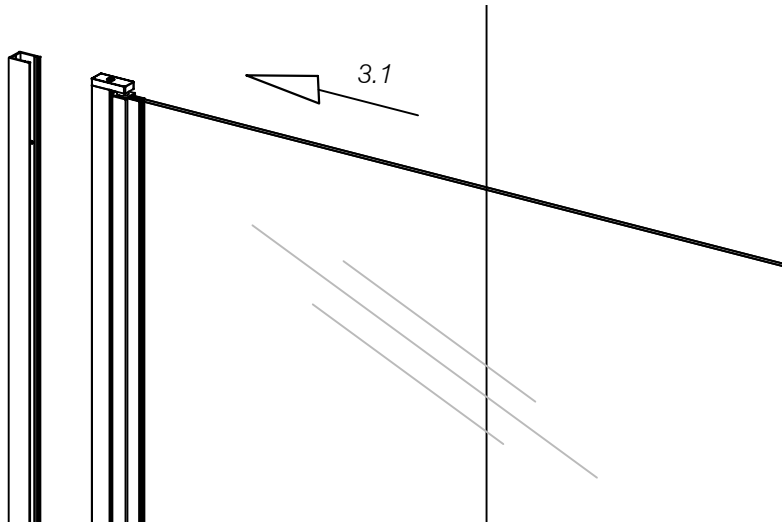

- 3.3 **!** Bohrungen auf das Scharnierprofil übertragen & zusammenschrauben.
- 3.4 Drill holes transferred to the hinge profile and screw it together.

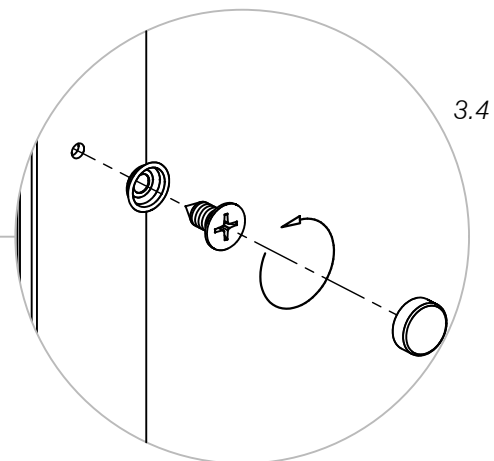
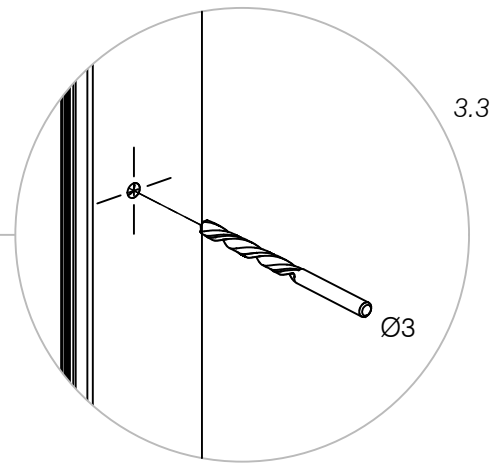

4. Einstellen der 0° Stellung der Türe:

4. Setting the 0° position of the door:

Draufsicht
 Top view

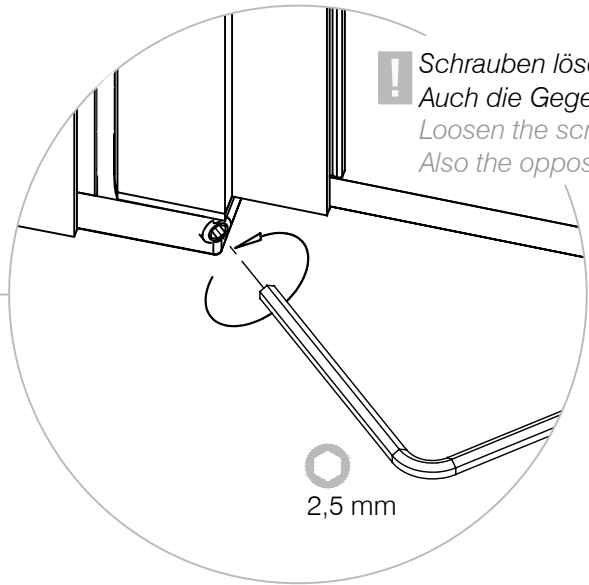
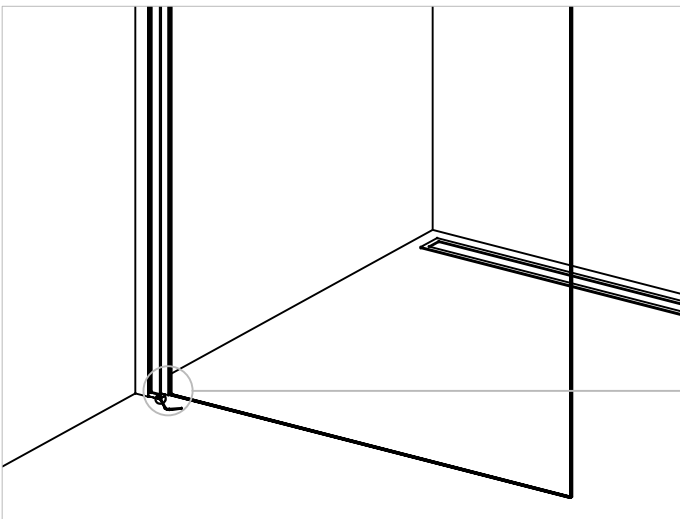
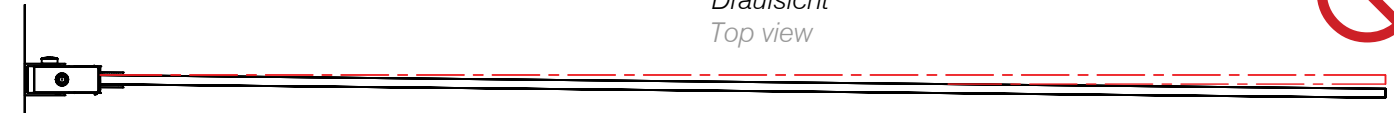

! Schrauben lösen.
 Auch die Gegenseite
 Loosen the screws.
 Also the opposite side

2,5 mm

Draufsicht
 Top view

! Ausrichten
 Adjust

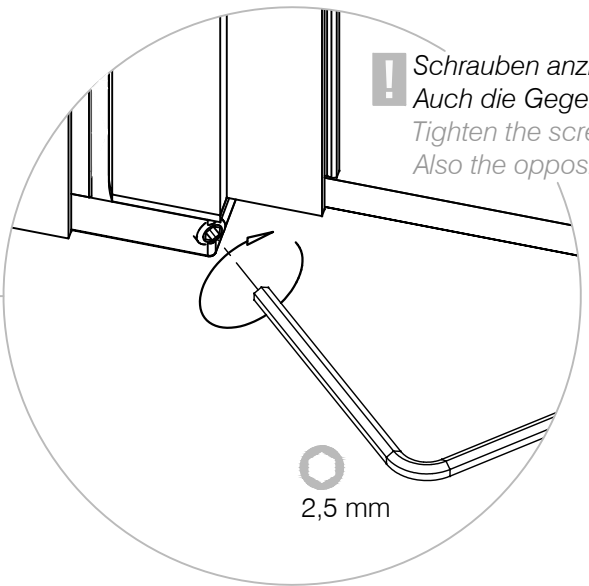
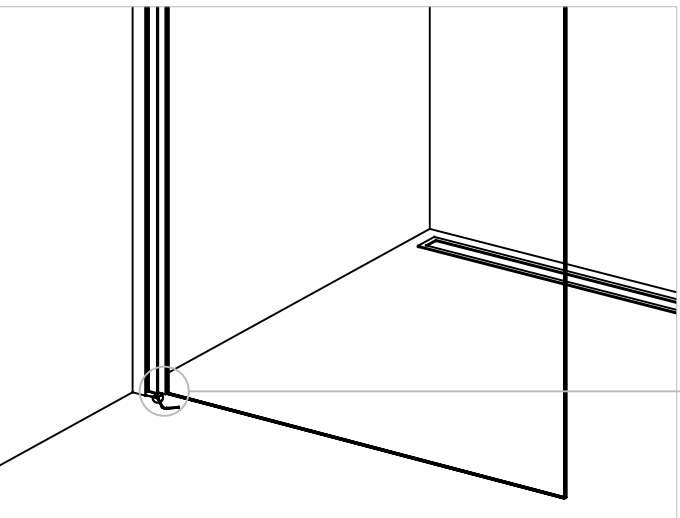



! Schrauben anziehen.
 Auch die Gegenseite
 Tighten the screws.
 Also the opposite side

2,5 mm

5. Profile für Festglas montieren:

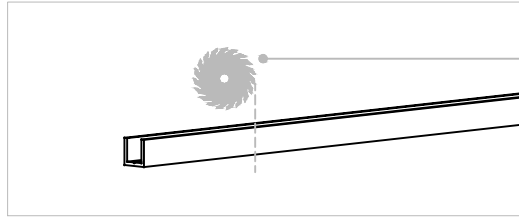
5. Mount the profiles for fixed glass:



5.1  *Schneiden Sie die Profile auf gewünschte Längen*
Cut the profiles to desired lengths

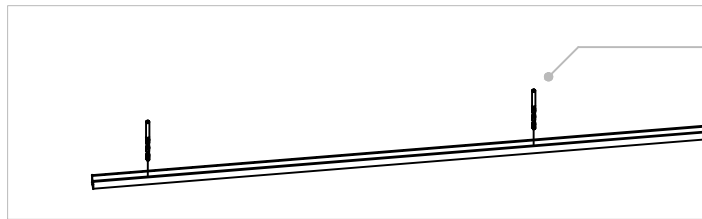

5.2  *Vorbohren der Profile*
Pre-drill the profiles

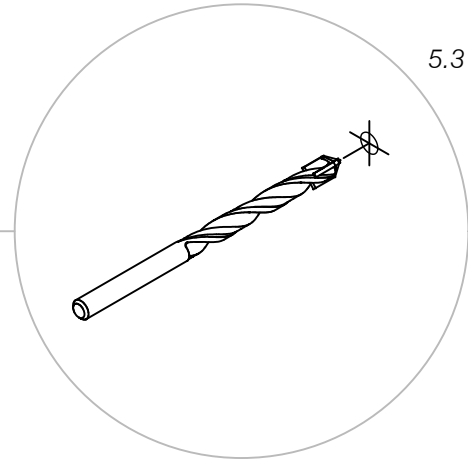
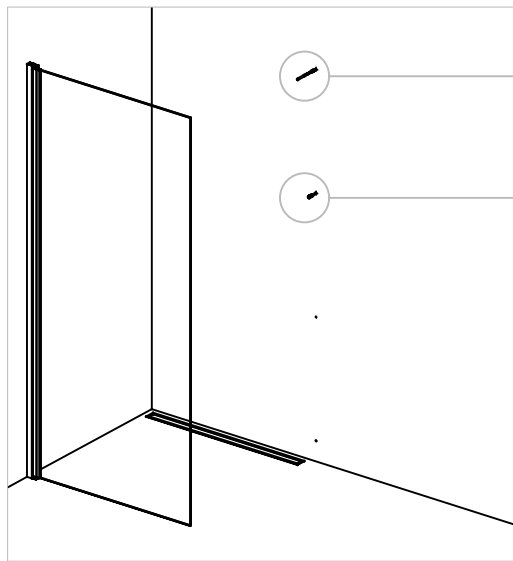

5.3

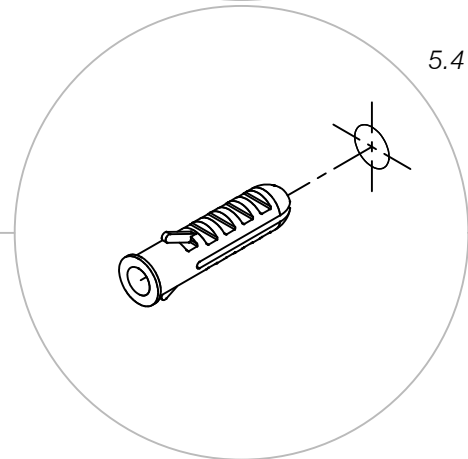

5.4

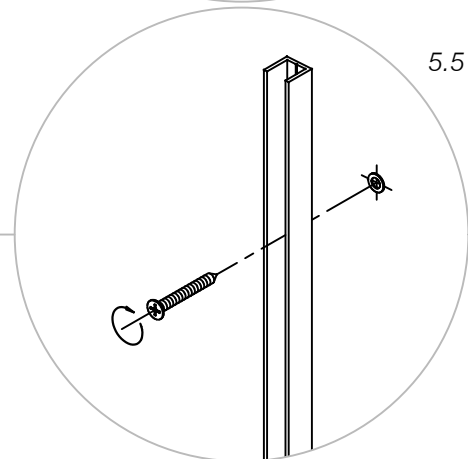
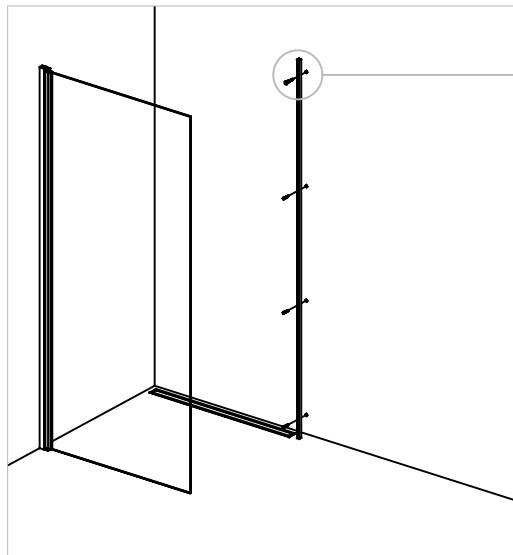

5.5

Art. 29.4016.002.10
 Art. 29.4016.002.26
 Art. 29.4016.002.46

! Wir empfehlen Ihnen die Profile im Boden einzulassen und ebenerdig installieren
 We recommend you to flush the profiles with the floor during the mounting

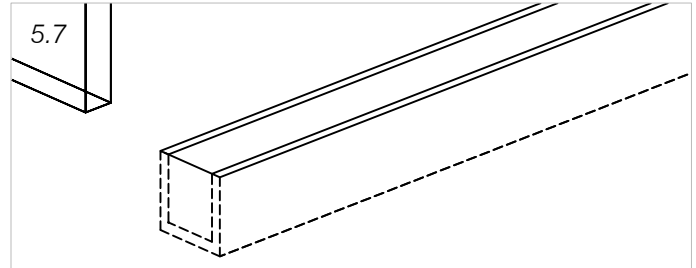
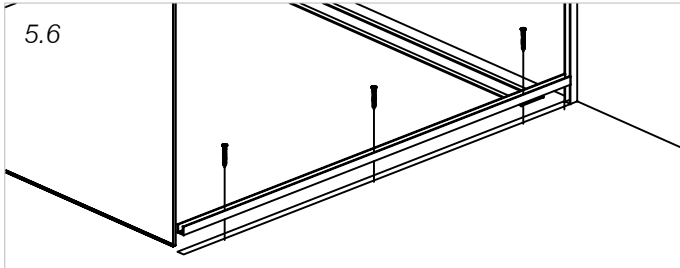

6. Festglas montieren:
 6. Mount the fix glass:

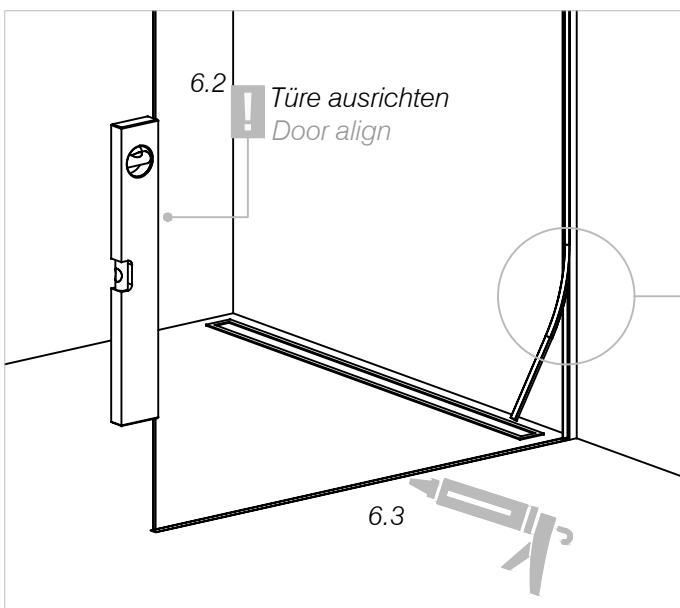
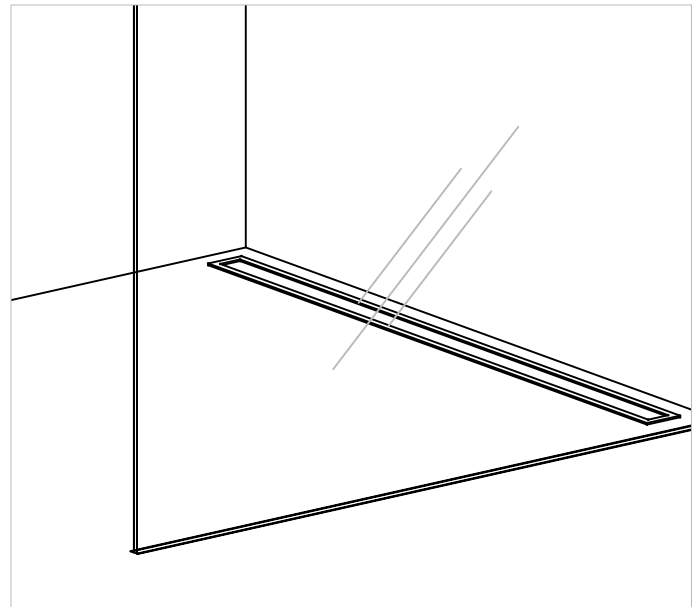
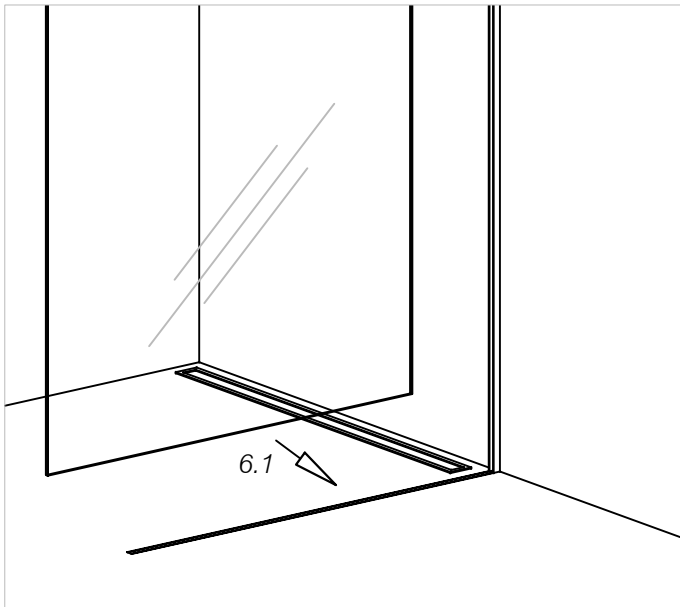

! Verglasungsdichtung montieren
 6.4 Mount glazing gasket

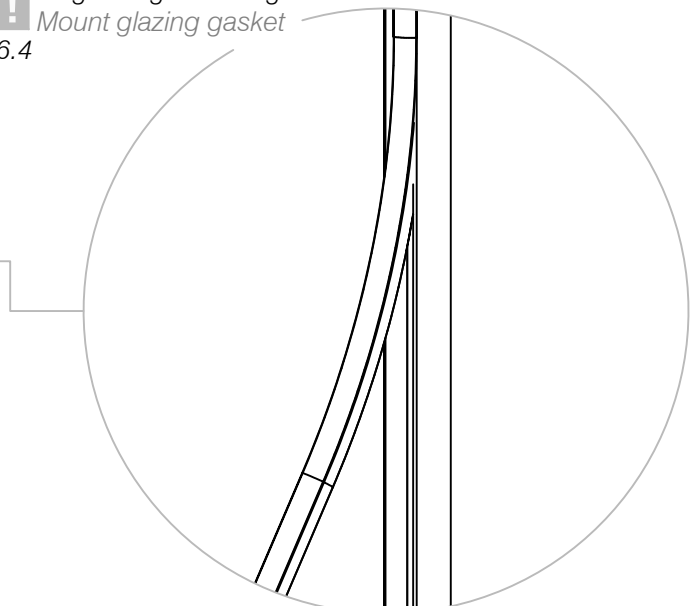

7. Stabilisierungsstangen montieren:
 7. Reinforcement bar installation:

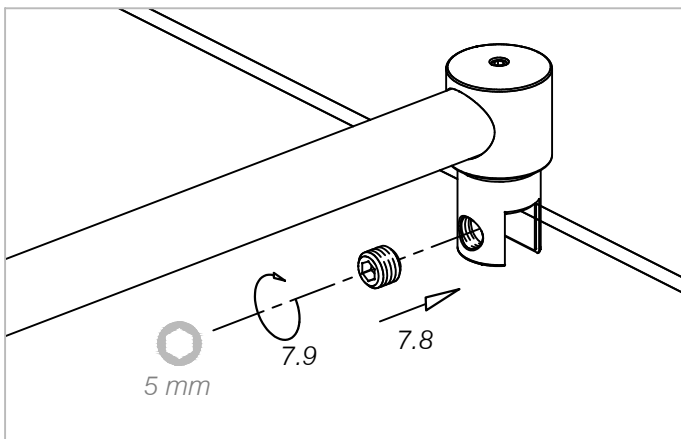
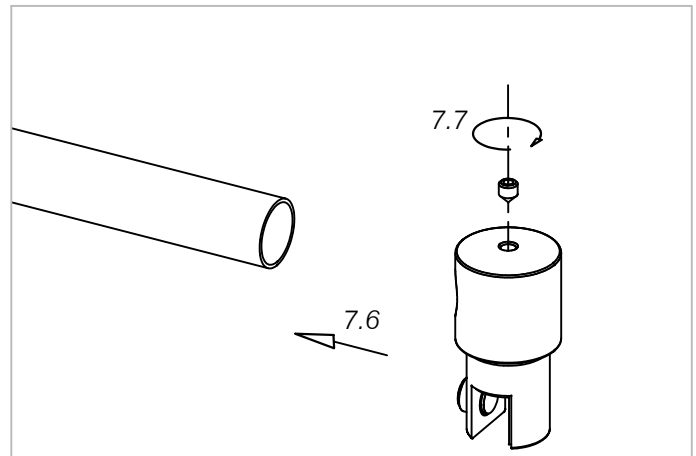
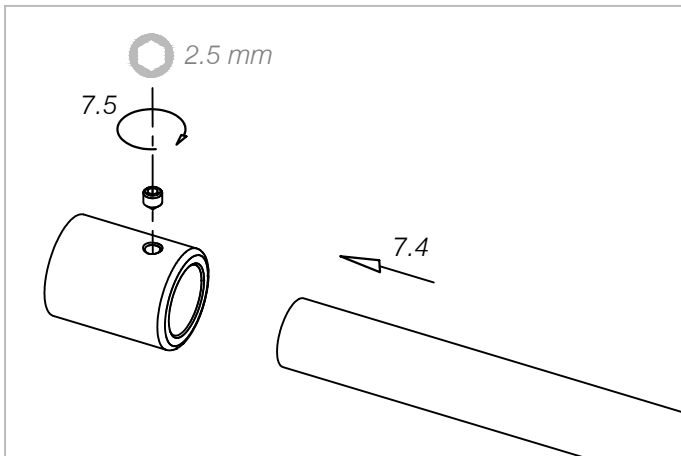
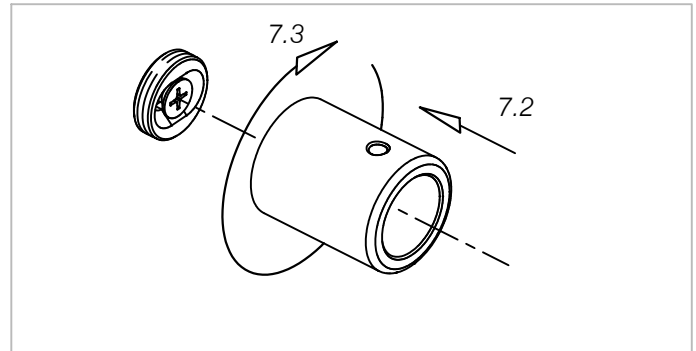
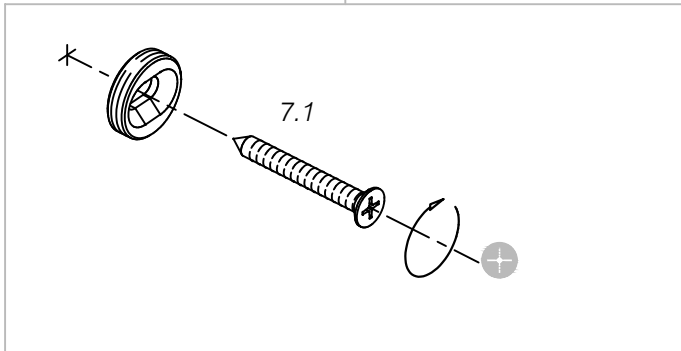
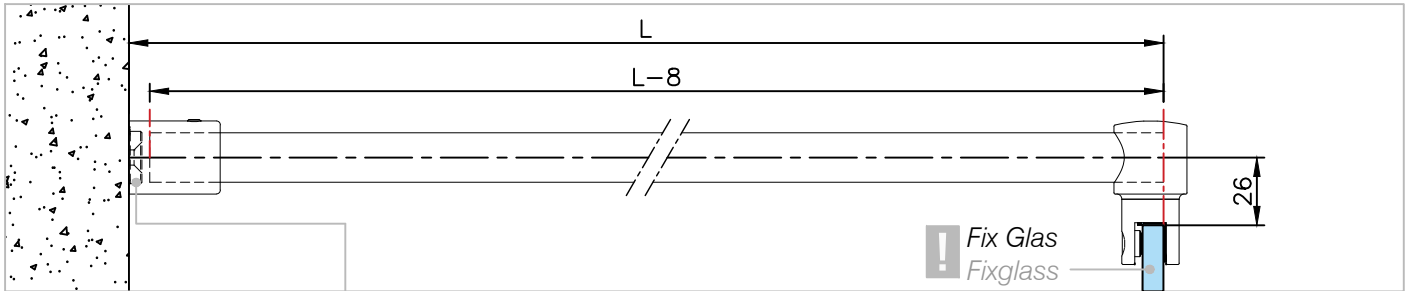

Art. 29.4016.002.10
Art. 29.4016.002.26
Art. 29.4016.002.46

Stand: 10.2021

8. Lippendichtungen anbringen:
8. Apply seals:

