

Technische Daten:
Oberteil Zapfenaufnahme - NIKA

Datasheet:
Top part pin Holder - NIKA

Art. 77450107000-12
Art. 77450107000-26

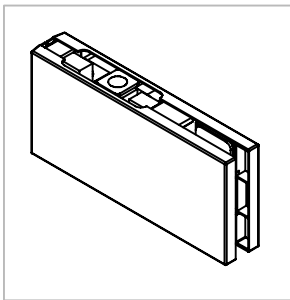

Ausführung:
Options:

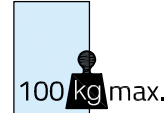
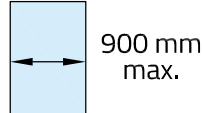
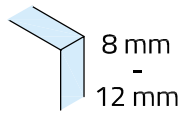

Material:	Aluminium	Gewicht: / Weight: 0,6 kg
Material:	Aluminium	
Oberflächen:	Edelstahl-Design	Anthrazit-Design
Finish:	Stainless steel design	Antracite design

Abmaße:
Dimensions:

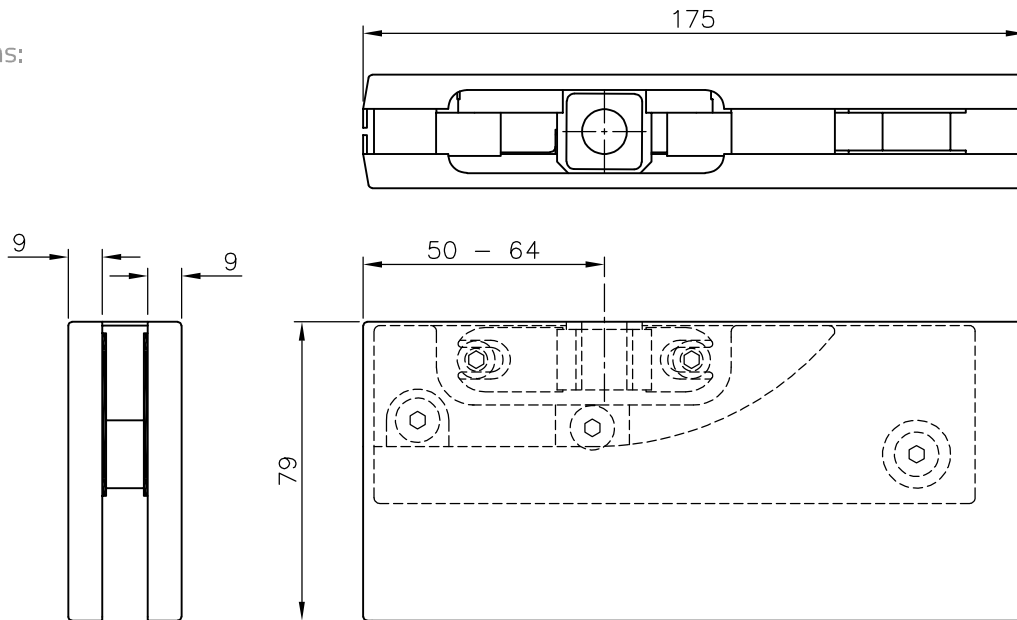

Glasausschnitt:
Glass cut out:

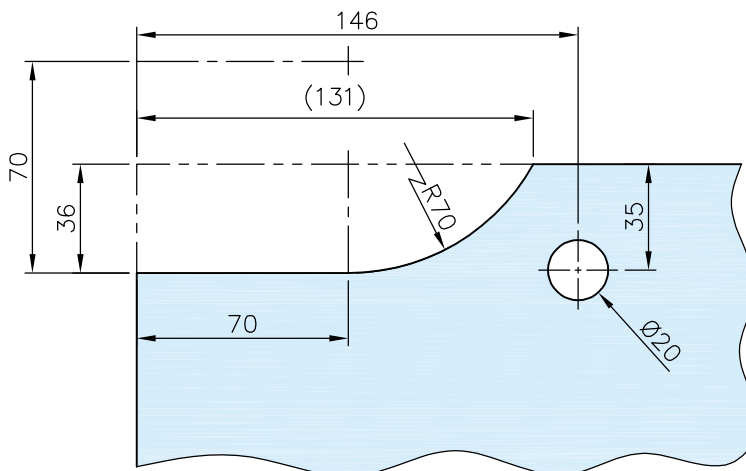

Glasbearbeitung:
Glass preparation:

Hier abgebildet: Oberer Zapfen MIRVET- Art. 77450108000-xx
Shown here: Top pin MIRVET - Art. 77450108000-xx

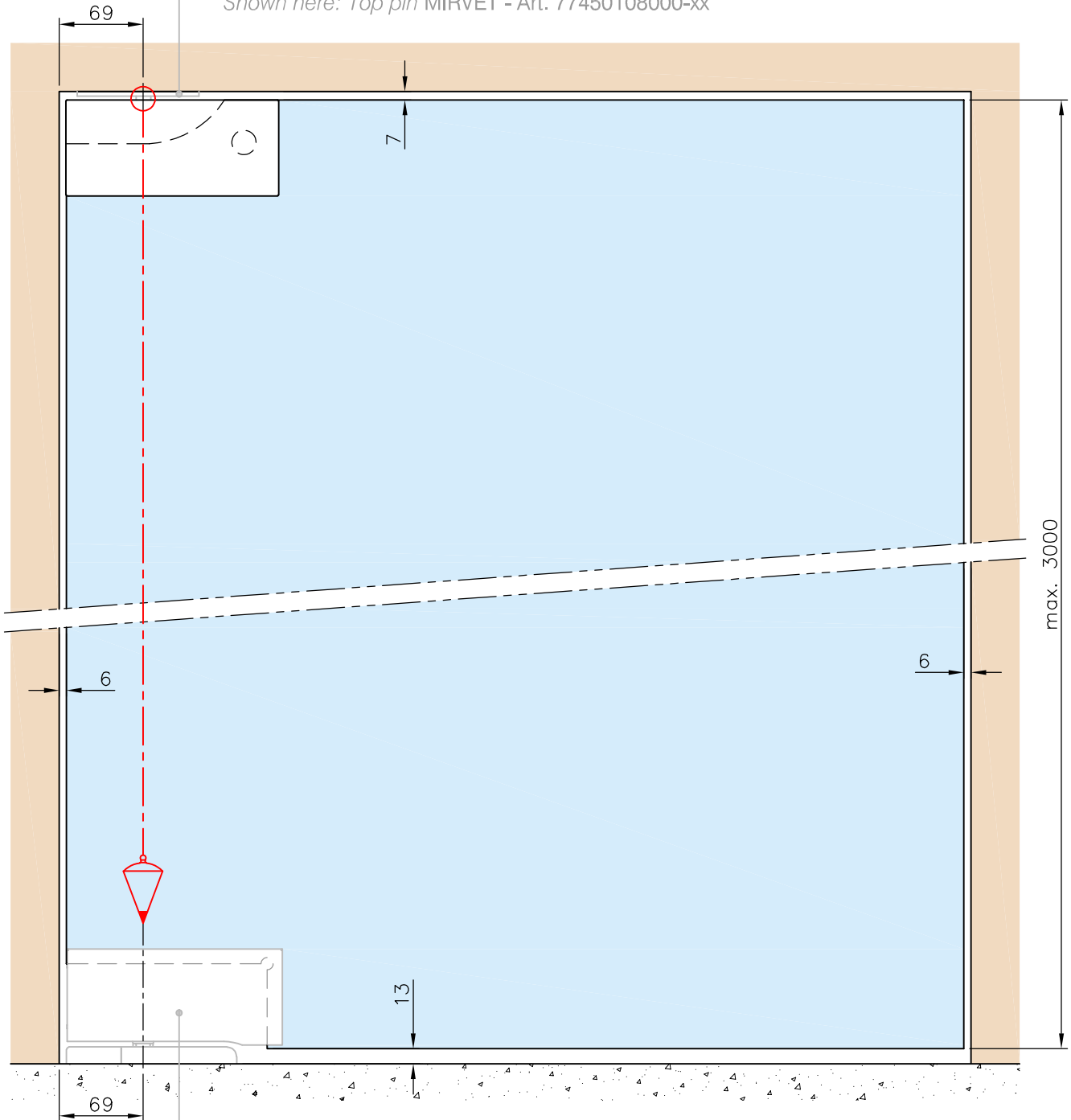

Hier abgebildet: Eckbeschlag hydraulisch LEVI - Art. 77450106000-xx
Shown here: Hydraulic patch fitting LEVI - Art. 77450106000-xx

Art. 77450107000-12
 Art. 77450107000-26

1. Eckbeschlag Glasmontage für:
 1. Patch fitting glass mounting for:

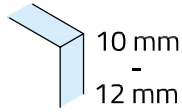

1.1

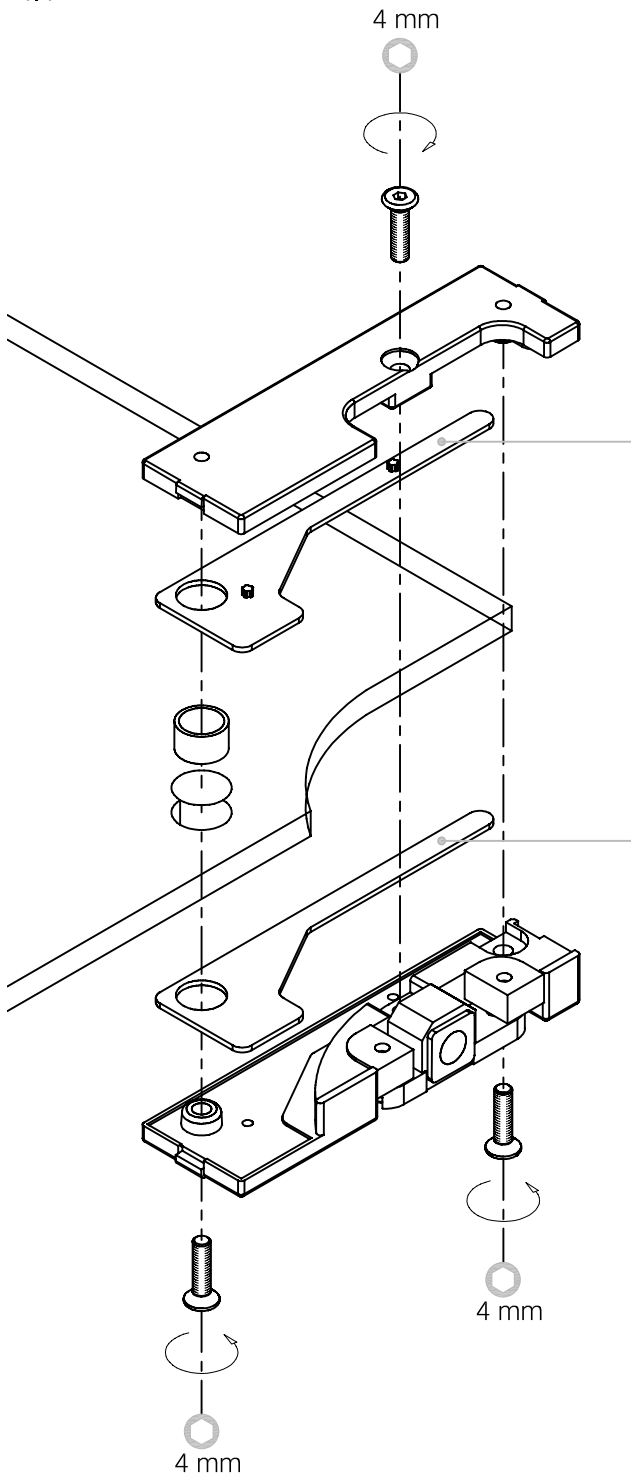

Wichtig: Vor der Montage das Glas im Bereich der Klebefläche reinigen.
 Wir empfehlen **G-Fittings** Glasreiniger art. **779118000000**

Important: Before mounting, clean the glass in the area of the bonding surface.
 We recommend **G-Fittings** glass cleaner art. **779118000000**

! Eine Gummieinlage je Glasseite.
 One rubber insert per glass side

1.2

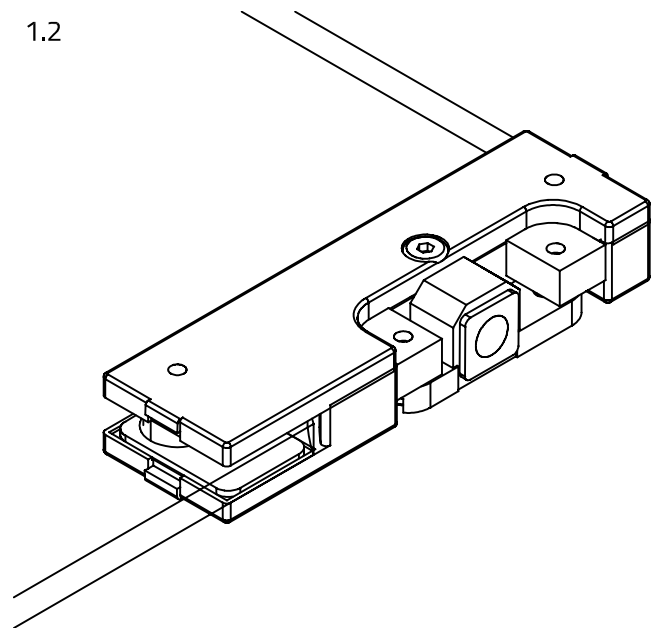

Art. 77450107000-12
Art. 77450107000-26

1. Eckbeschlag Glasmontage für:
1. Patch fitting glass mounting for:

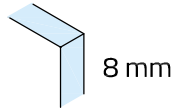

1.1

4 mm

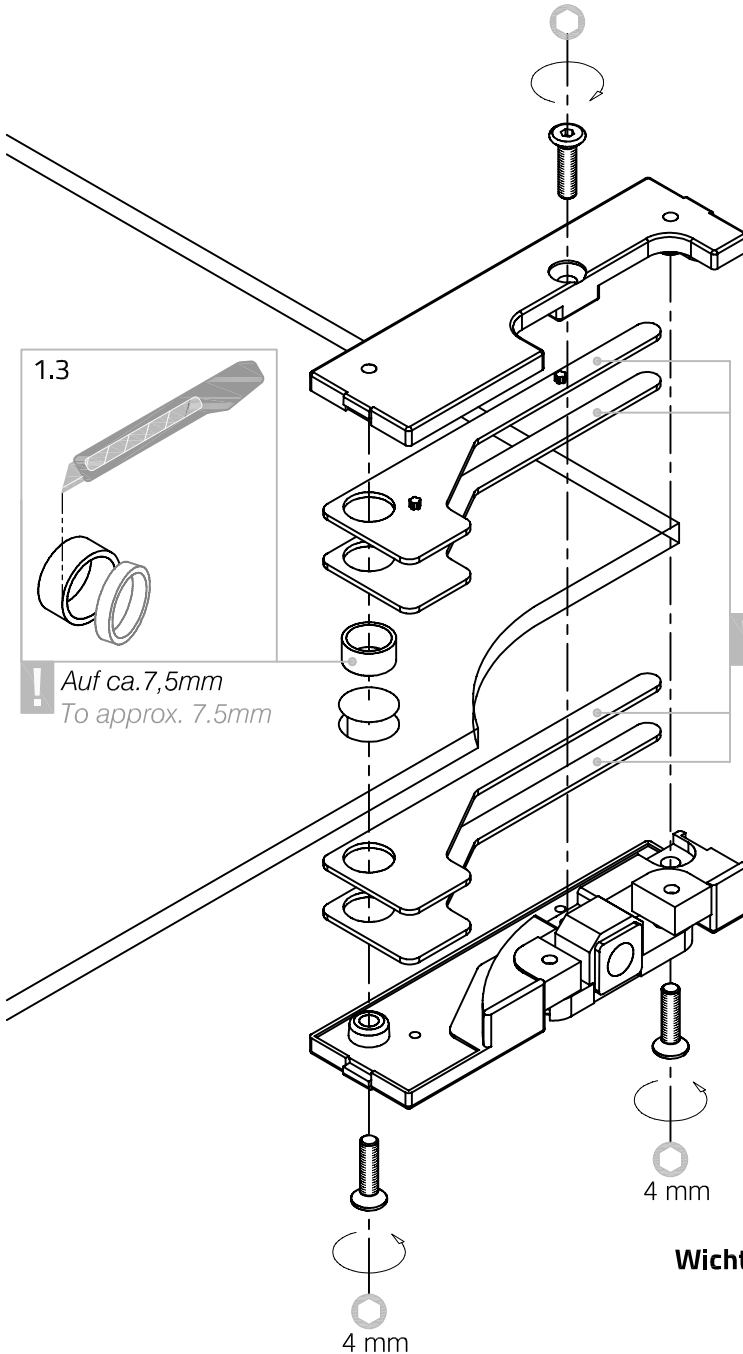

1.3

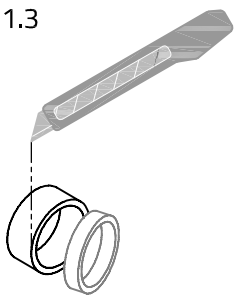

! Auf ca. 7,5mm
To approx. 7.5mm

1.2

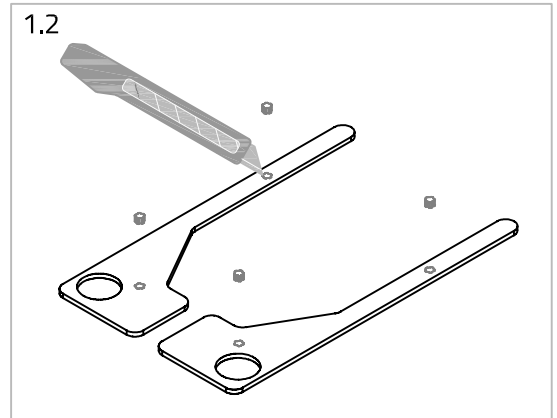

! Nur an den zusätzlichen Gummieinlagen entfernen.
Only remove at the additional rubber inserts.

! Zwei Gummieinlagen je Glasseite.
Two rubber inserts per glass side.

1.4

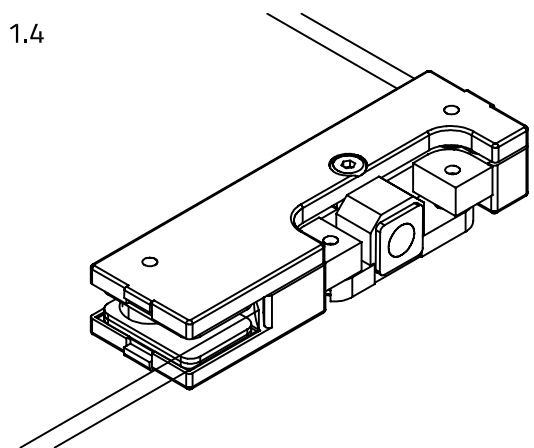

Wichtig: Vor der Montage das Glas im Bereich der Klebefläche reinigen.
Wir empfehlen **G-Fittings** Glasreiniger art. **779118000000**

Important: Before mounting, clean the glass in the area of the bonding surface.
We recommend **G-Fittings** glass cleaner art. **779118000000**

2. Tür Montage
2. Door mounting

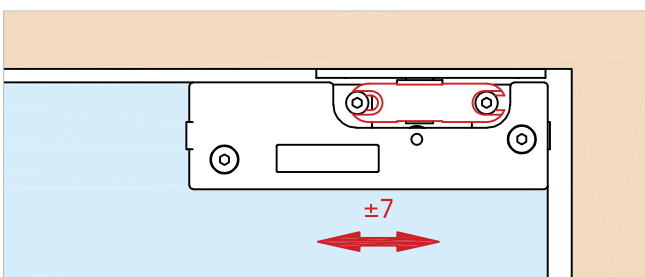
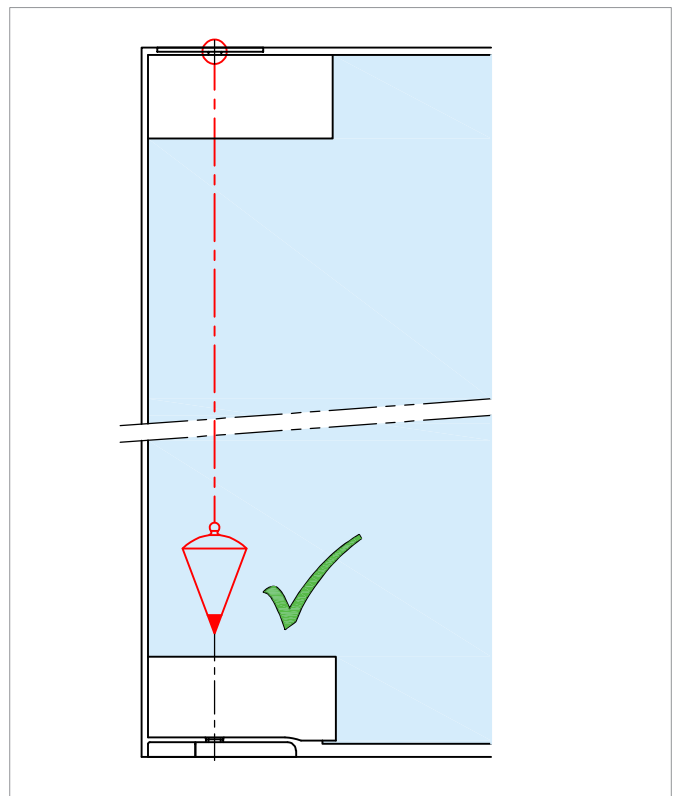
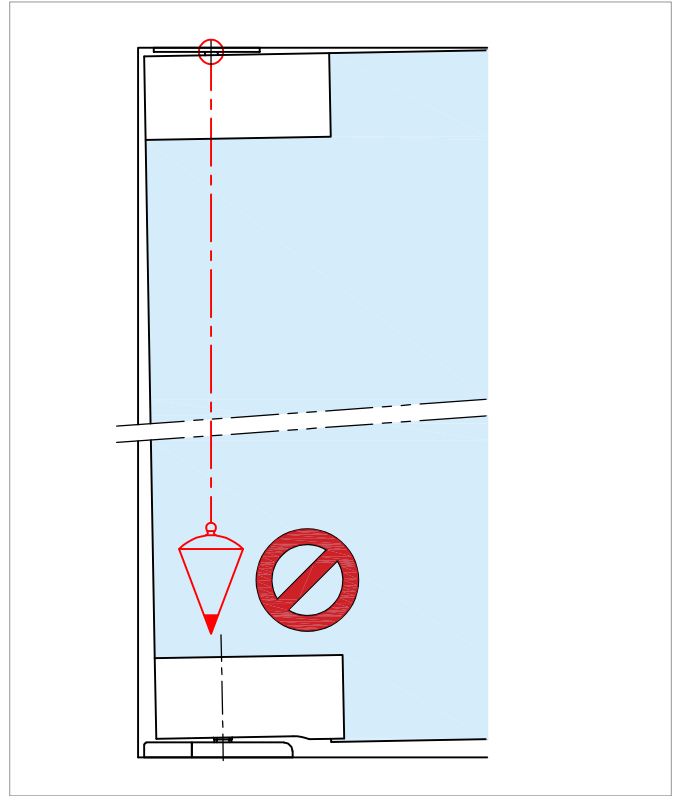
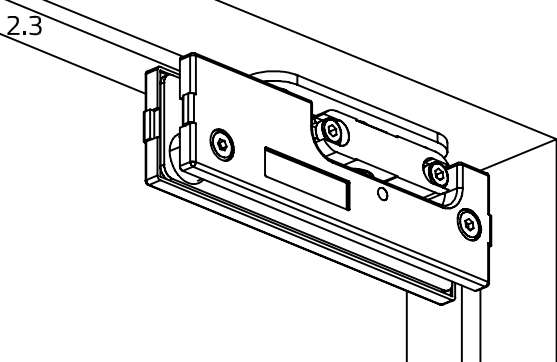
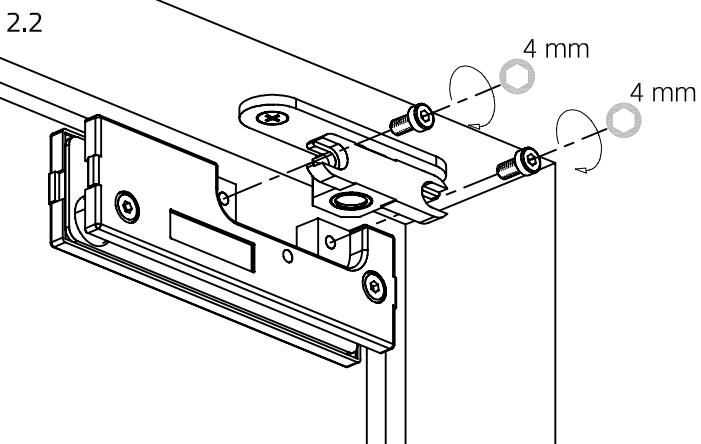
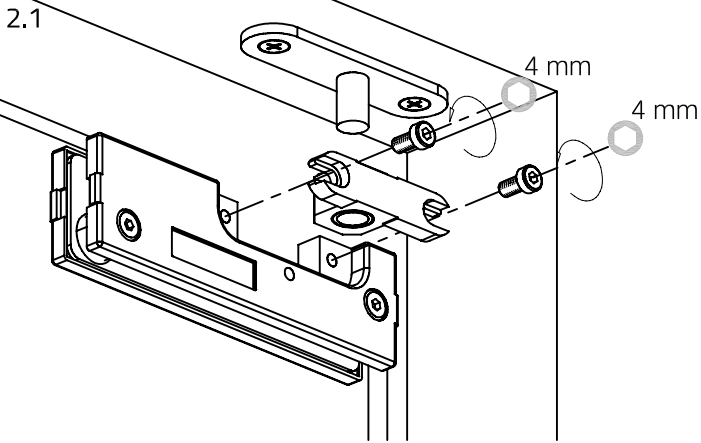

3. Abdeckkappen anbringen
3. Attach cover caps

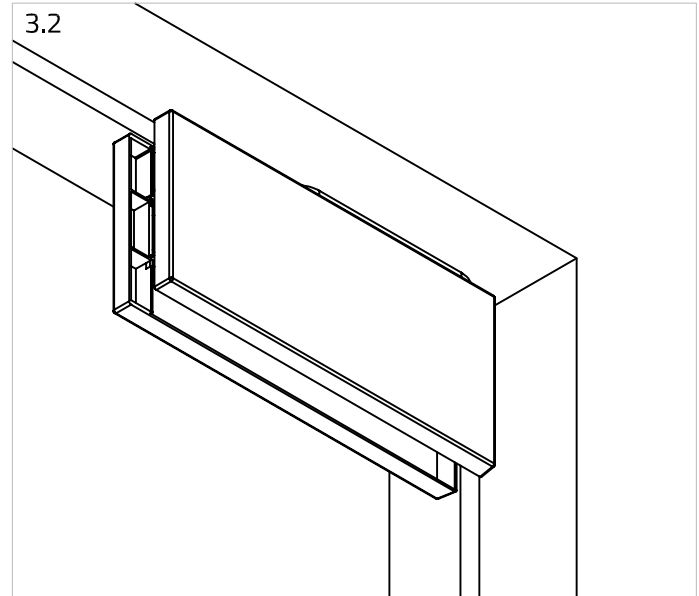
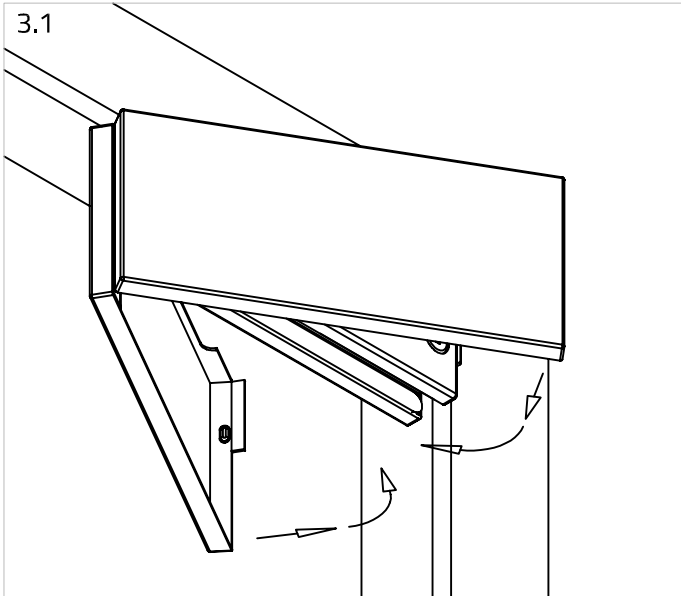

G-FITTINGS GmbH

Marie-Curie-Straße 16-18
46446 Emmerich am Rhein
T +49 (0)2822 962 0
E sales@g-fittings.com