

Technische Daten:
Bodenfeder - LARISSA

Datasheet:
Floor spring - LARISSA

Art. 77450101000-12
Art. 77450101000-26

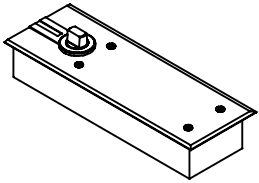

Ausführung:
Options:

EN1154

3	8	2	4	1	1	3
---	---	---	---	---	---	---

 200 kg max.

Material: V2A
Material: Stainless steel AISI 304

Gewicht: / Weight: 5,0 kg

Oberflächen: Edelstahl-Design
Finish: Stainless steel design

Anthrazit-Design
Anthracite design

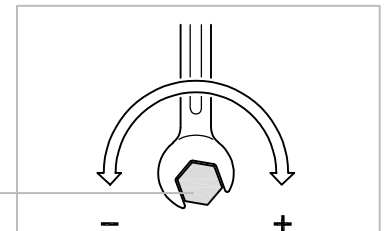
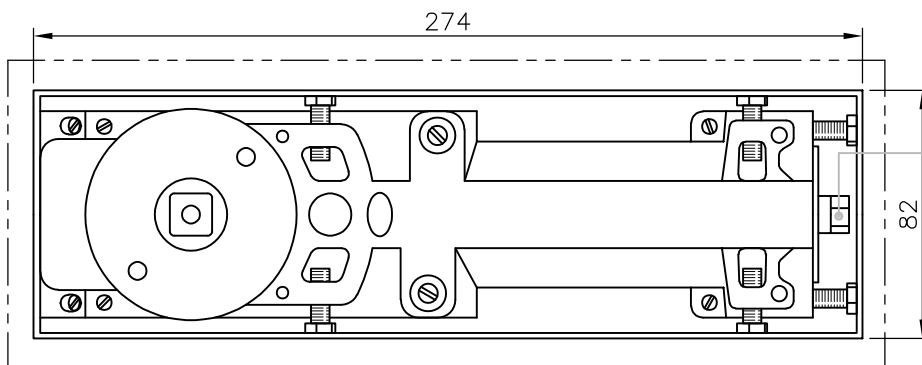
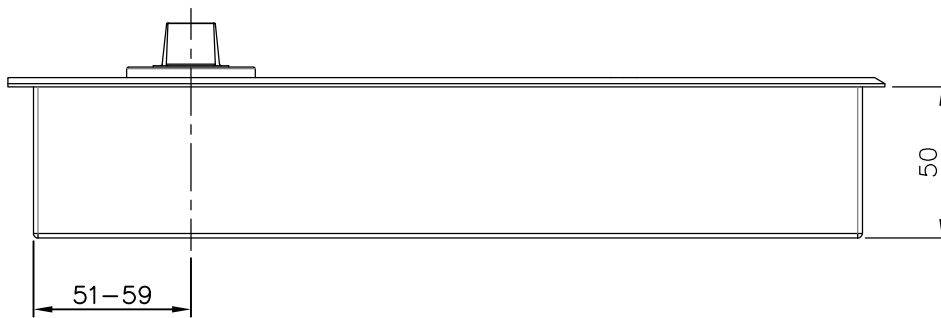
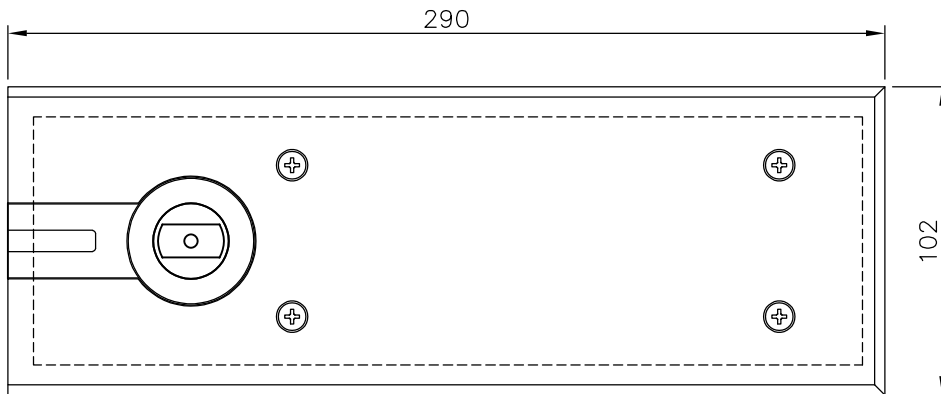

Kraft: Power:	Umdrehungen: Turns:	Richtung: Direction:
2	4	-
3	0	*
4	7	+

* : Werkseitige Voreinstellung = 3
: Factory pre-set force = 3

Art. 77450101000-12
Art. 77450101000-26

Geschwindigkeitseinstellung:
Speed adjustment:

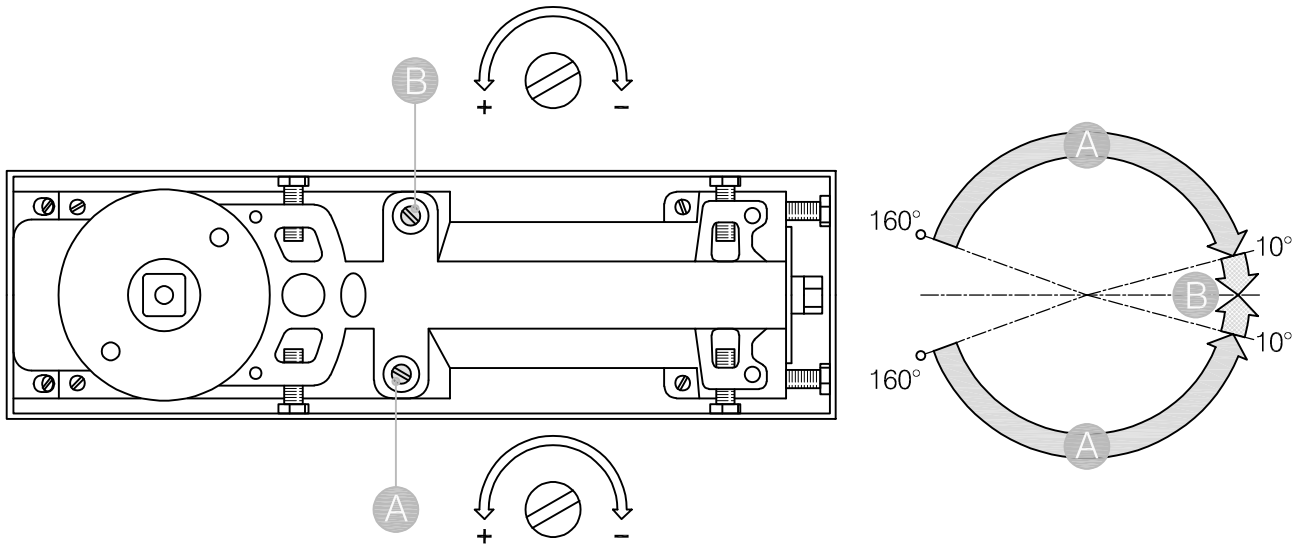

Einstellungen:

Zwei unabhängige Ventile zur Einstellung der Schließgeschwindigkeiten in zwei Bereichen.
Ventil A - Schließgeschwindigkeit von 160° - 10°
Ventil B - Schließgeschwindigkeit von 10° - 0°

Für die Einstellung der Schließkraft über den gesamten Schließweg von 160° - 0° sehen sie bitte Seite 1

Settings:

Two independent valves for adjusting the closing speeds in two ranges.
Valve A - closing speed from 160° - 10°
Valve B - closing speed from 10° - 0°

For the adjustment of the closing force over the entire closing distance of 160° - 0° please see page 1

G-FITTINGS GmbH

Marie-Curie-Straße 16-18
46446 Emmerich am Rhein
T +49 (0)2822 962 0
F +49 (0)2822 962 221
E sales@g-fittings.com