

## ASSEMBLY INSTRUCTIONS

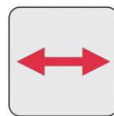

MAX  
90 KG



min. 550  
MAX 1100



MAX  
3000



7  
7+7



10 - 10,76  
12 - 12,76 mm

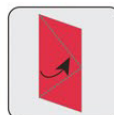

Required tool

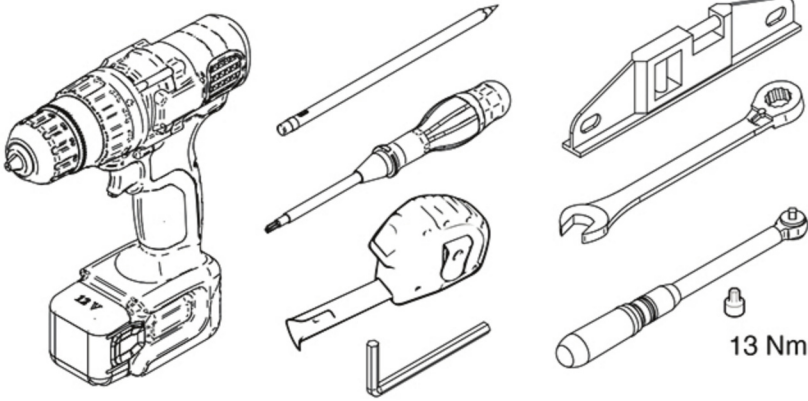

Clean the glass and profile before installing

We recommend our Glass cleaner Hendrika 7791180100000

Components

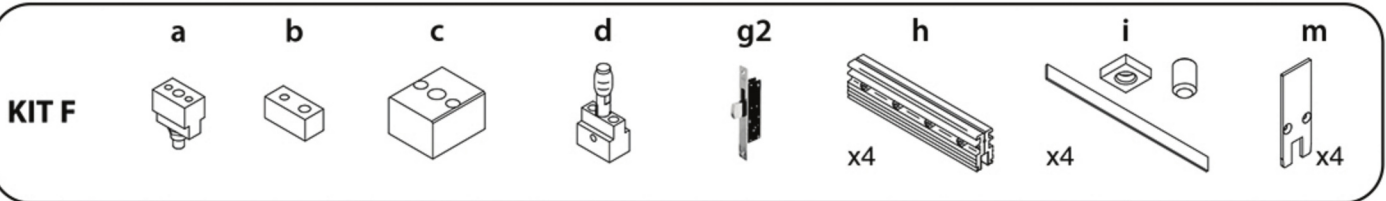
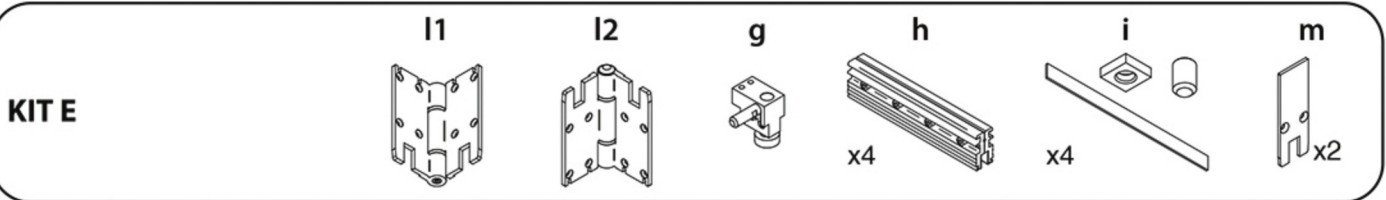
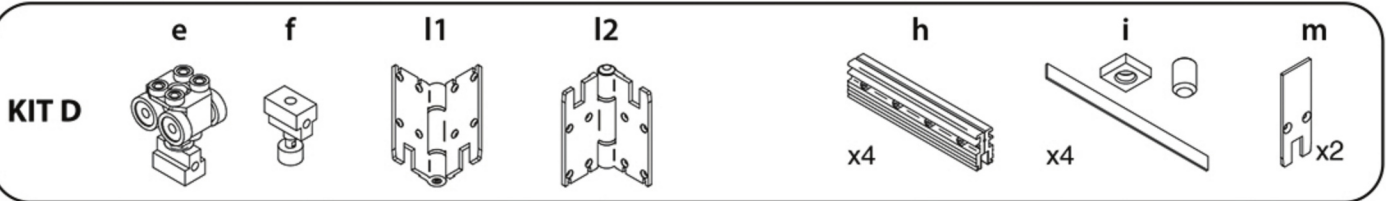
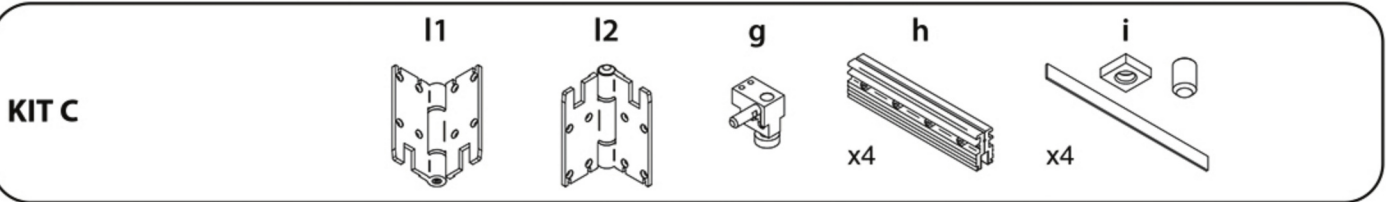
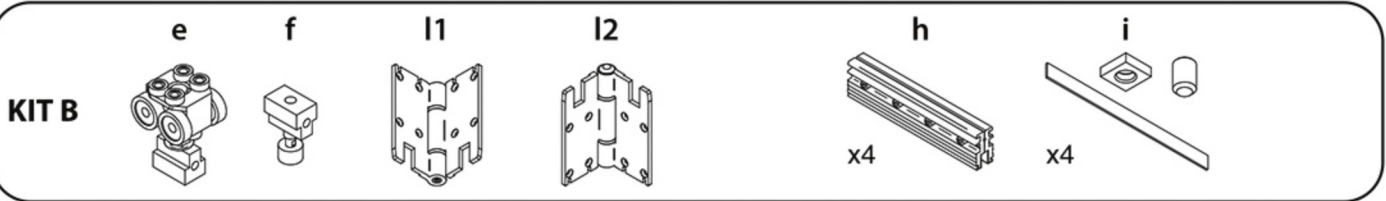
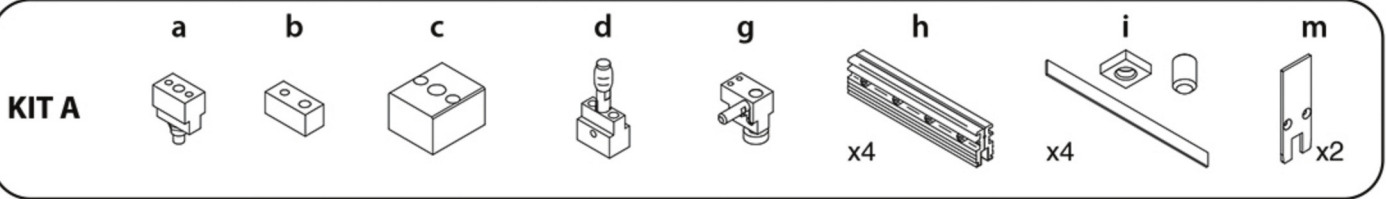

PROFILES

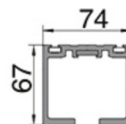

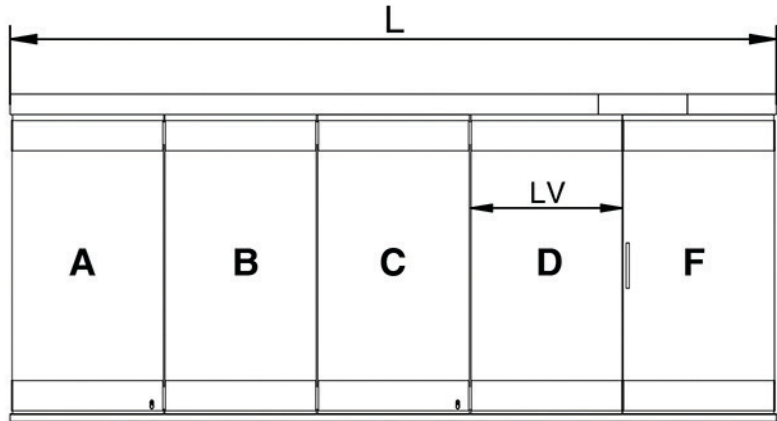
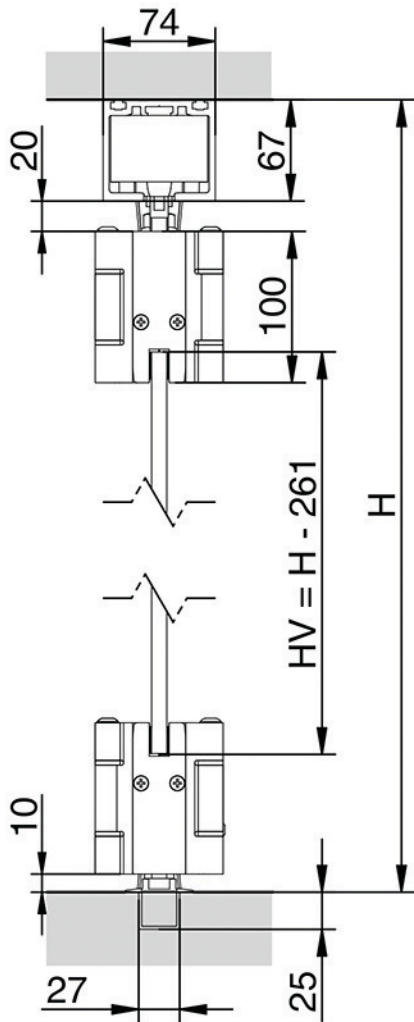

$$LV = \frac{L - (6 \times N) - 6}{N}$$

N = number of panels

**PROFILES**

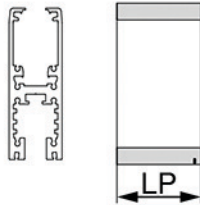

LP=LV-3

Configurations 2 - 4 - 6 panels

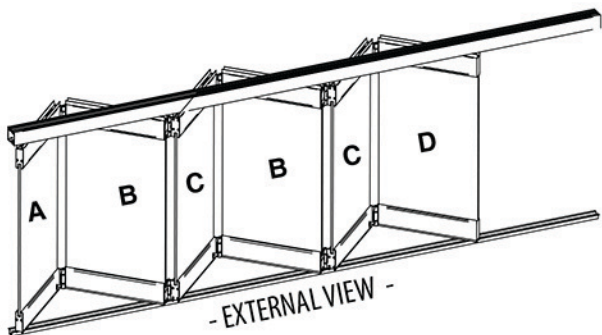

Configurations 3 - 5 - 7 panels

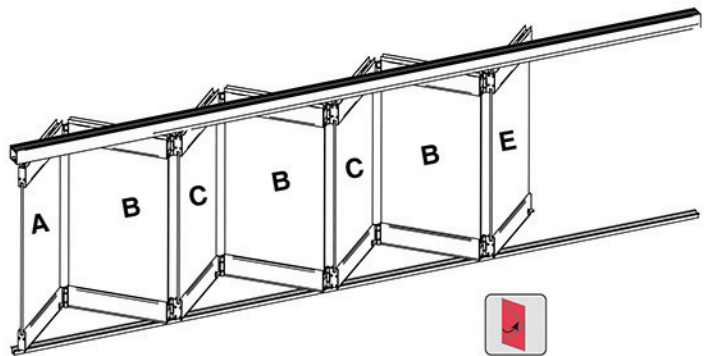

Configurations with independent swing door

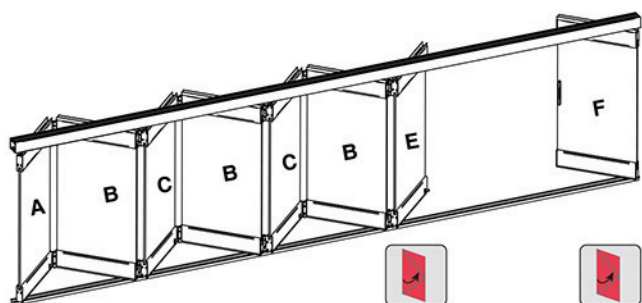
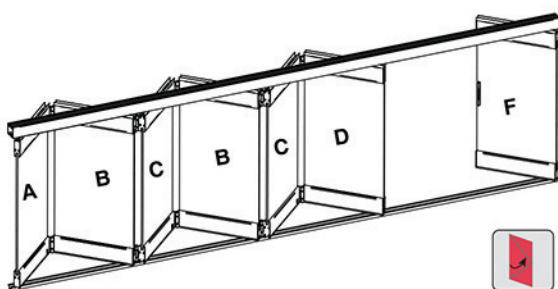

# 1a Profile assembly

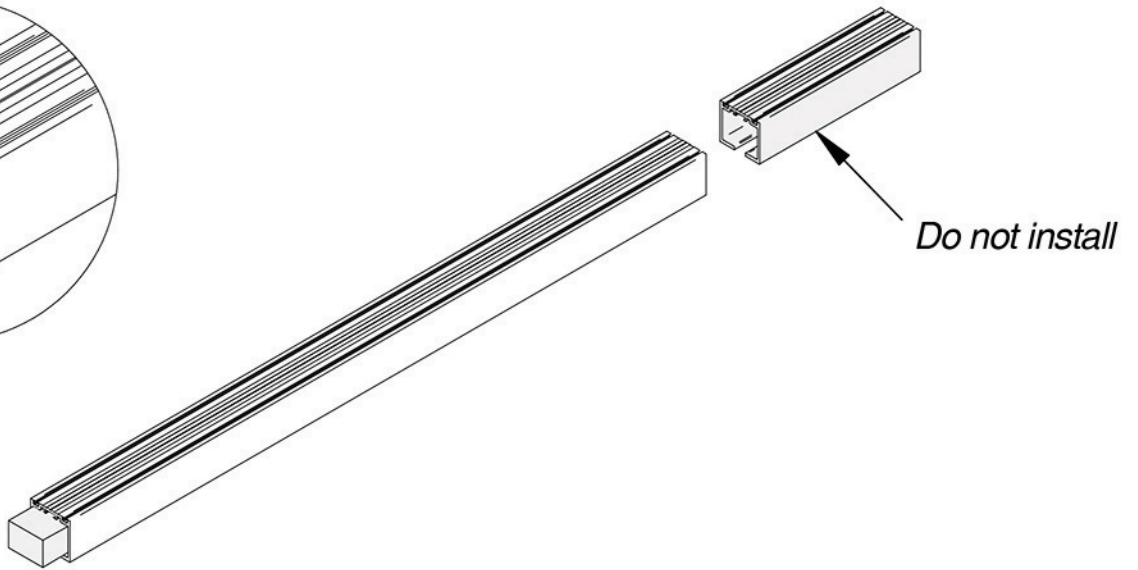
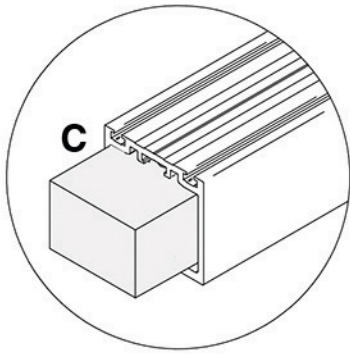

# 1b Profile fix

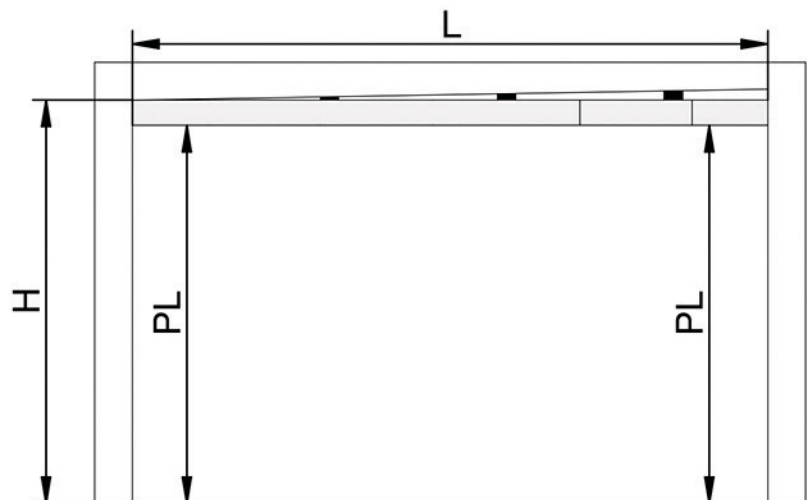
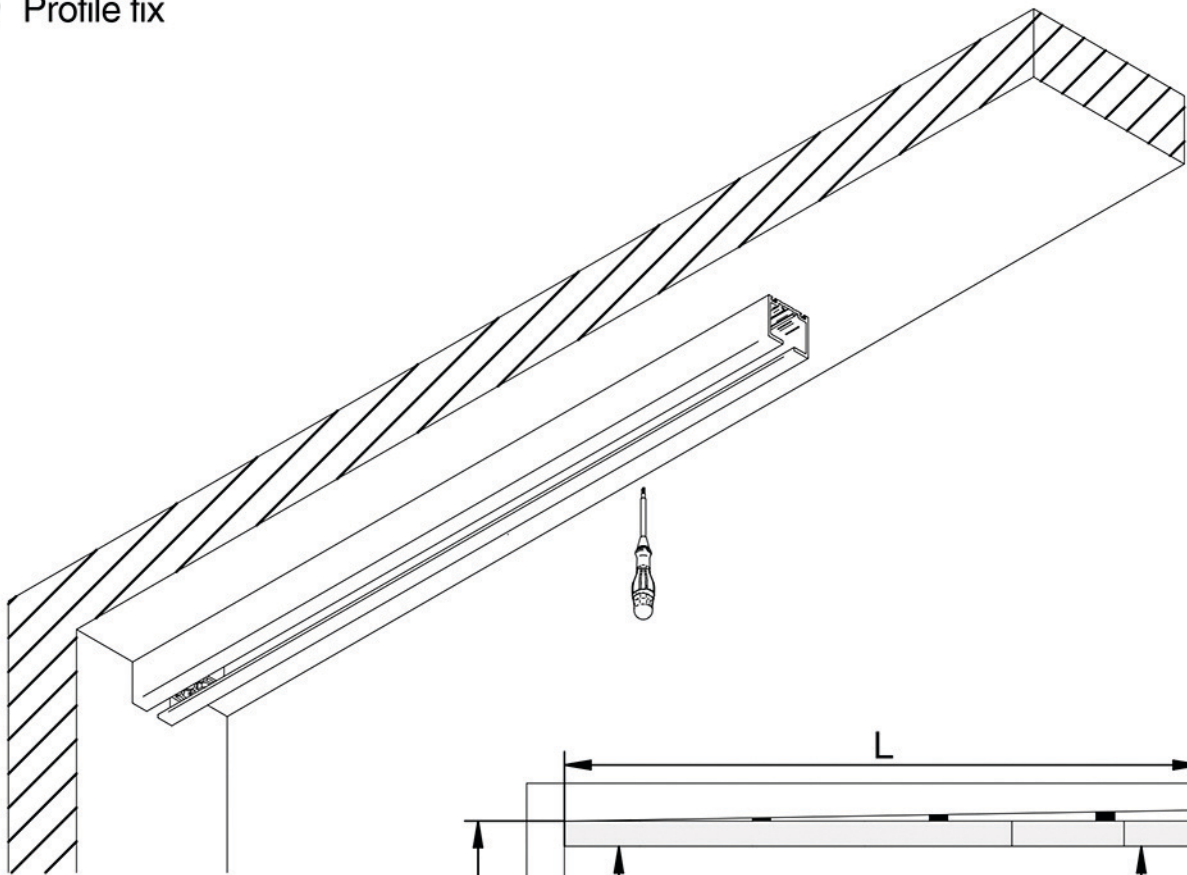

## 2 Assembly clamps profile

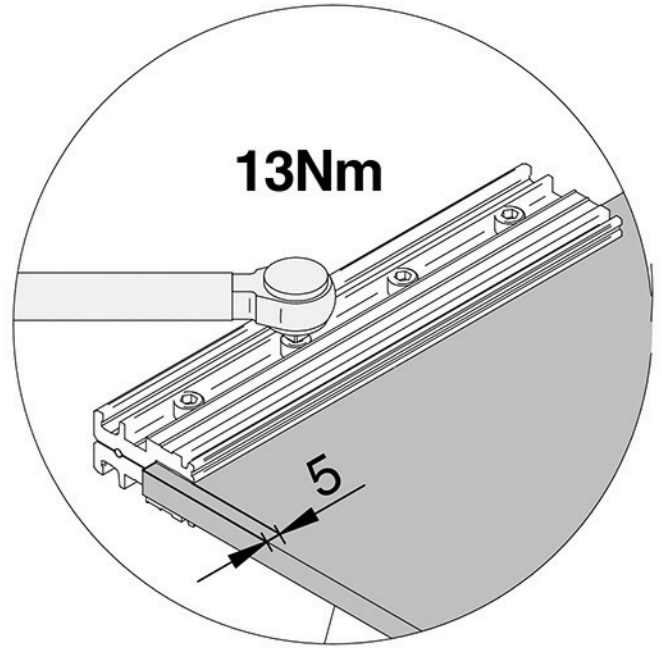
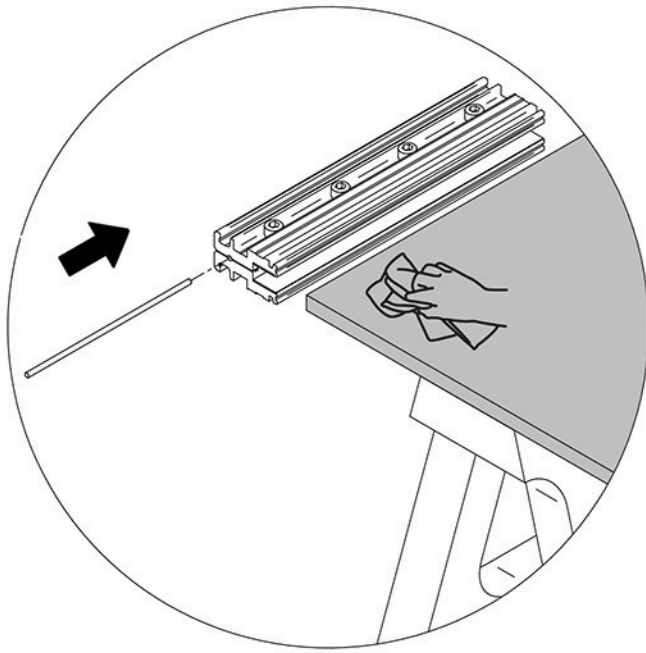

*Insert the spacer in the clamp*

*Place and screw the clamp on the clean panel*



Ø 3

10 mm

Ø 3,5

10,76 mm

Ø 4

12 mm

Ø 4,5

12,76 mm

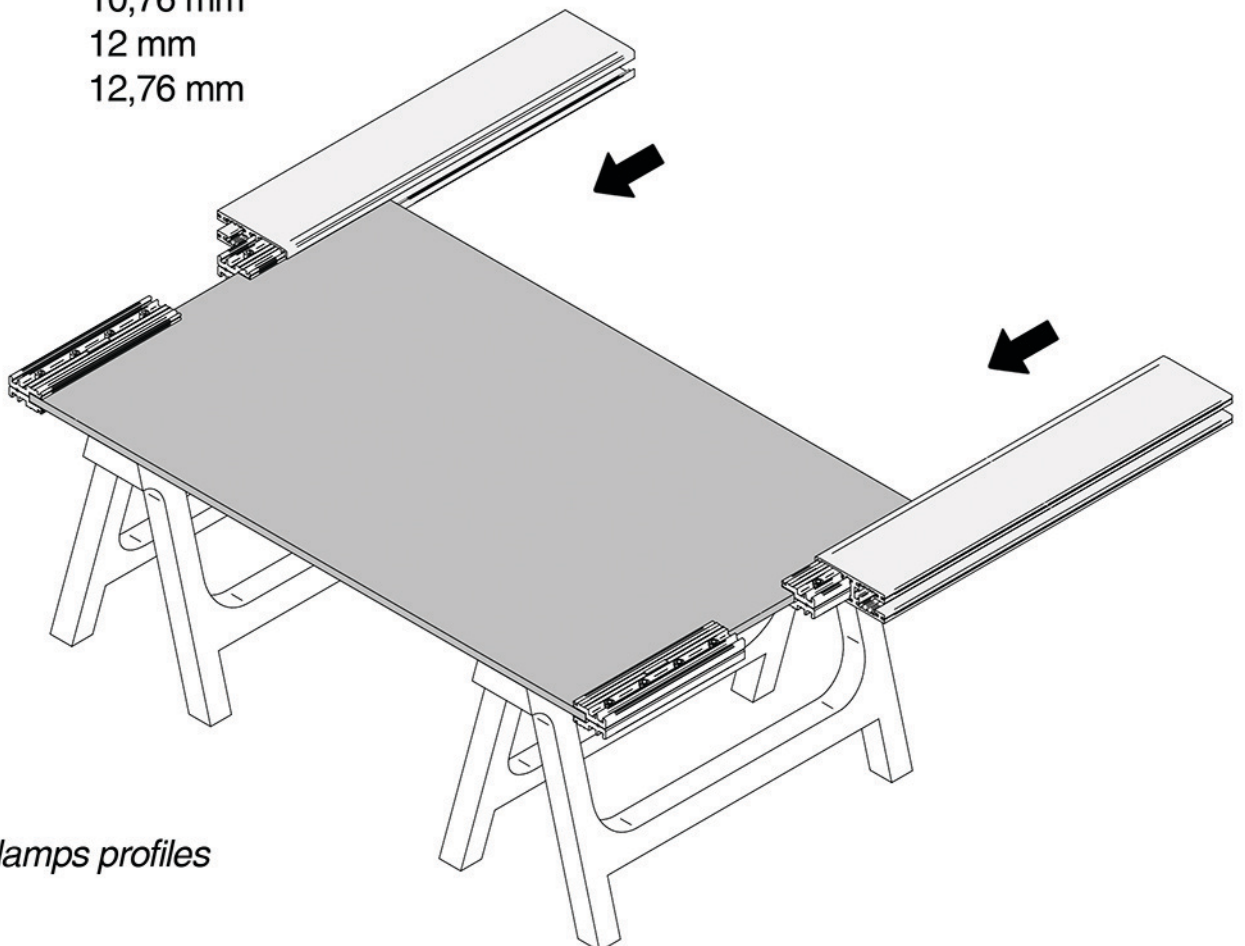

*Insert clamps profiles*

### 3 Tightening clamp profile

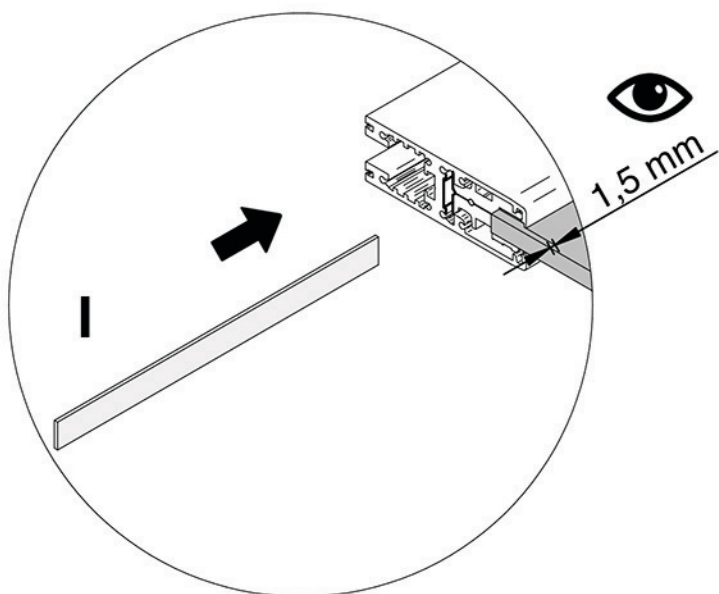

*Insert the platelet in the clamp profile*

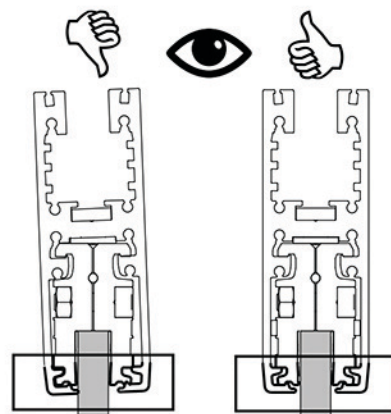

*Verify the right position of the clamp*

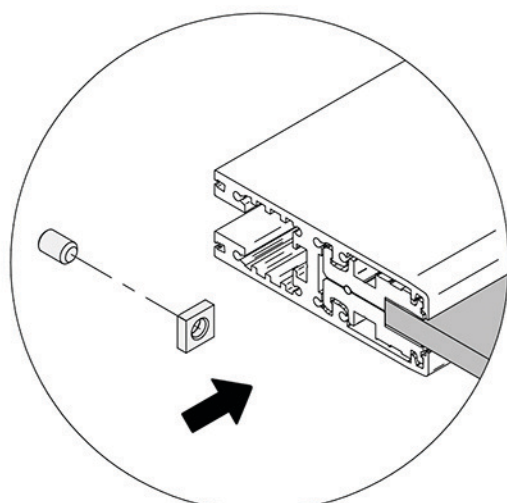
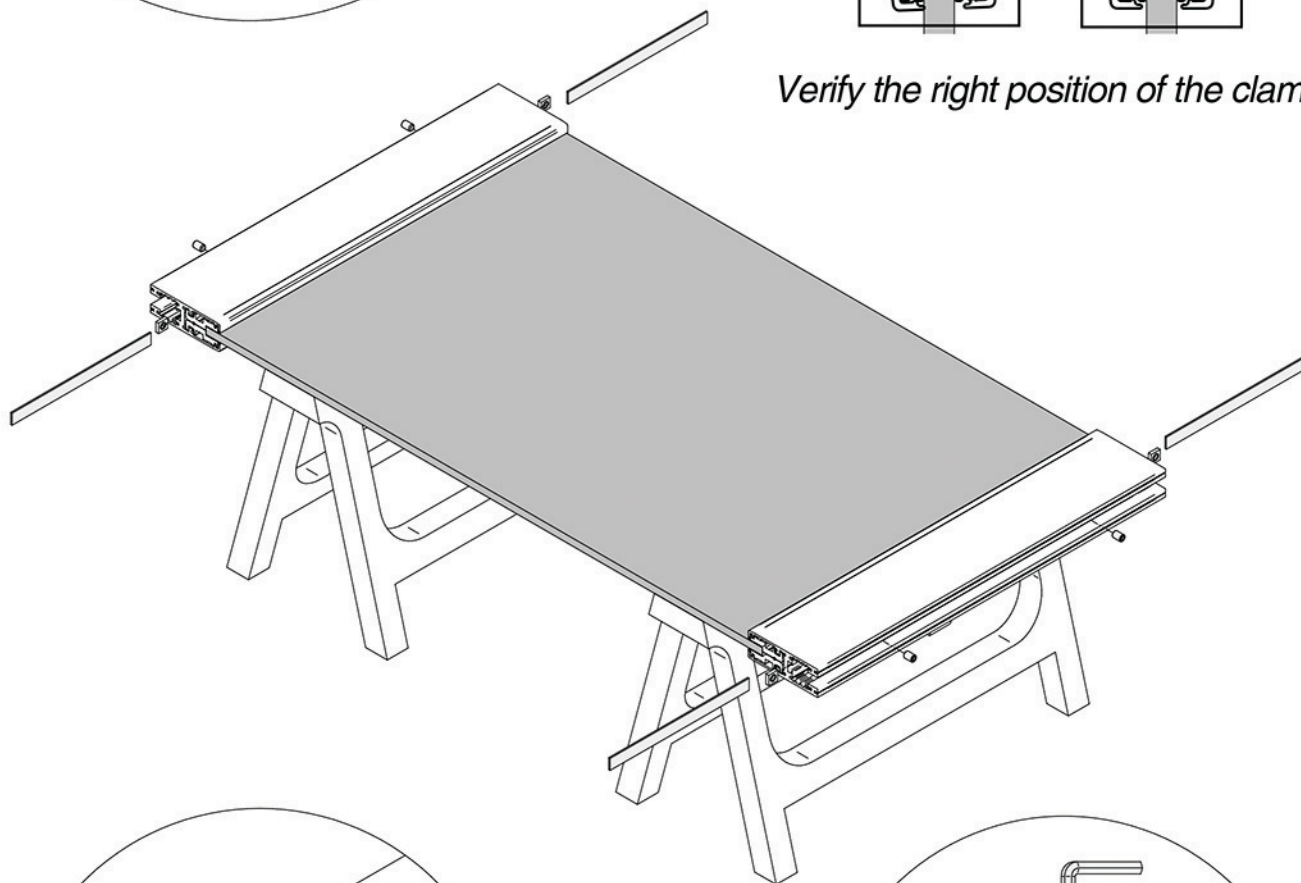

*Screw*

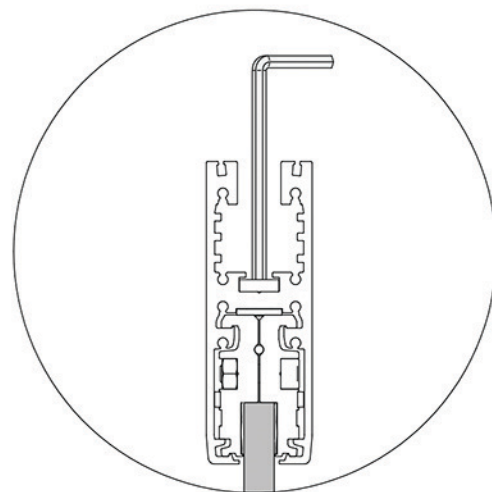

# 4 Assembly panel "A"

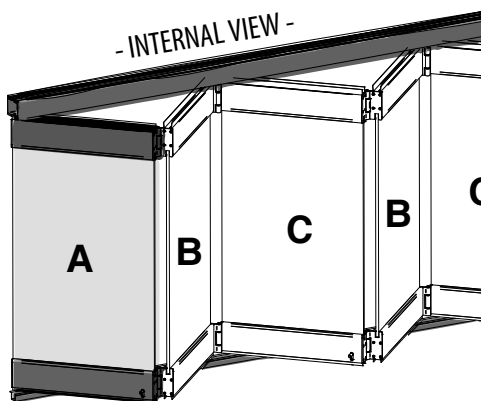
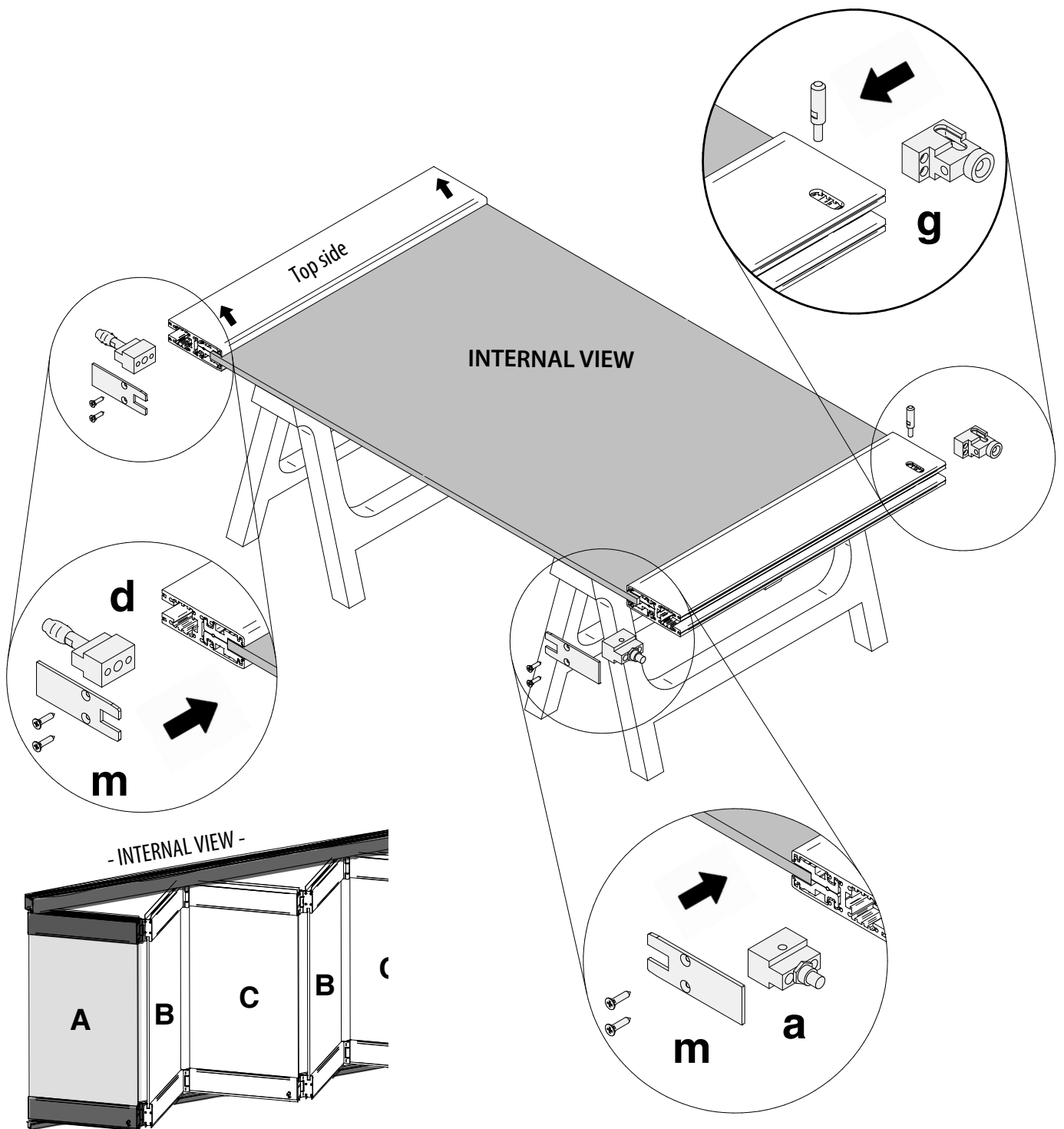
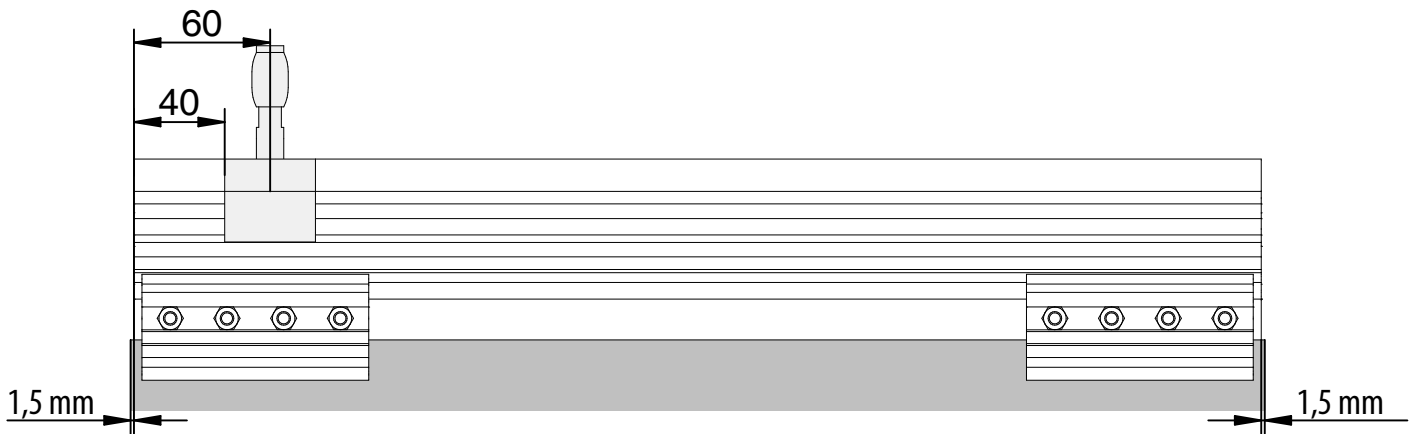

# 5 Assembly panel "B"

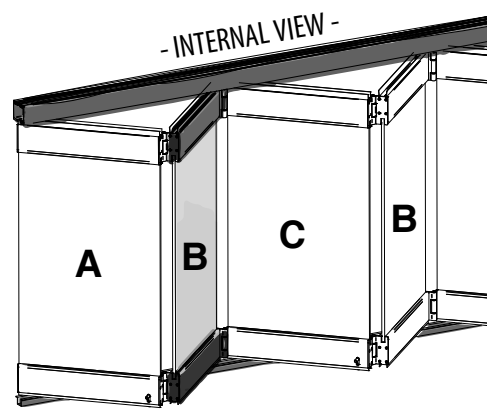
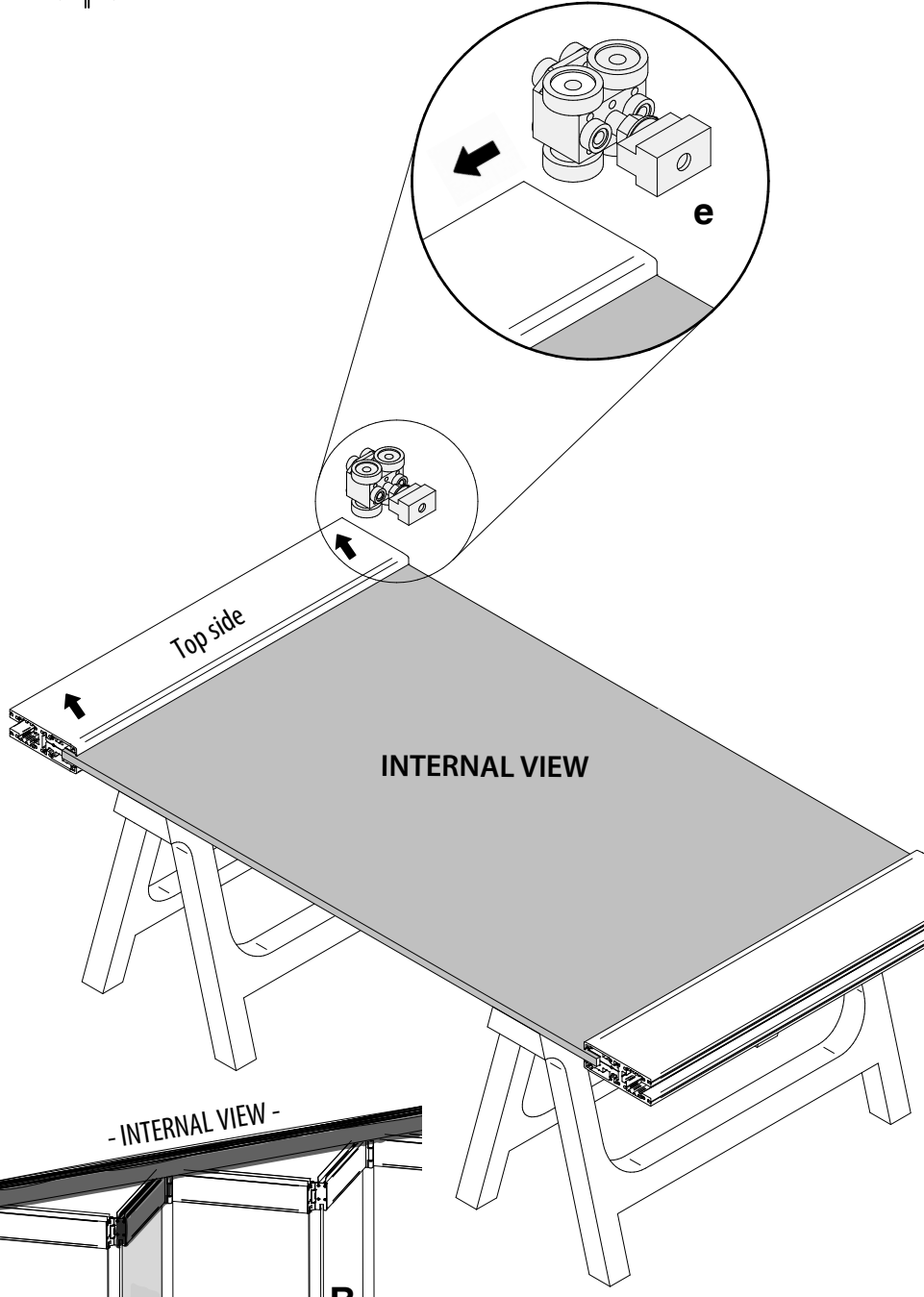
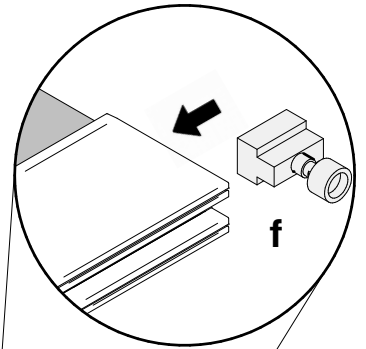
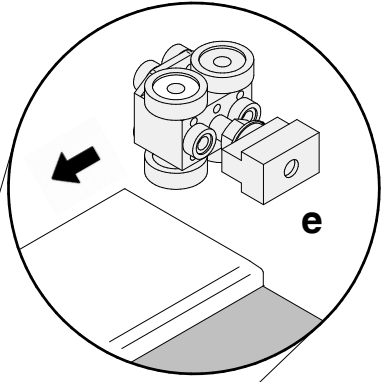
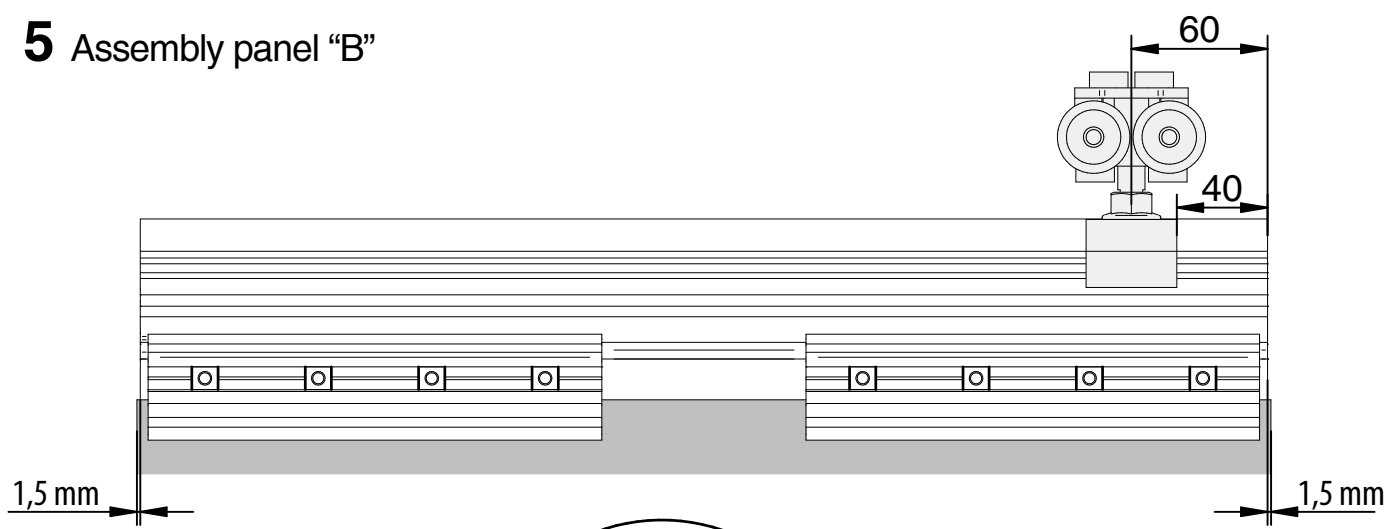



## 6 Assembly panel "C"

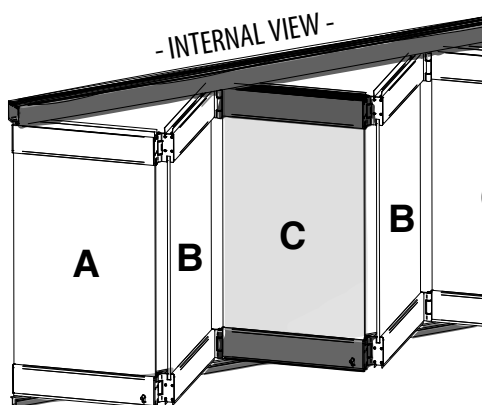
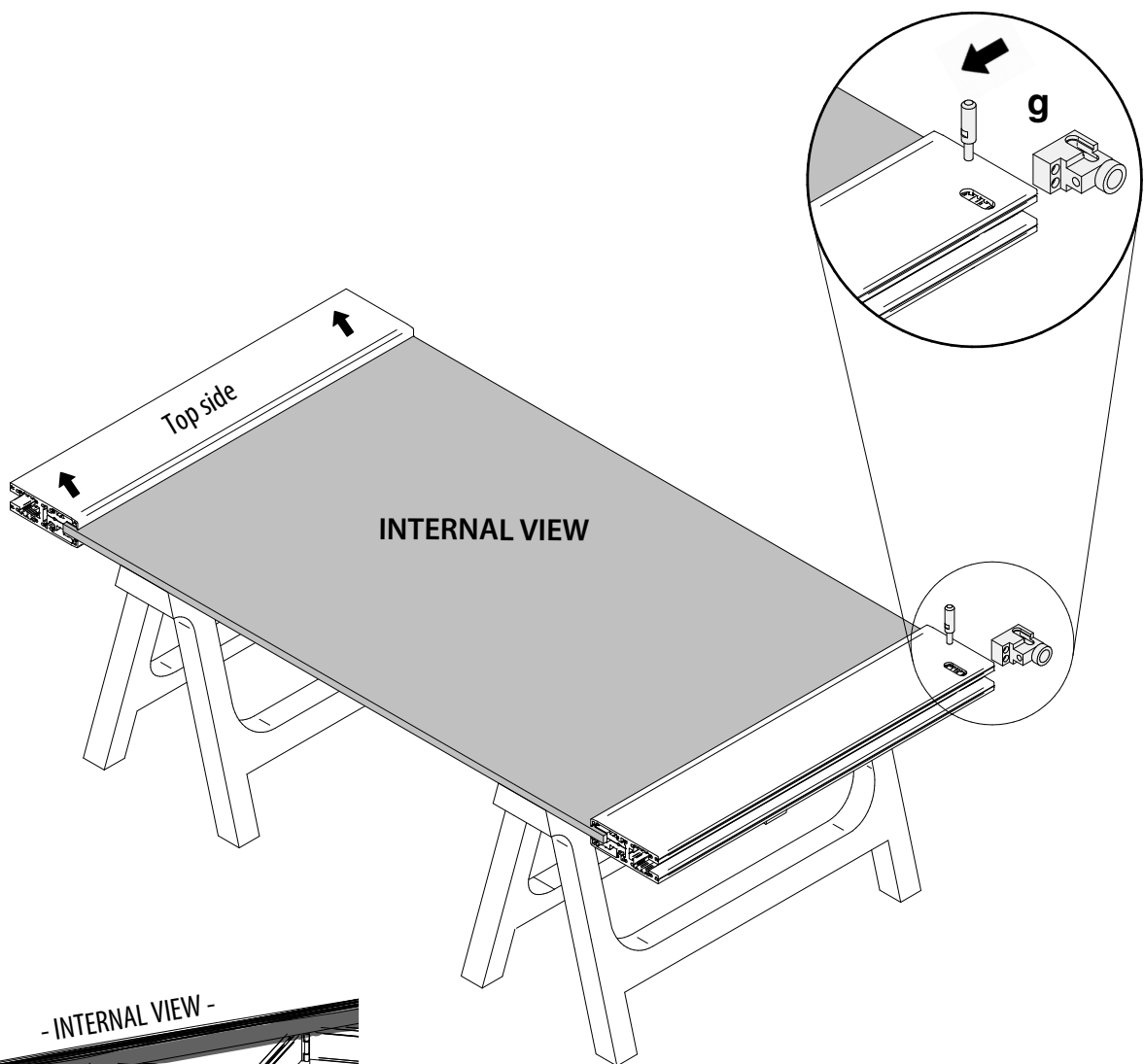
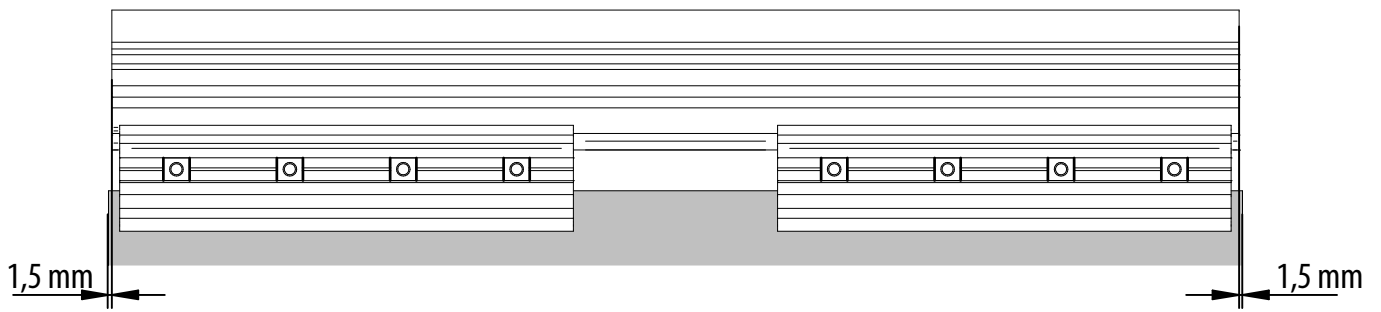

# 7 Assembly panel "D"

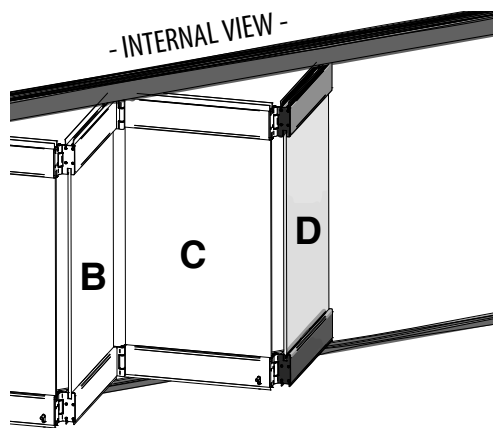
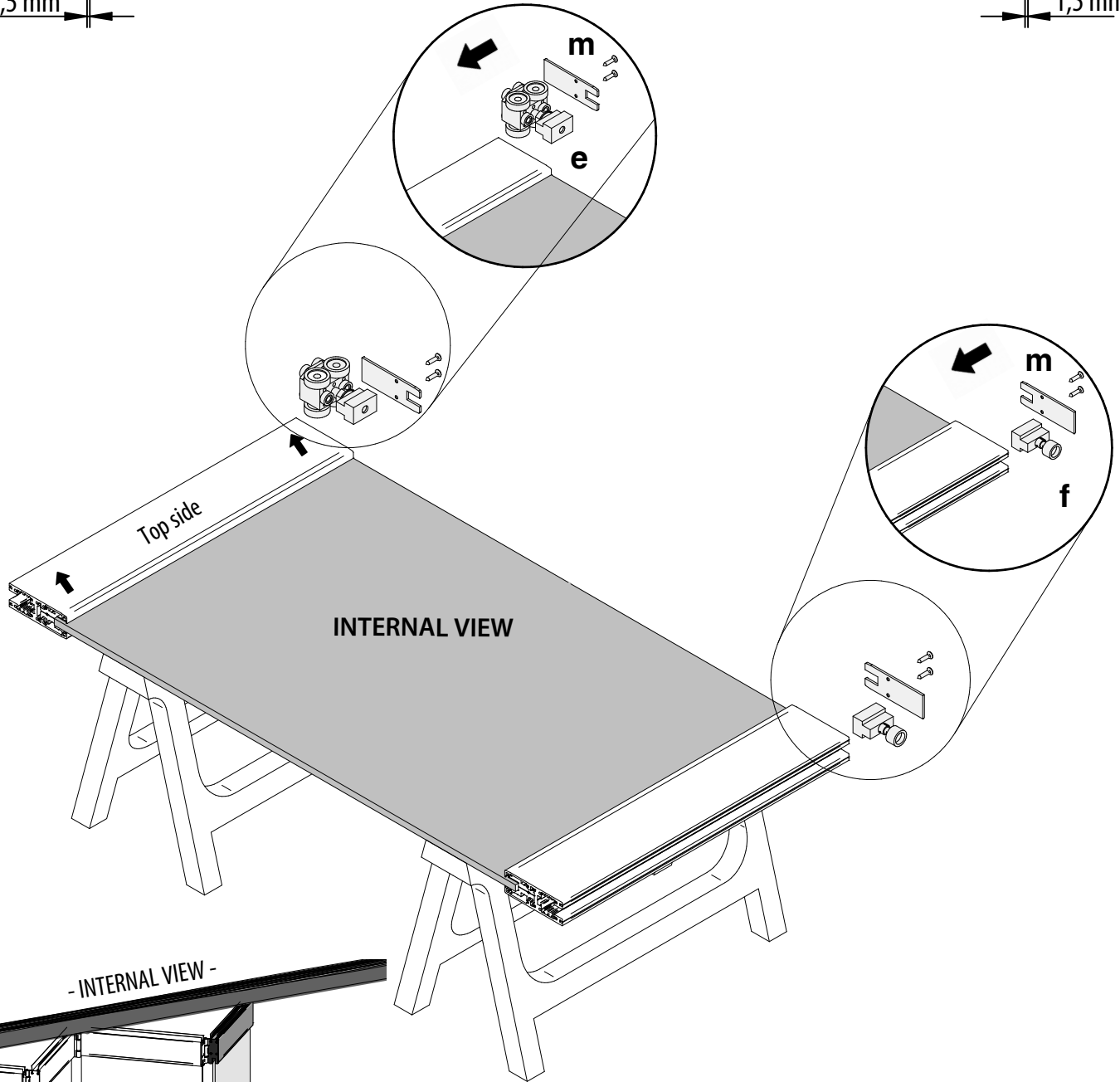
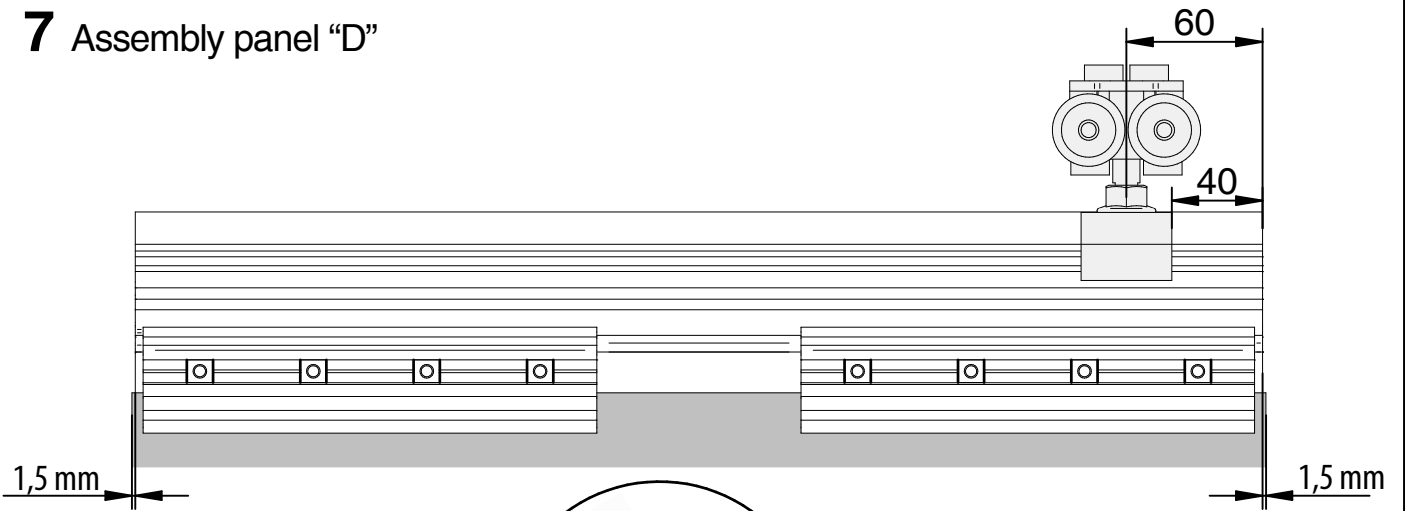

# 8 Assembly panel "E"

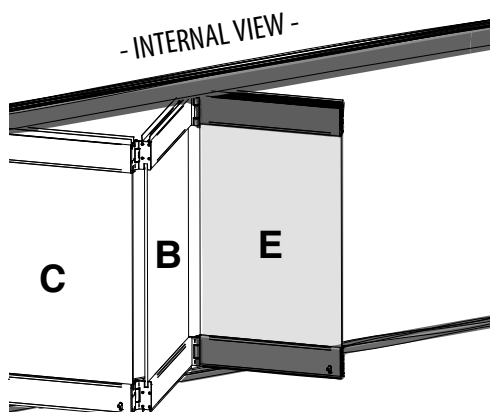
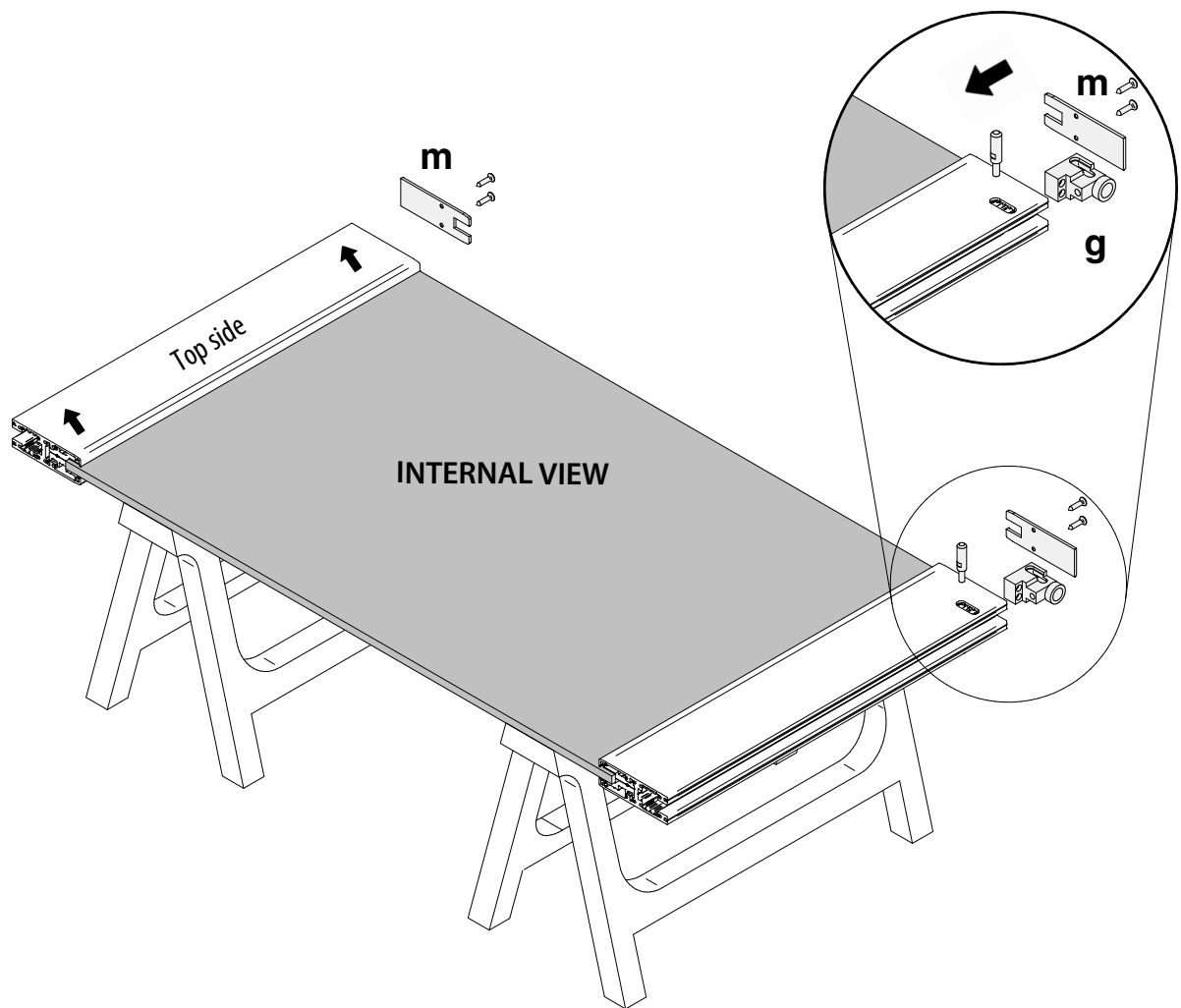
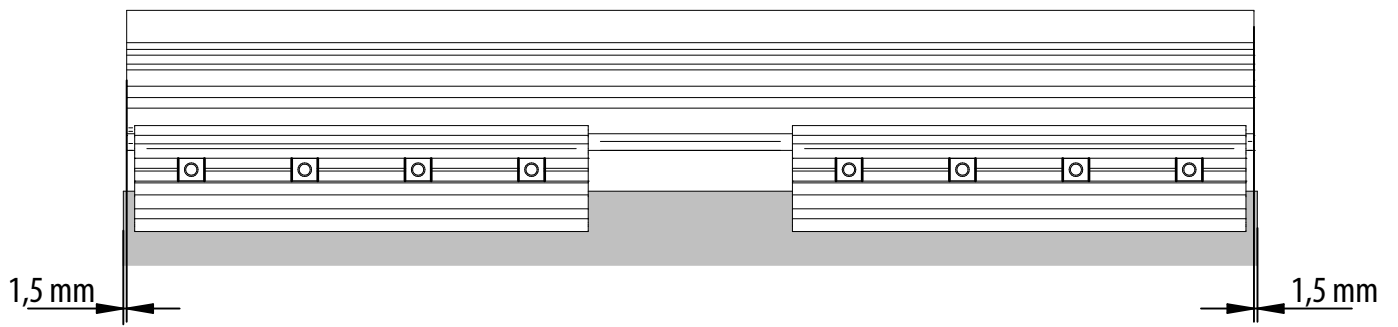

# 9 Assembly panel "F"

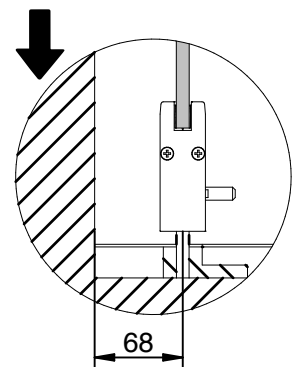
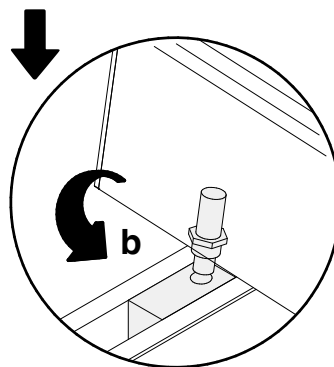
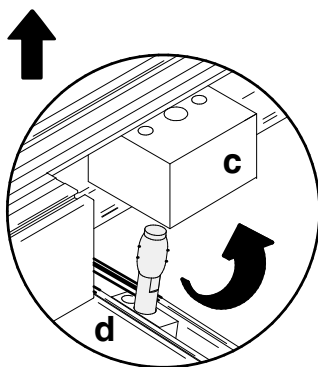
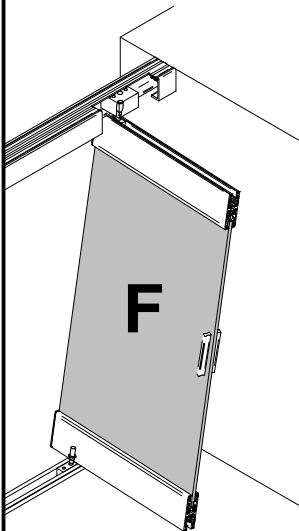
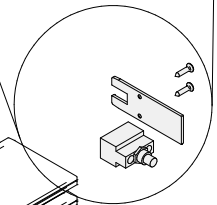
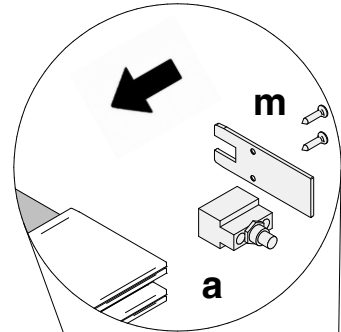
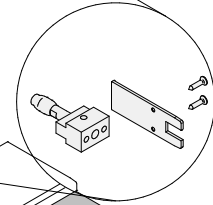
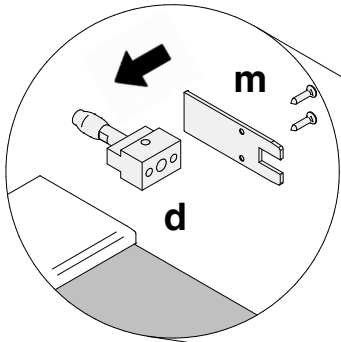
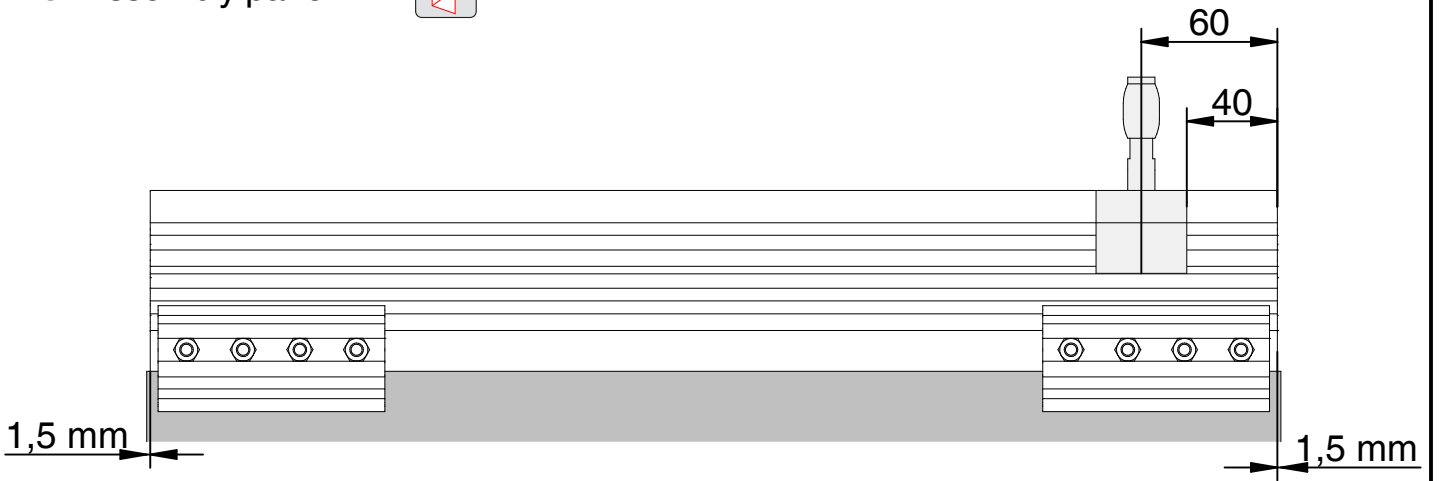

## 12 Assembly brushes and seals

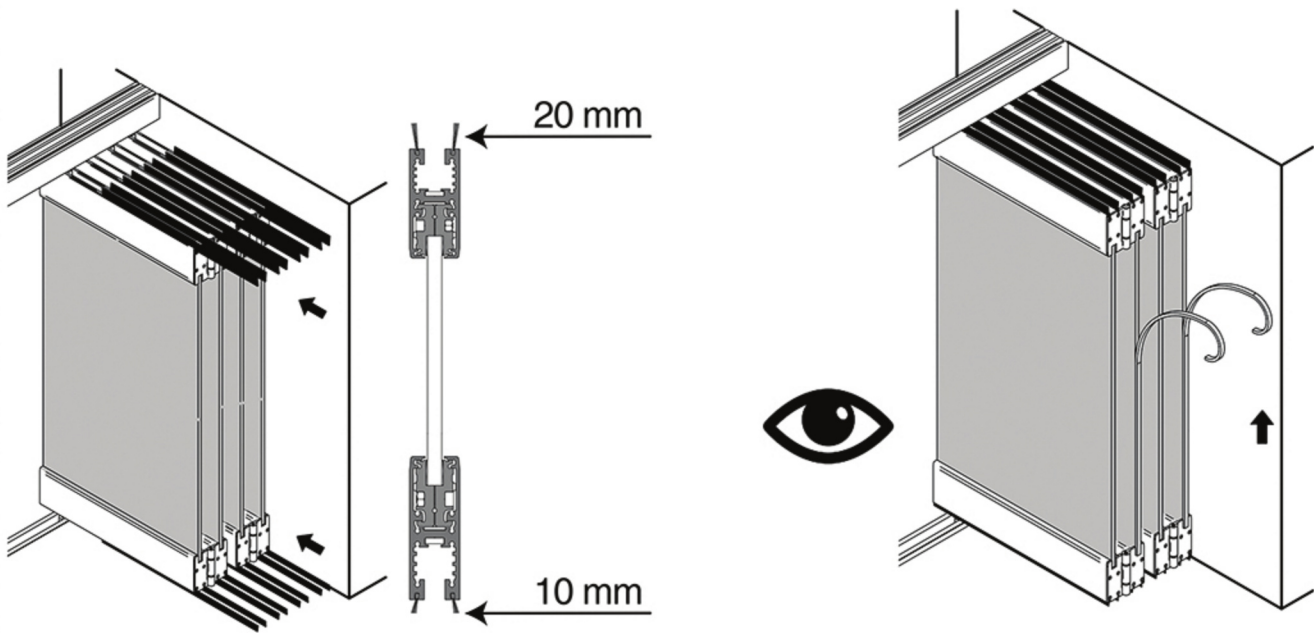

Clean with our glass cleaner Hendrika  
779118010000



Do not install on cold glass

## 13 Assembly floor bush

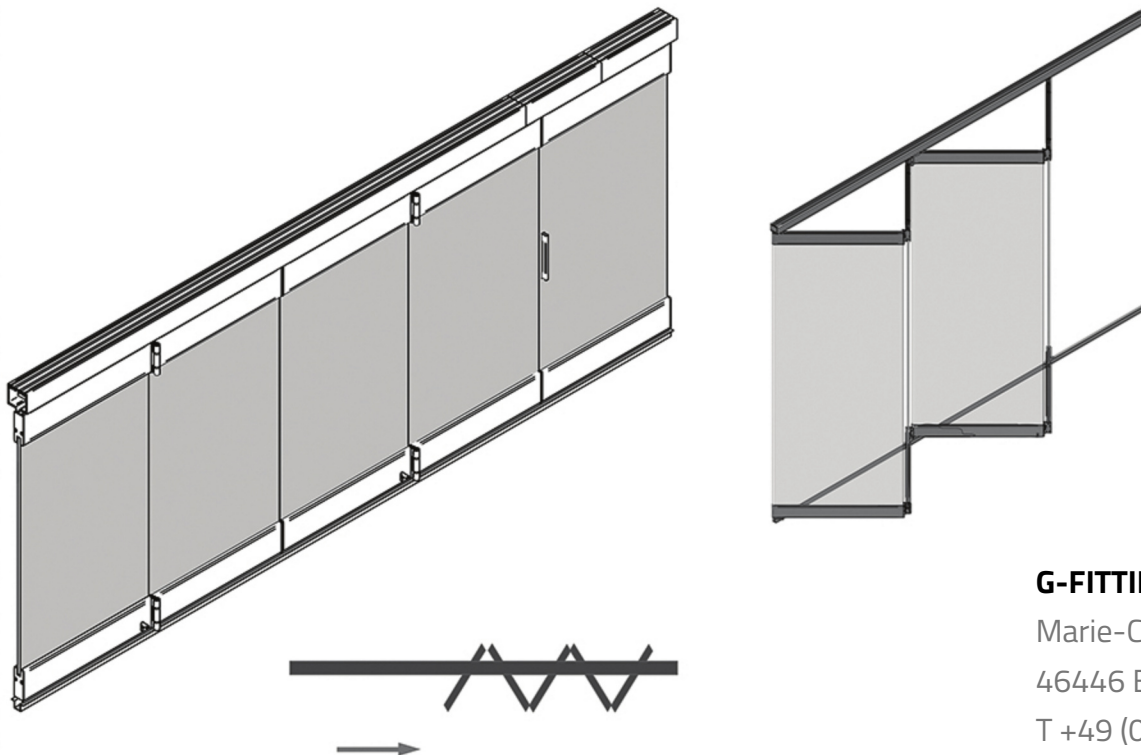

**G-FITTINGS GmbH**

Marie-Curie-Straße 16-18  
46446 Emmerich am Rhein  
T +49 (0)2822 962 0  
E sales@g-fittings.com

## 10 Mounting panel "A"

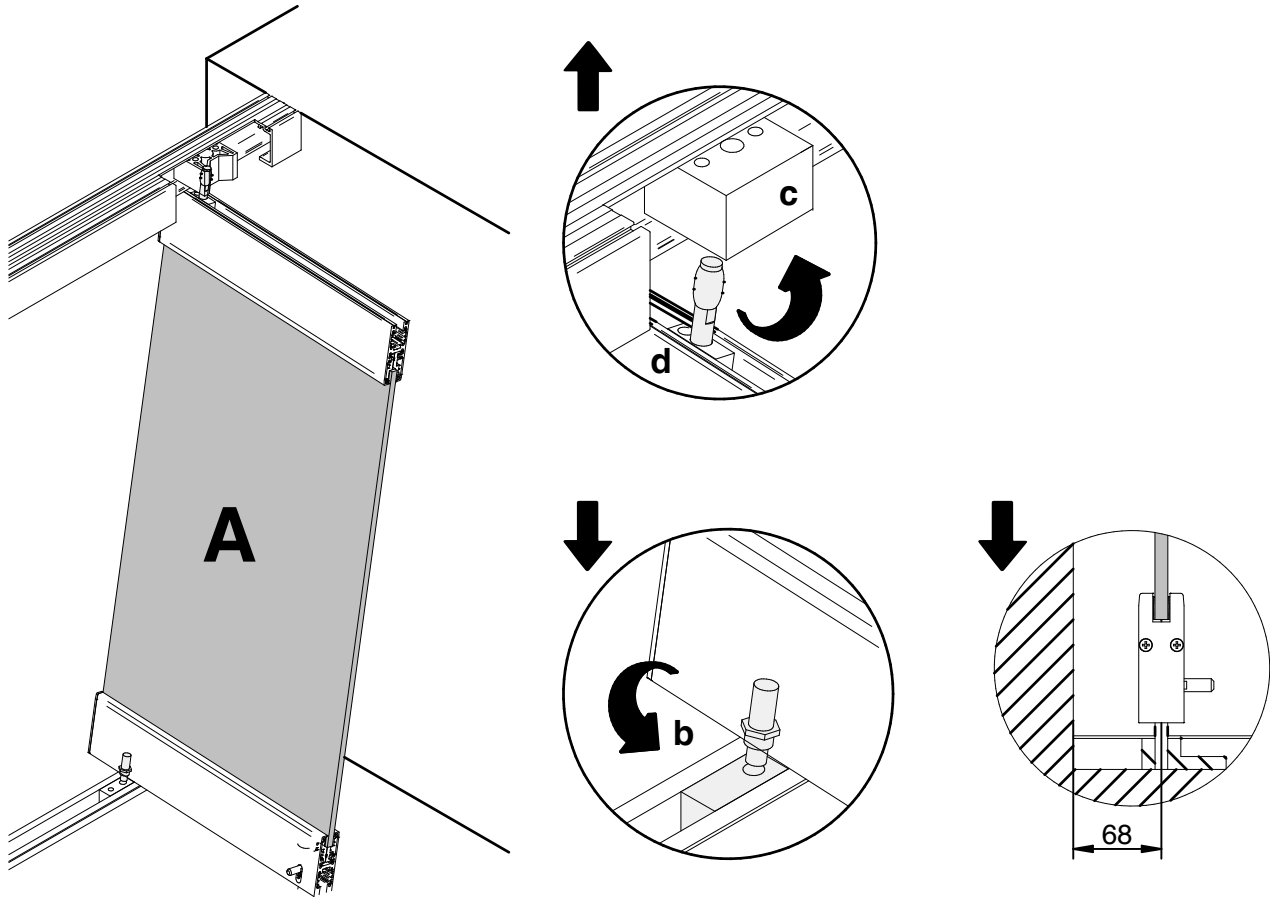

## 11 Panels mounting

