

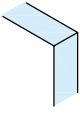
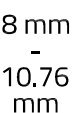
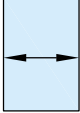
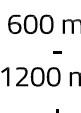

Technische Daten:
 Glas Schiebetür - LENA / Wandmontage

Datasheet:
 Sliding glass door - LENA / wall mounting

Art. 77462000250-46

Ausführung:  8 mm
Options:  10.76 mm

 600 mm
 1200 mm

 80 kg max.

 Glas auf Anfrage-
 Nicht Teil des
 Lieferumfanges!
 Glass upon request-
 Not in scope of supply!

 Keine
 Glasbohrungen
 nötig
 NO glass-
 machining
 needed

Material: Aluminium
Material: aluminum

Gewicht: / Weight: 11,76 kg

Oberflächen: Silber matt eloxiert
Finish: silver mat anodised

Lieferumfang:
 Scope of supply:

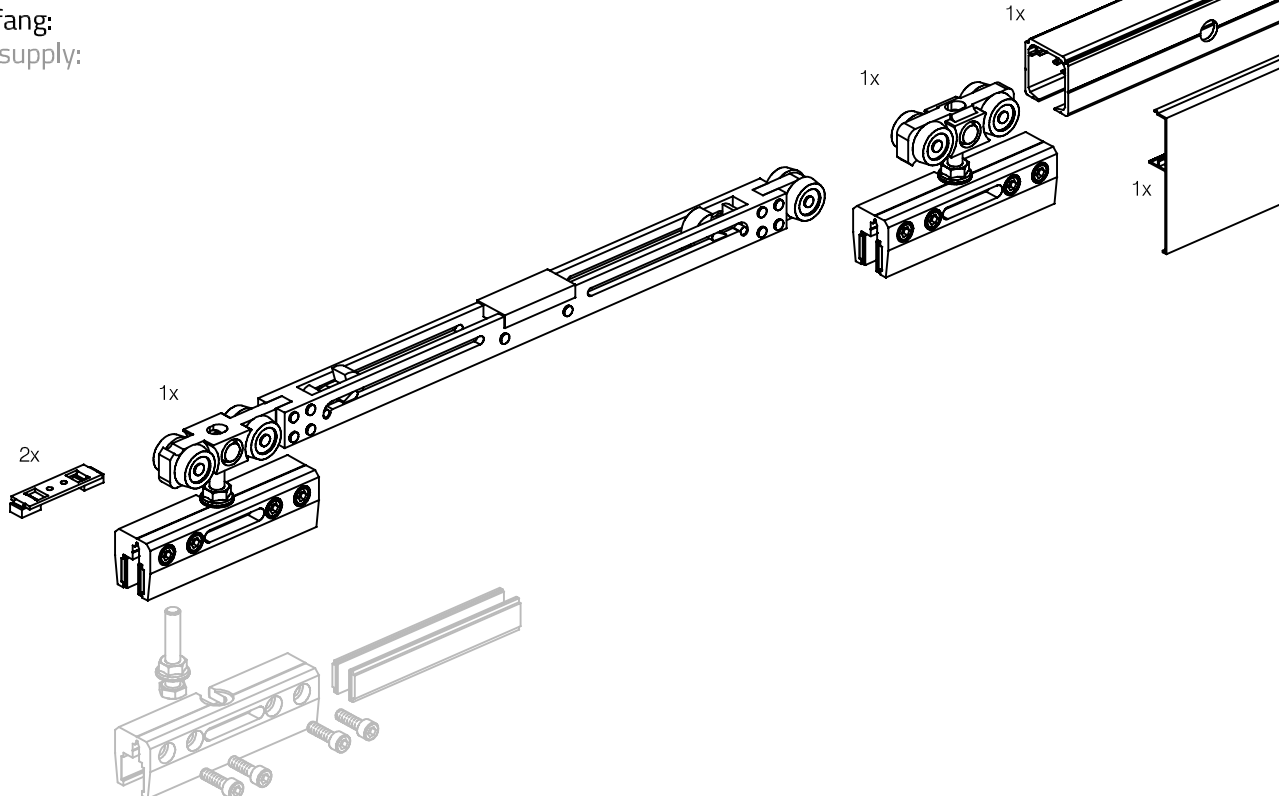
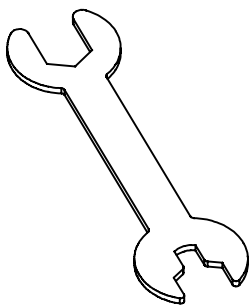
1x Montageschlüssel
 1x mounting key

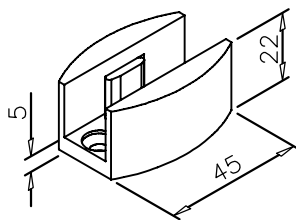

1x Bodenführung
 1x floor guide

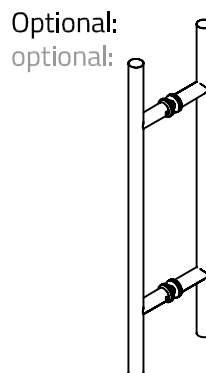

2x 47.5305.019.12 Türgriff, Adriana
 2x 47.5305.019.12 door handle, Adriana

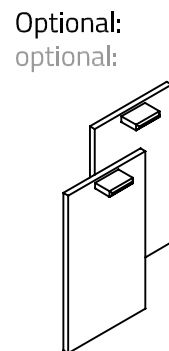

1x 46.2011.000.00 Endkappen
 1x 46.2011.000.00 Endcaps

Abmessungen:
Dimensions:

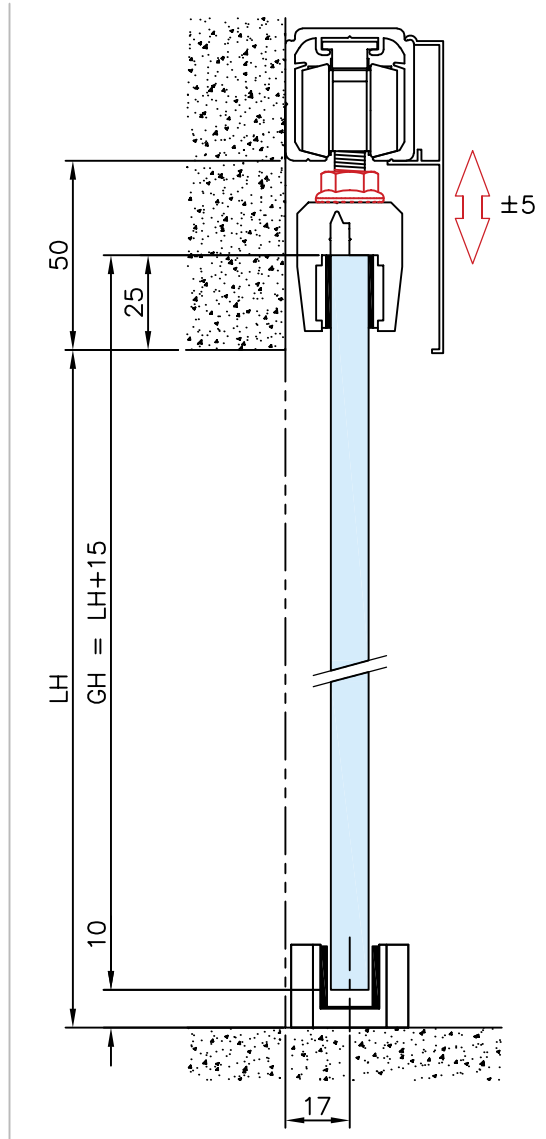
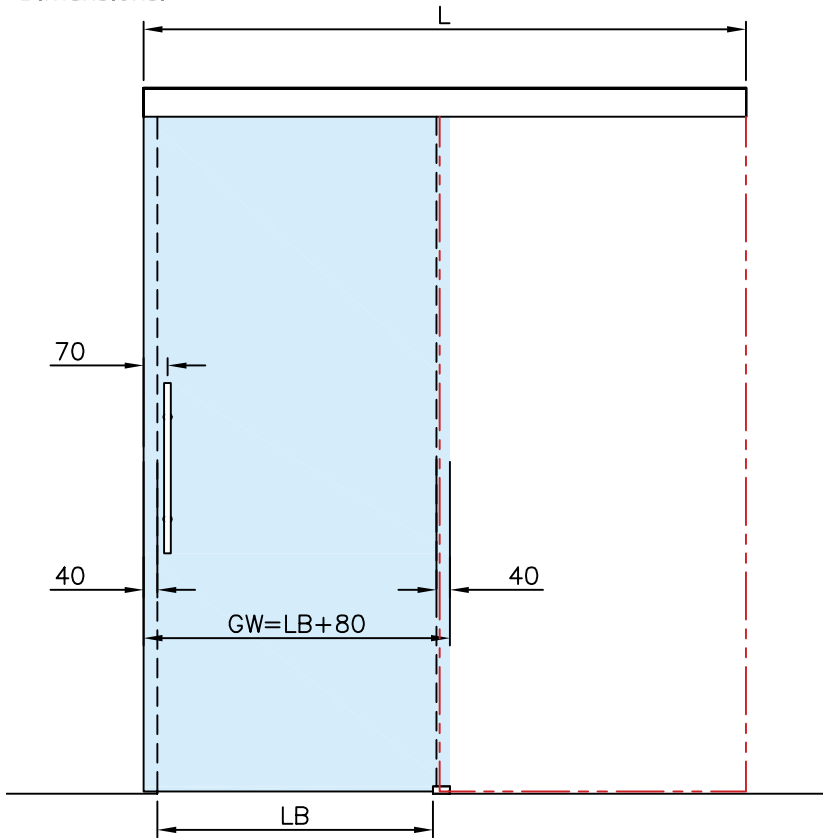

- LB = min. 520mm - max. 1120mm
- GW = LB + 80mm (min. 600mm - max. 1200mm)
- $L = (GW \times 2) - 60$
- GH = LH + 15
- X = L - GW - 465

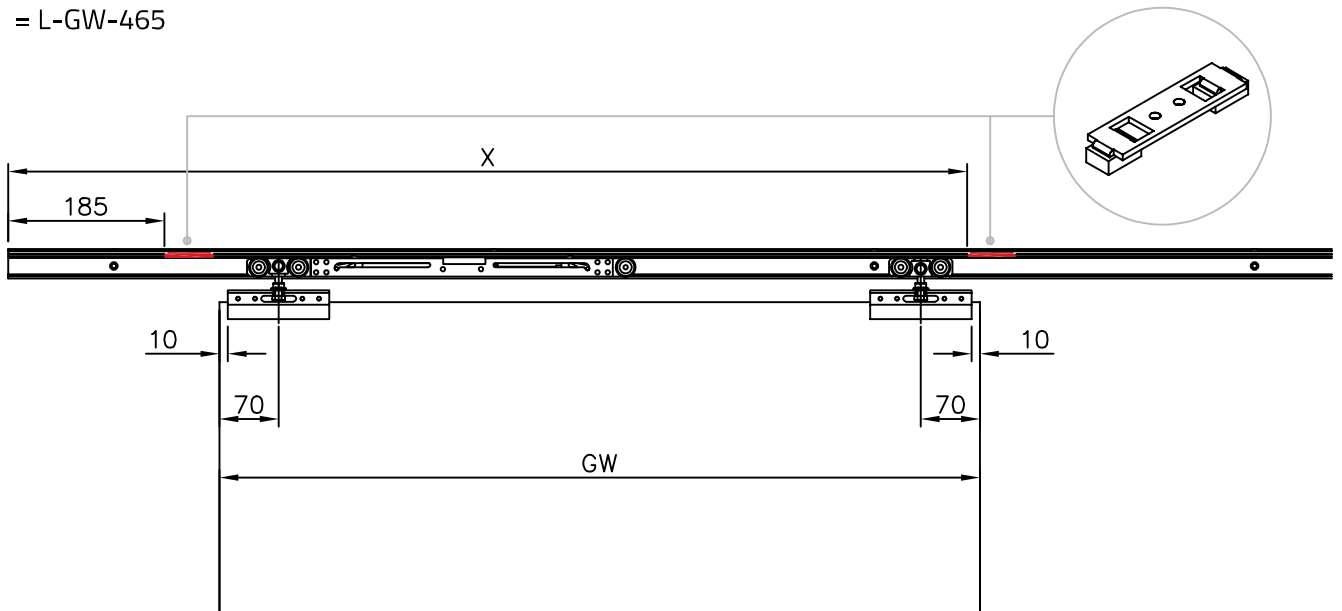

1. Laufschiene vorbereiten:
1. Prepare the running track:

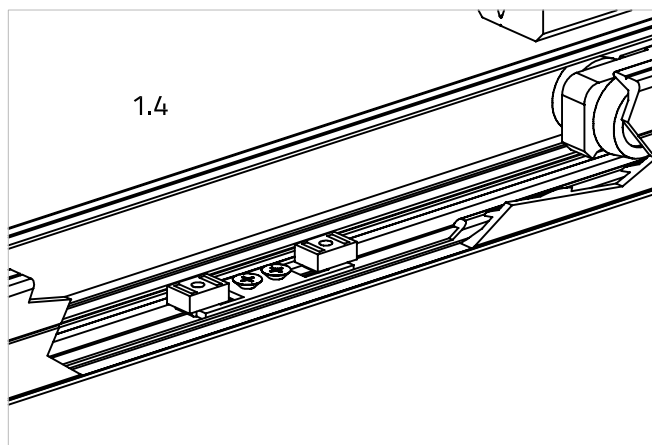
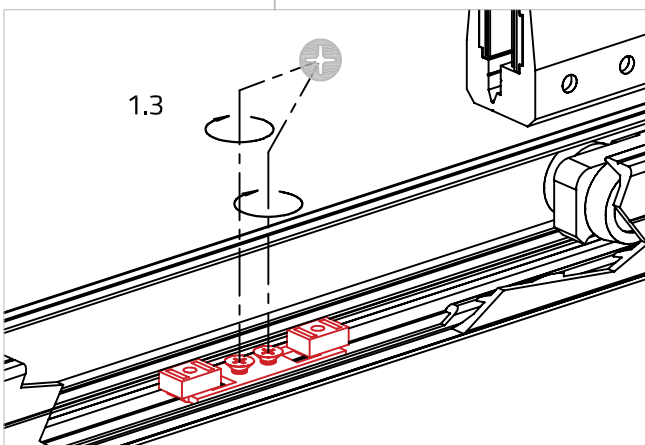
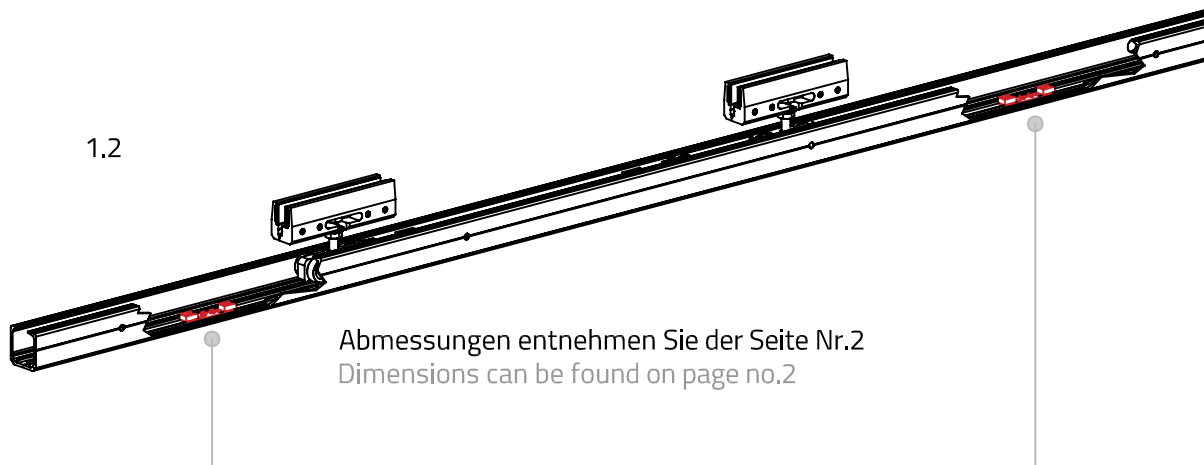
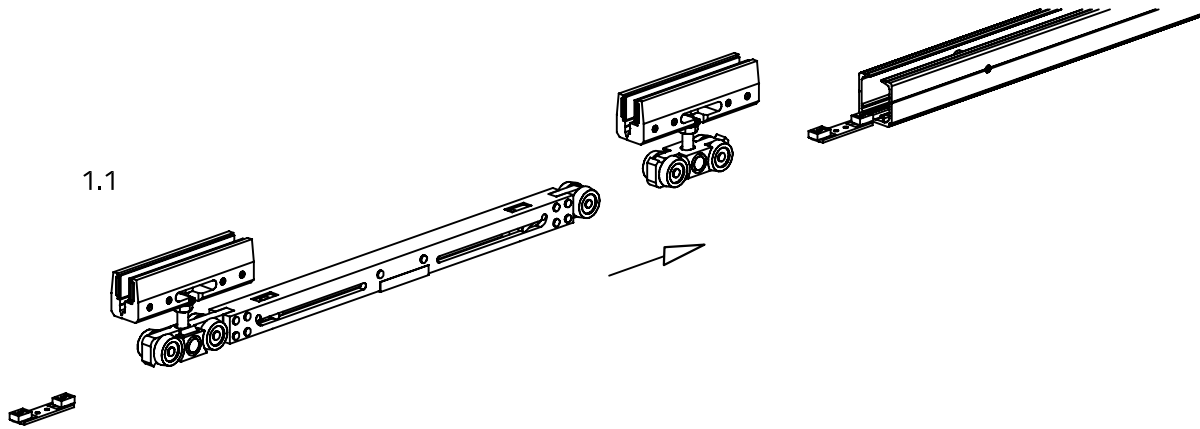

2. Laufschiene montage:
2. Running track

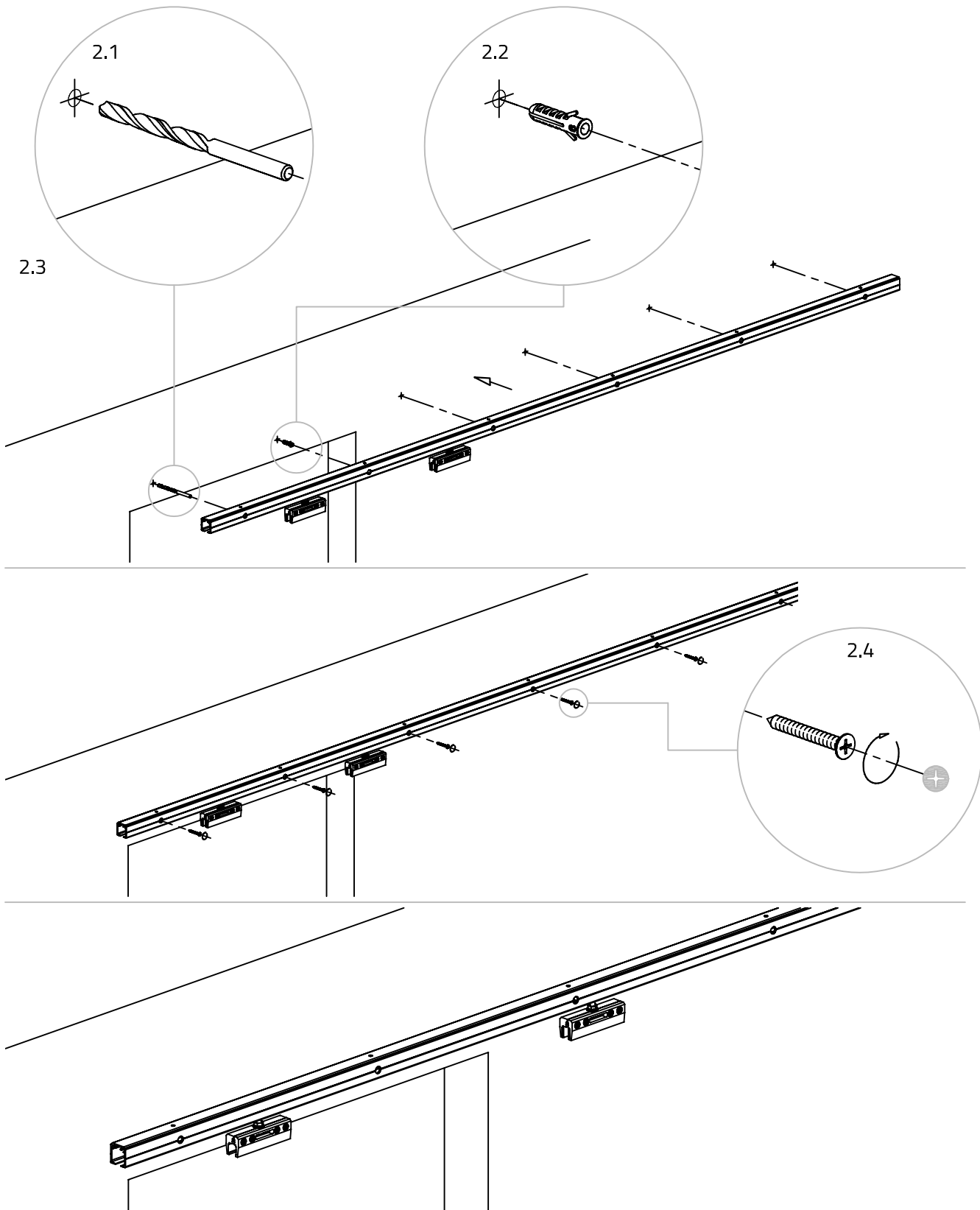

3. Glastüre vorbereiten

3. Prepare glass door

3.1

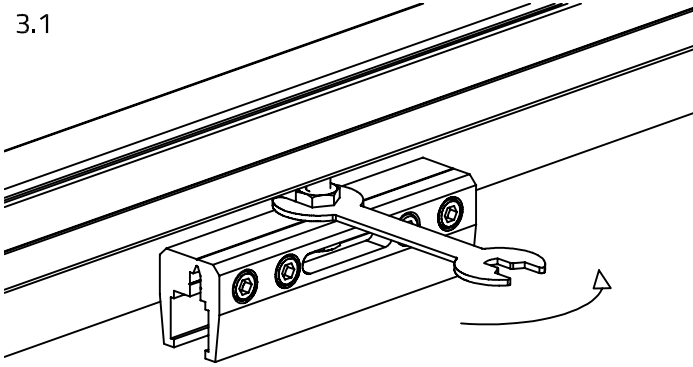

3.2

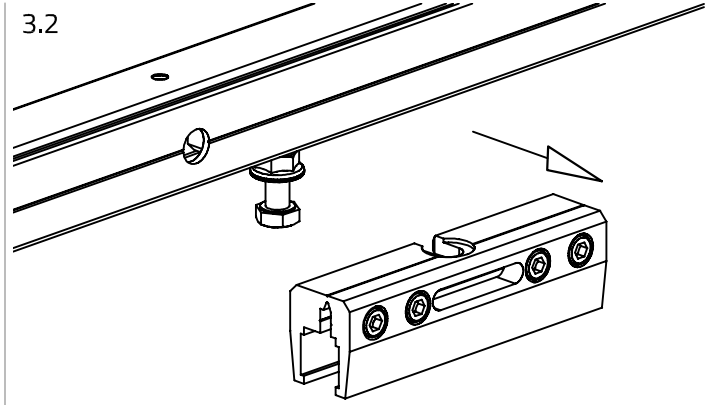

3.3

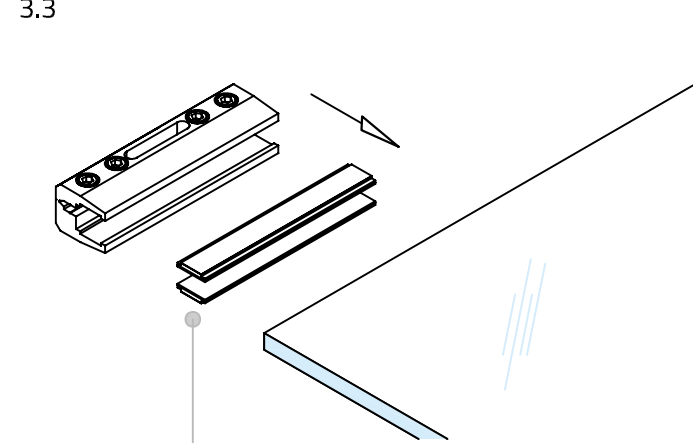

3.4

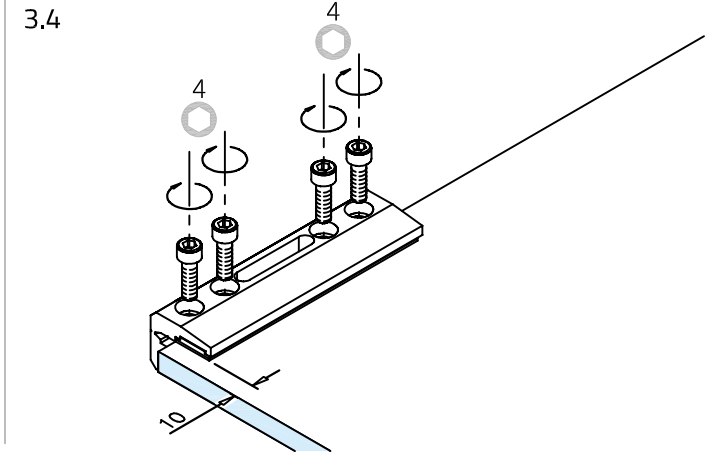

10 mm Glas
10 mm glass

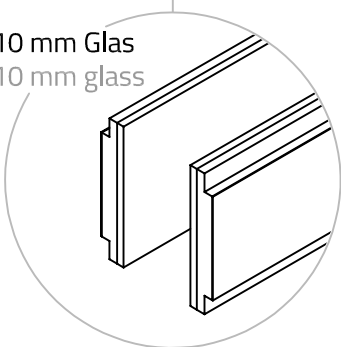

8 mm Glas
8 mm glass

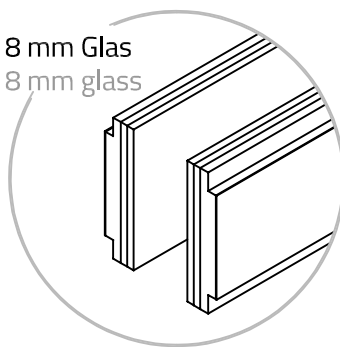

Wichtig: Vor der Montage das Glas im Bereich der Klebefläche reinigen. Wir empfehlen G-Fittings Glasreiniger art. 91.1800.000.00

Important: Before mounting, clean the glass in the area of the bonding surface. We recommend G-Fittings glass cleaner art. 91.1800.000.00

3.5

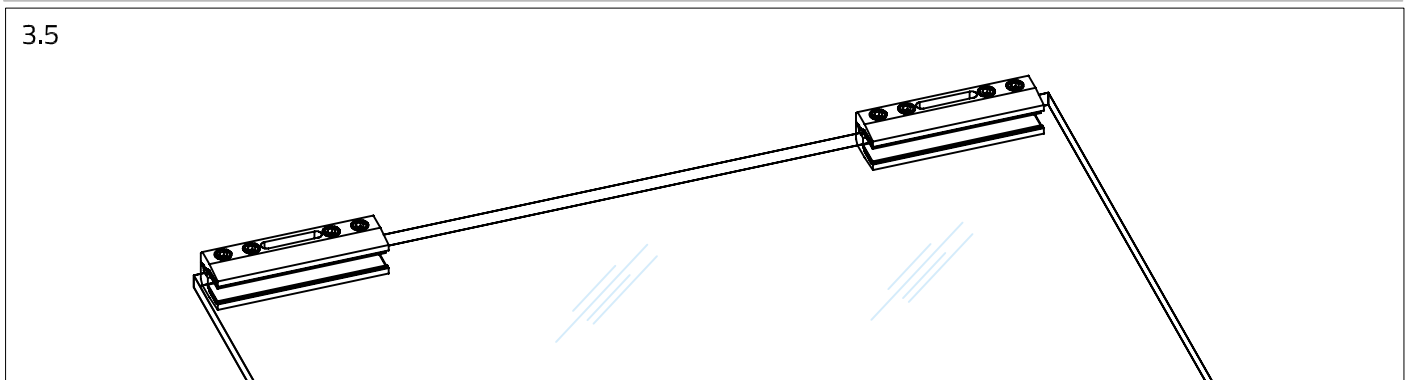

4. Bodenführung und Glastür montage

4. Door guide and glass door mounting

4.1

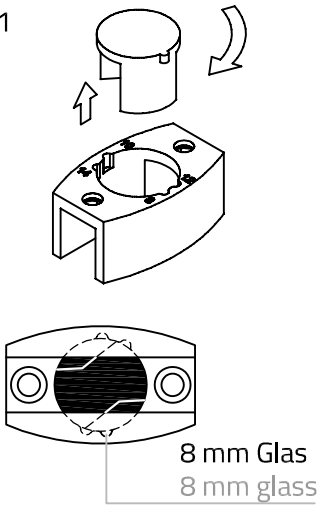

4.2

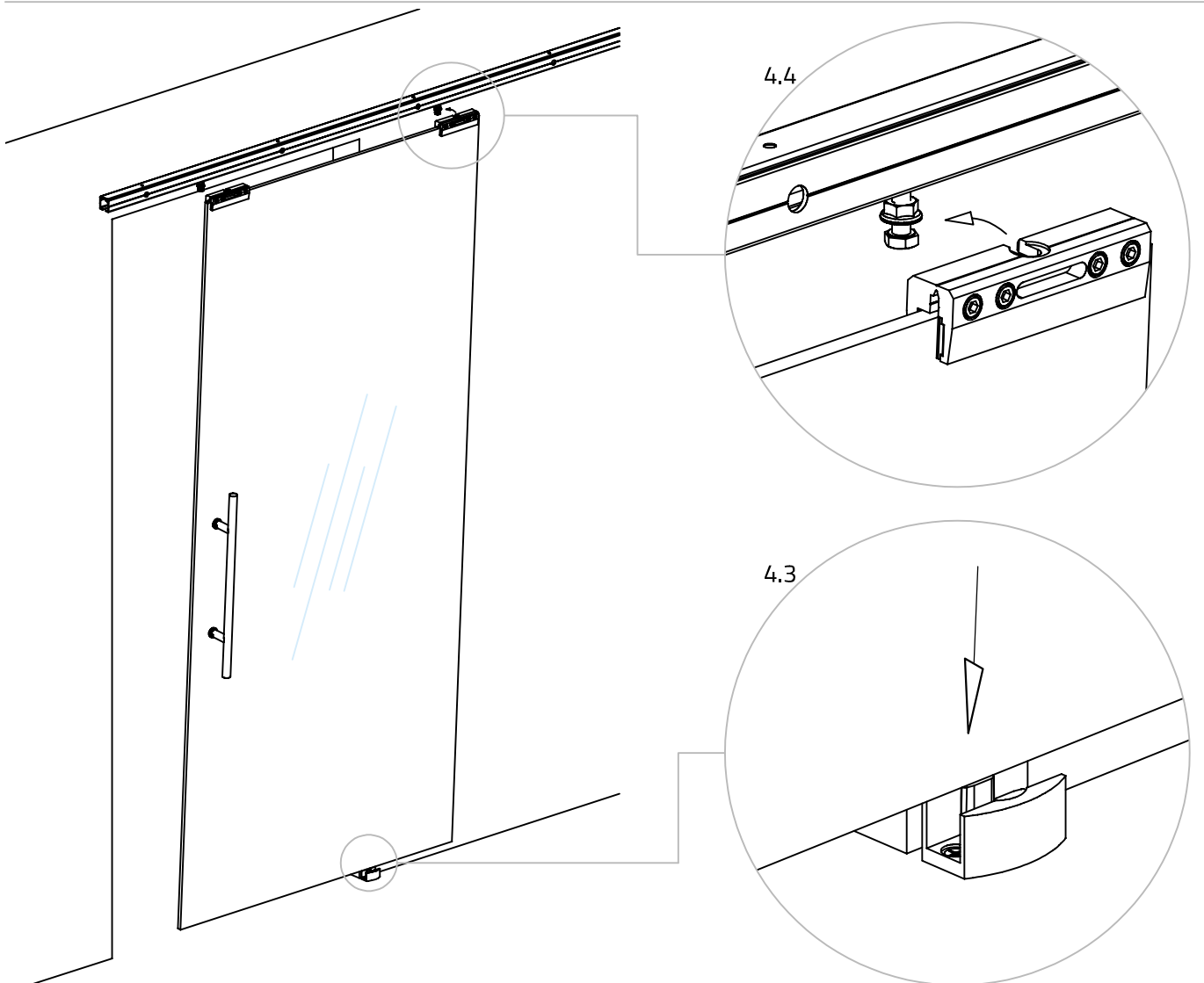
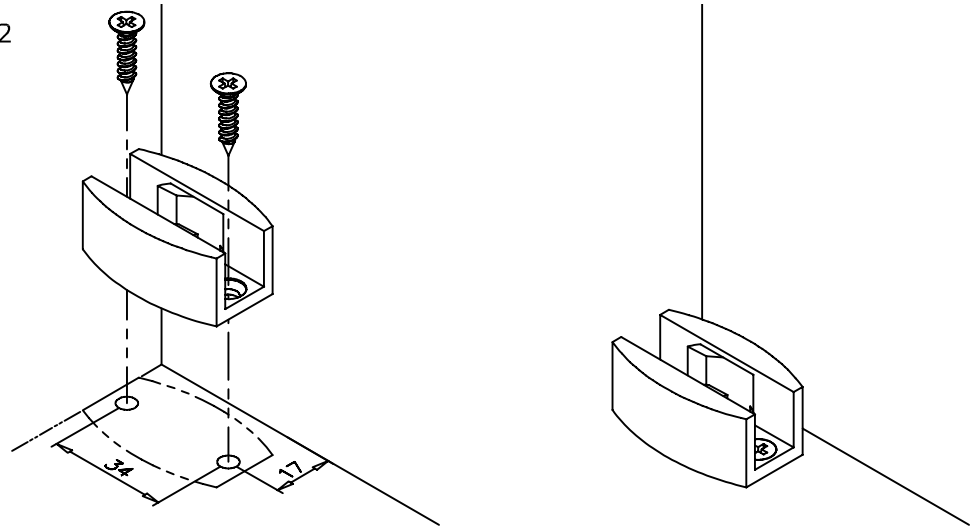

4.5

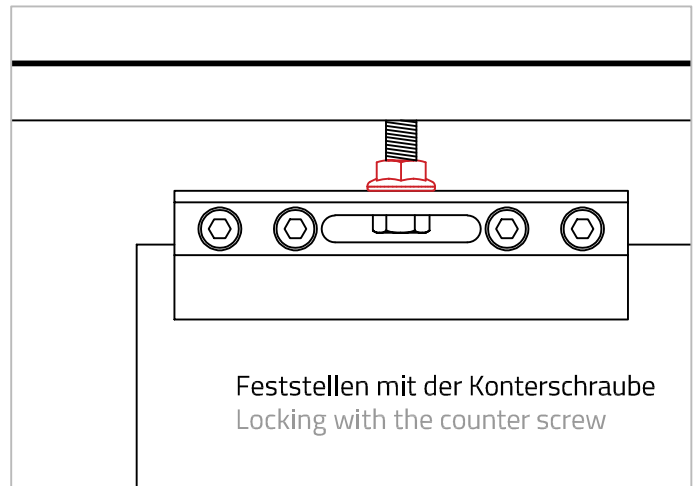
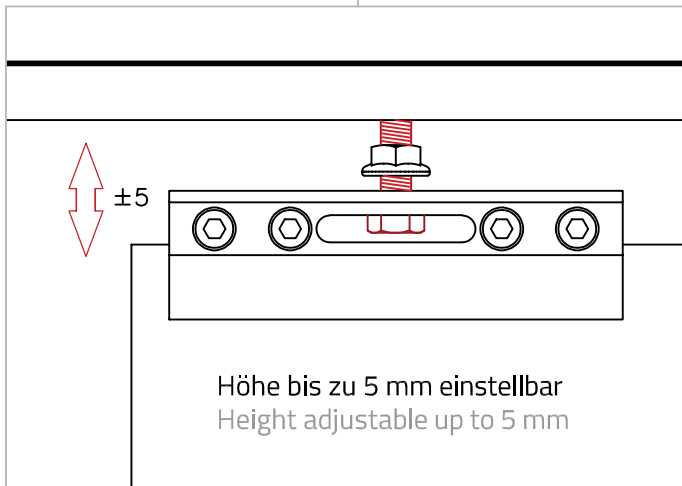
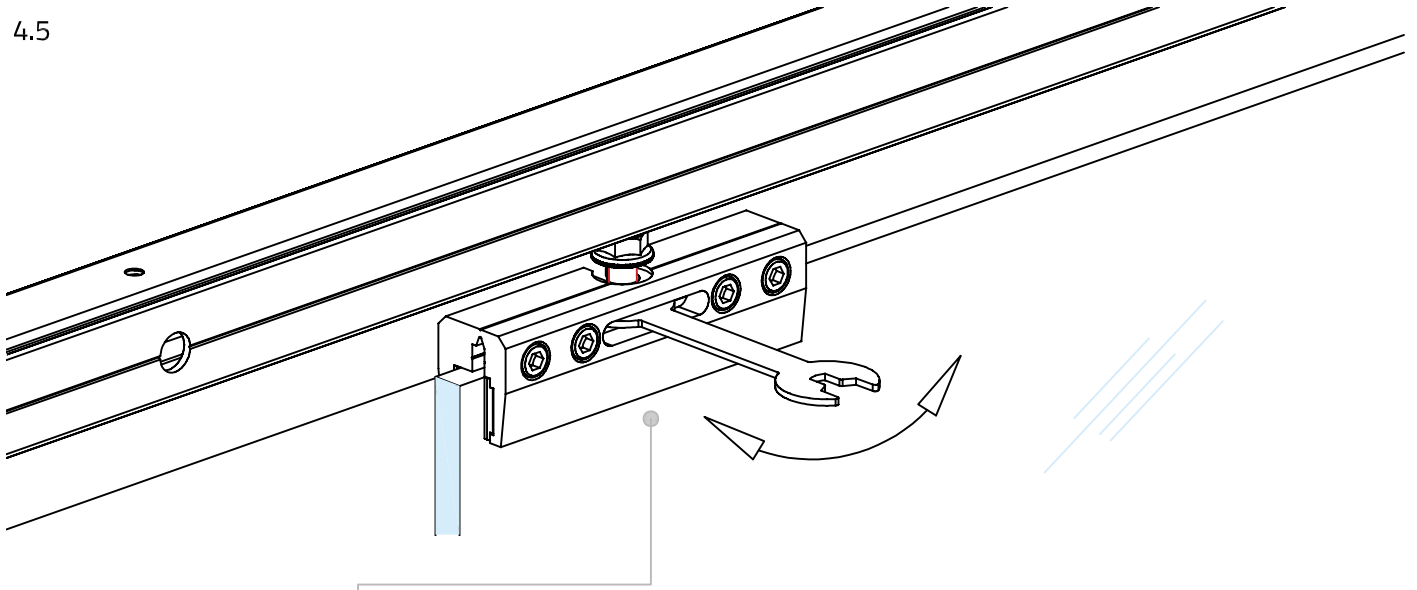

4.6

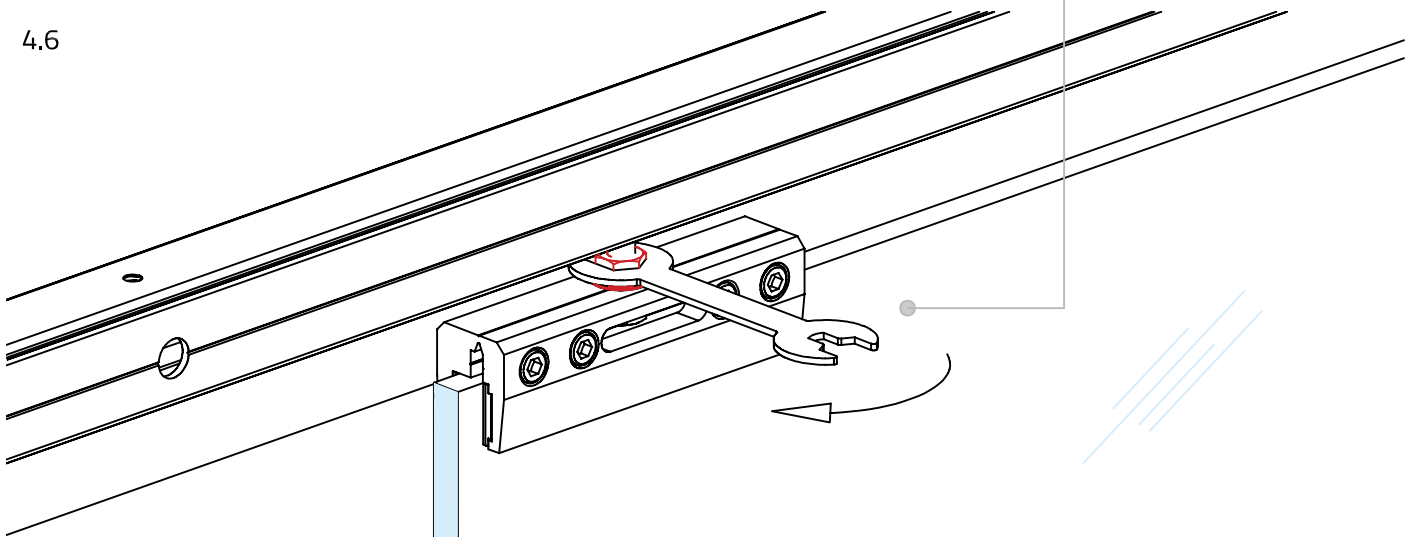

5. Abdeckprofil und Abdeckkappen anbringen

5. Mount cover profile & cover caps

5.1

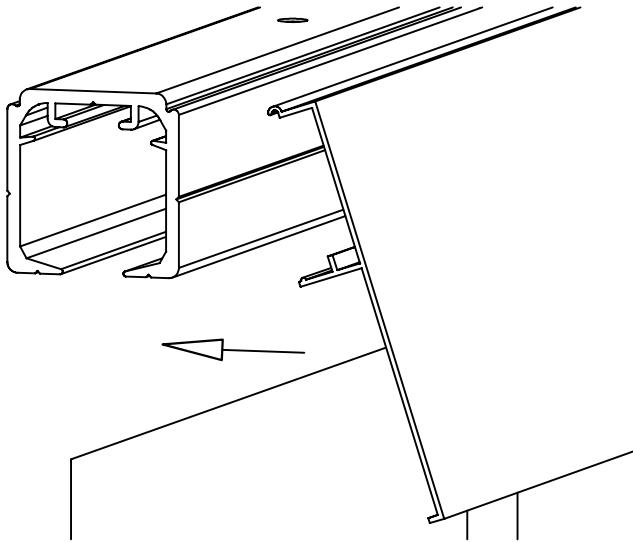

5.2

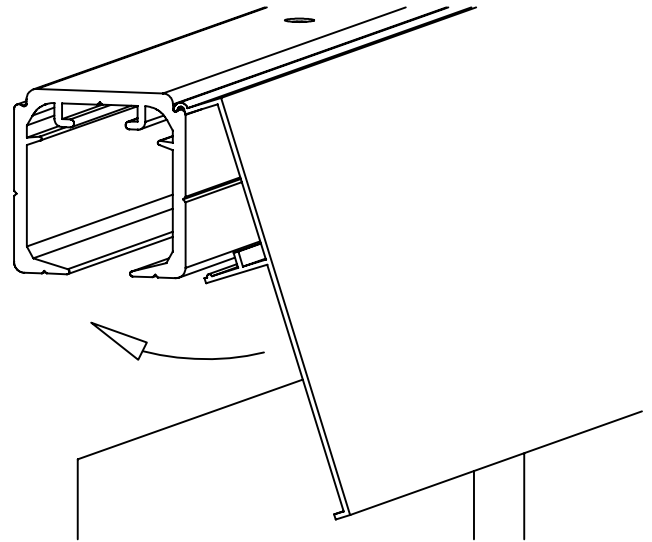

5.3

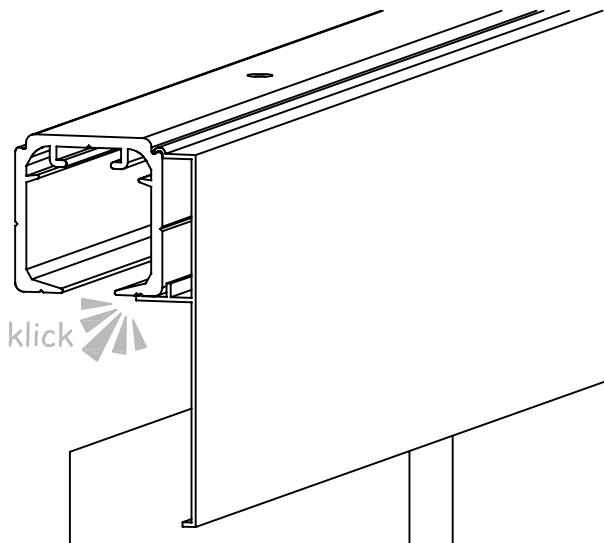

5.4

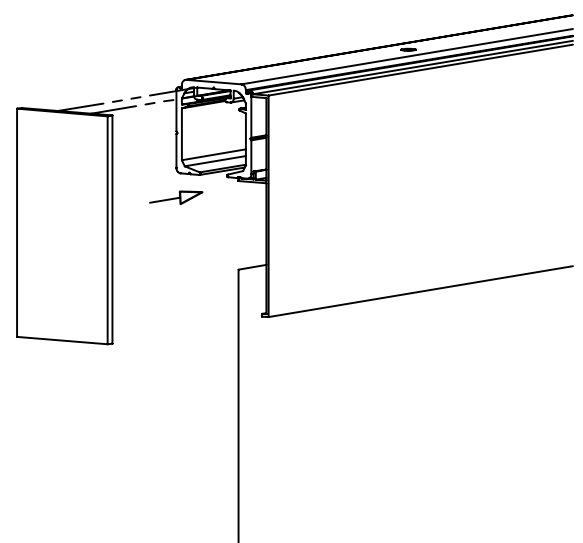

5.5

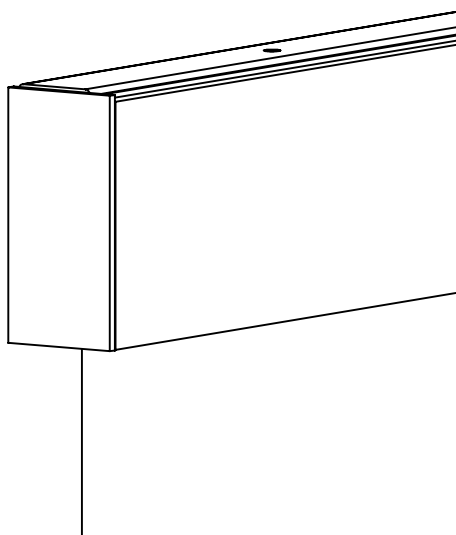

G-FITTINGS GmbH

Marie-Curie-Straße 16-18
46446 Emmerich am Rhein
T +49 (0)2822 962 0
F +49 (0)2822 962 221
E sales@g-fittings.com