

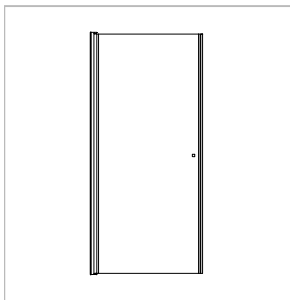

Technische Daten:
Hebe-Senk Dusche (Set) - Nische

Datasheet:
Lift-off shower (set) - niche

Art. 29.4016.001.10
Art. 29.4016.001.26
Art. 29.4016.001.46

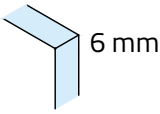
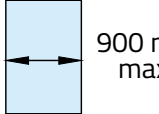

| | | | | |
|--------------------------------|----------------------------------------------------------------------------------------|-----------------------------------------------------------------------------------------------|-----------------------------------------------------------------------------------------------|-----------------------------------------------------------------------------------------------------------------------|
| Ausführung: Options: |  6 mm |  900 mm max. |  25 kg max. |  DIN links/left + DIN rechts/right |
| Material: Material: | Aluminium aluminum | | Gewicht: / Weight: 4,42 kg | |
| Oberflächen: Finish: | silber matt eloxiert silver matt anodised | Chrom-Design Chrome design | Anthrazit-Design Anthracite design | |

Im Lieferumfang enthalten:
Scope of supply:

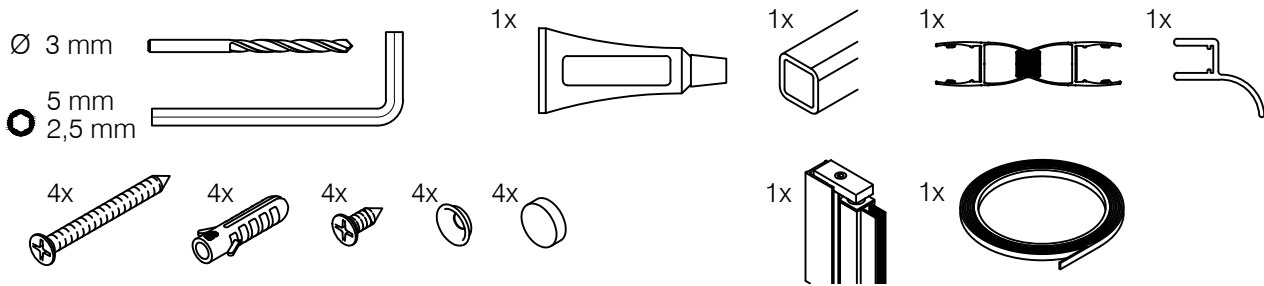

Montagewerkzeug:
Mounting tools:

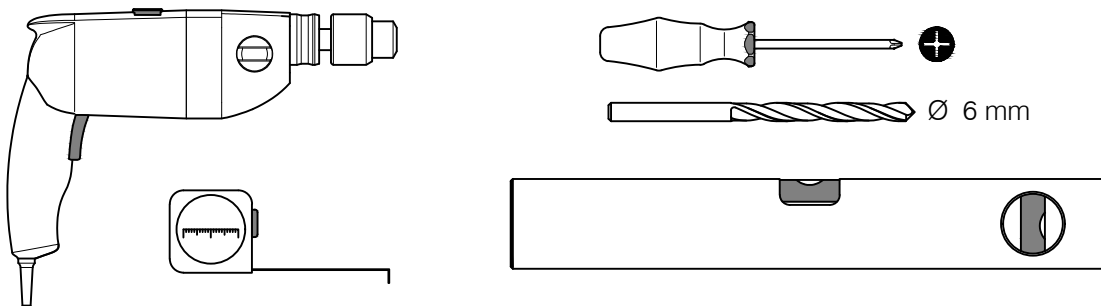

Art. 29.4016.001.10
Art. 29.4016.001.26
Art. 29.4016.001.46

Stand 10.2021

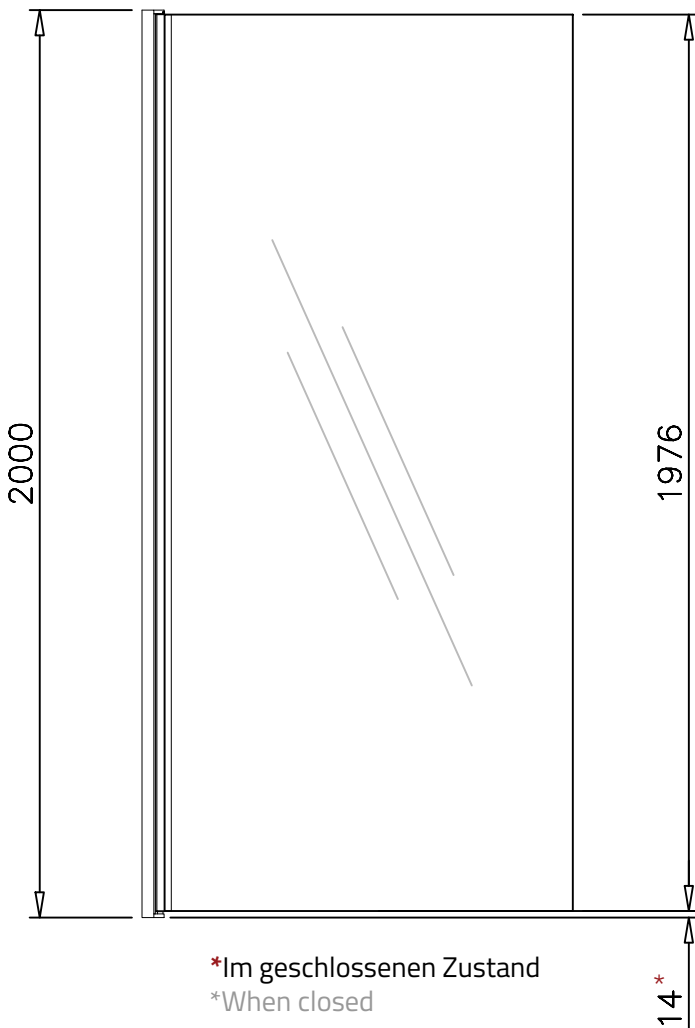
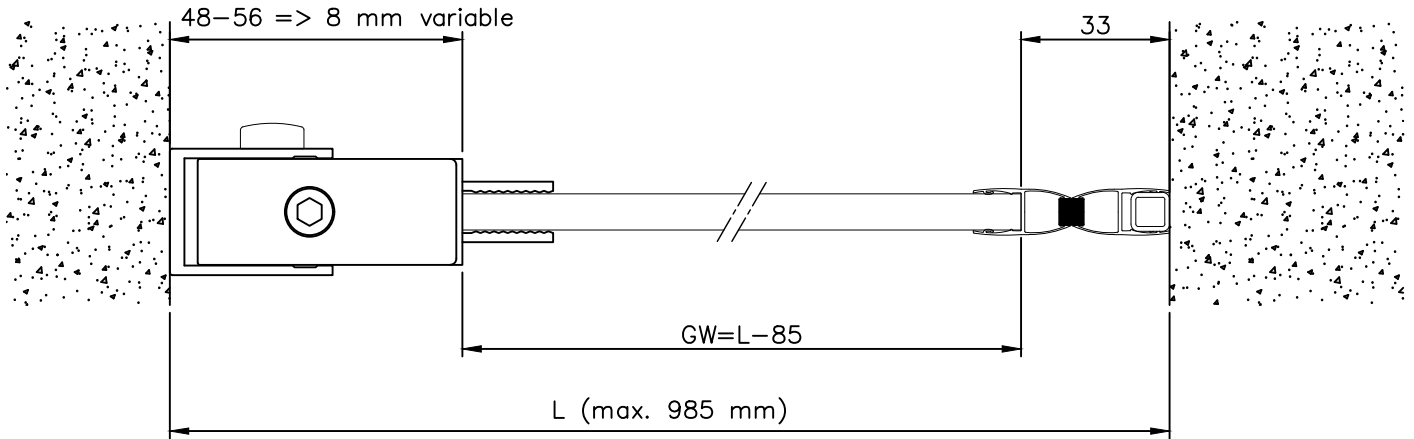

G-FITTINGS GmbH

Marie-Curie-Straße 16-18
46446 Emmerich am Rhein
T +49 (0)2822 962 0
F +49 (0)2822 962 221
E sales@g-fittings.com

Art. 29.4016.001.10
Art. 29.4016.001.26
Art. 29.4016.001.46

Stand 10.2021

1. Montage des Wandprofils:
1. Mounting of the wall profile:

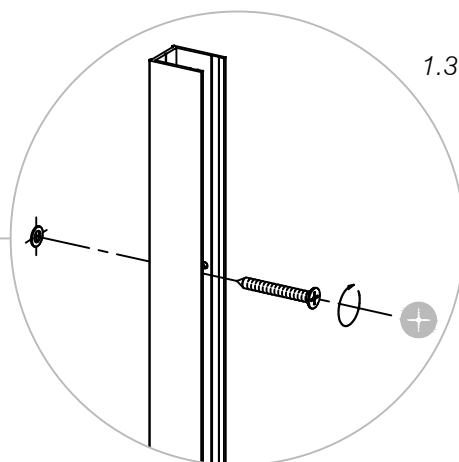
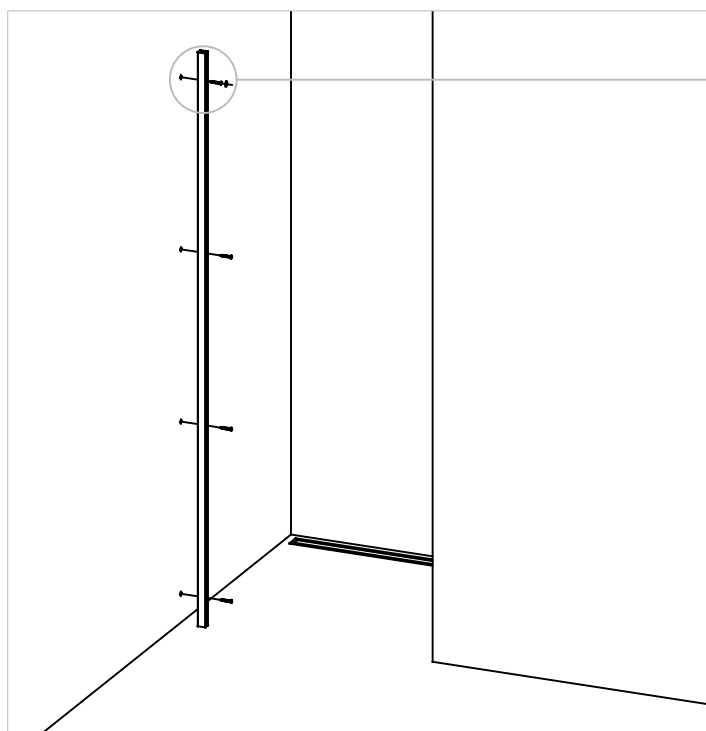
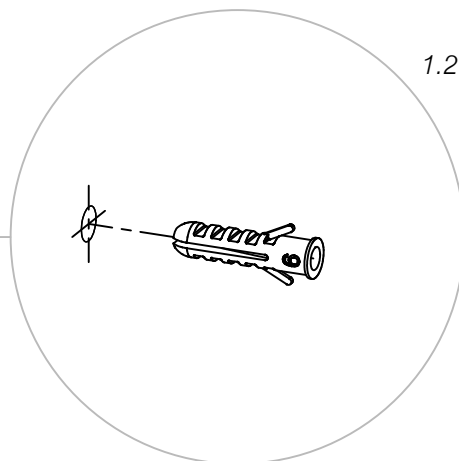
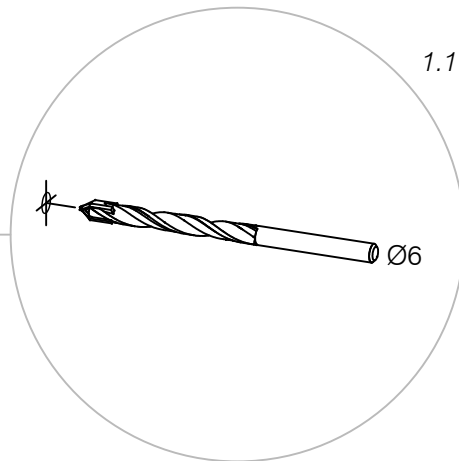
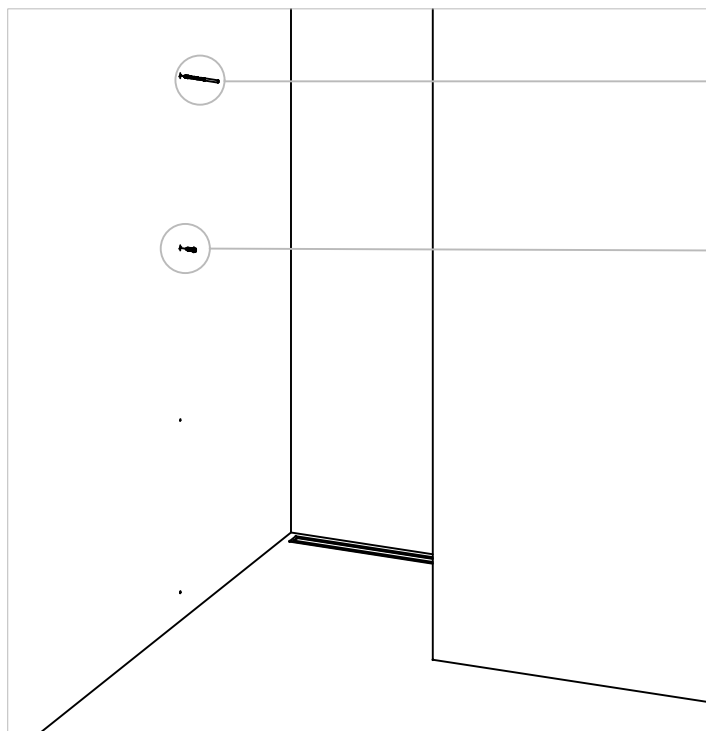

Art. 29.4016.001.10
Art. 29.4016.001.26
Art. 29.4016.001.46

Stand 10.2021

2. Montage des Türprofils an die Türscheibe:
2. Mounting the door profile to the door glass:

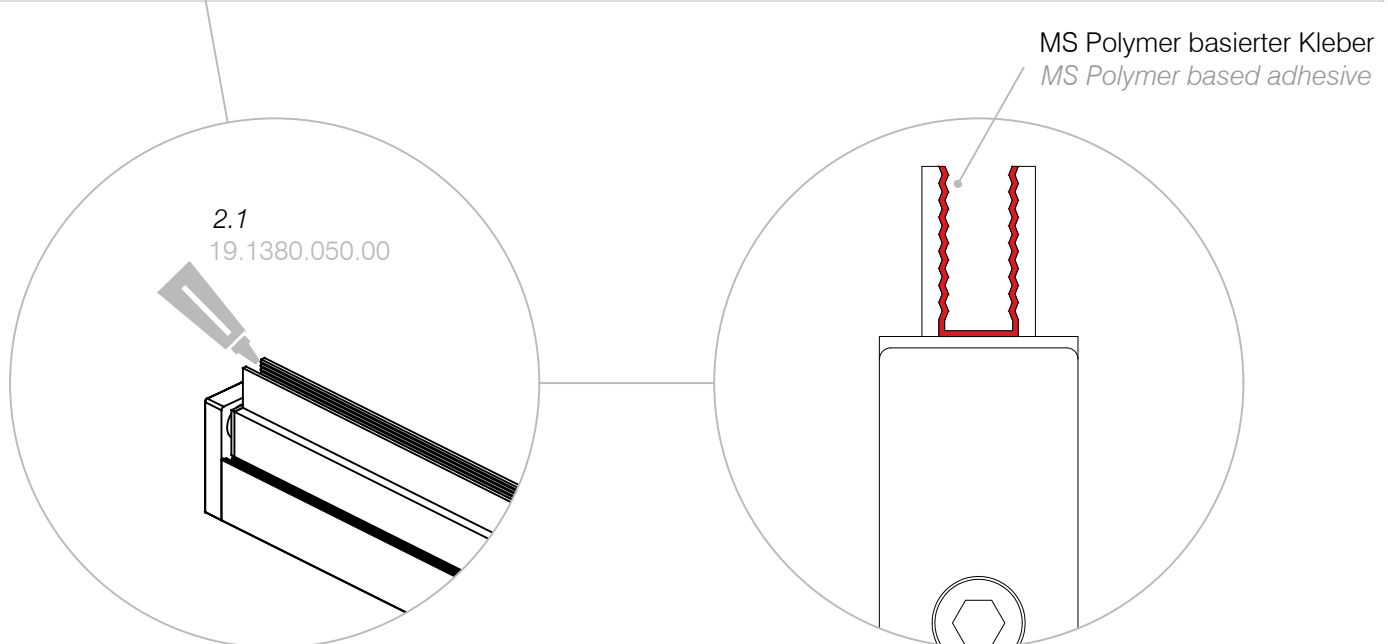
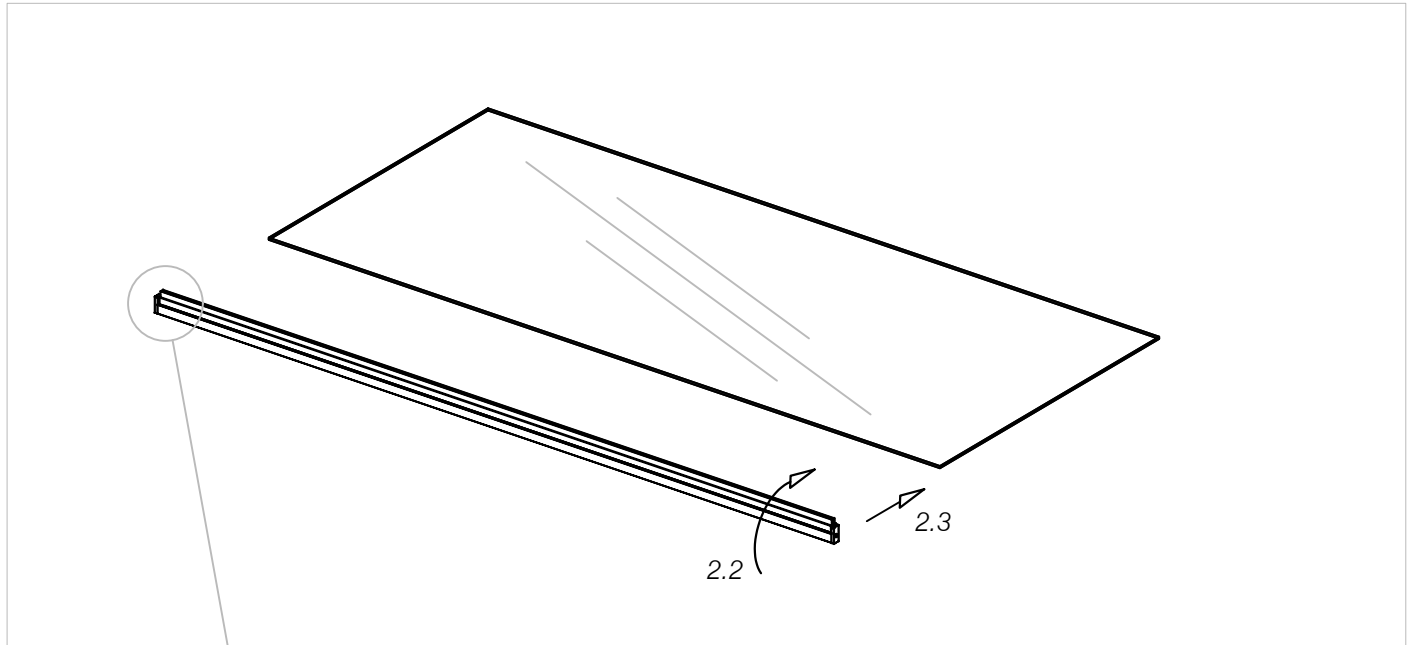

Wichtig: Vor der Montage das Glas im Bereich der Klebefläche reinigen.
Wir empfehlen G-Fittings Glasreiniger art. 91.1800.000.00

Important: Before mounting, clean the glass in the area of the bonding surface.
We recommend G-Fittings glass cleaner art. 91.1800.000.00

Art. 29.4016.001.10
 Art. 29.4016.001.26
 Art. 29.4016.001.46

3. Montage der Glastüre:
 3. Mounting the glass door:

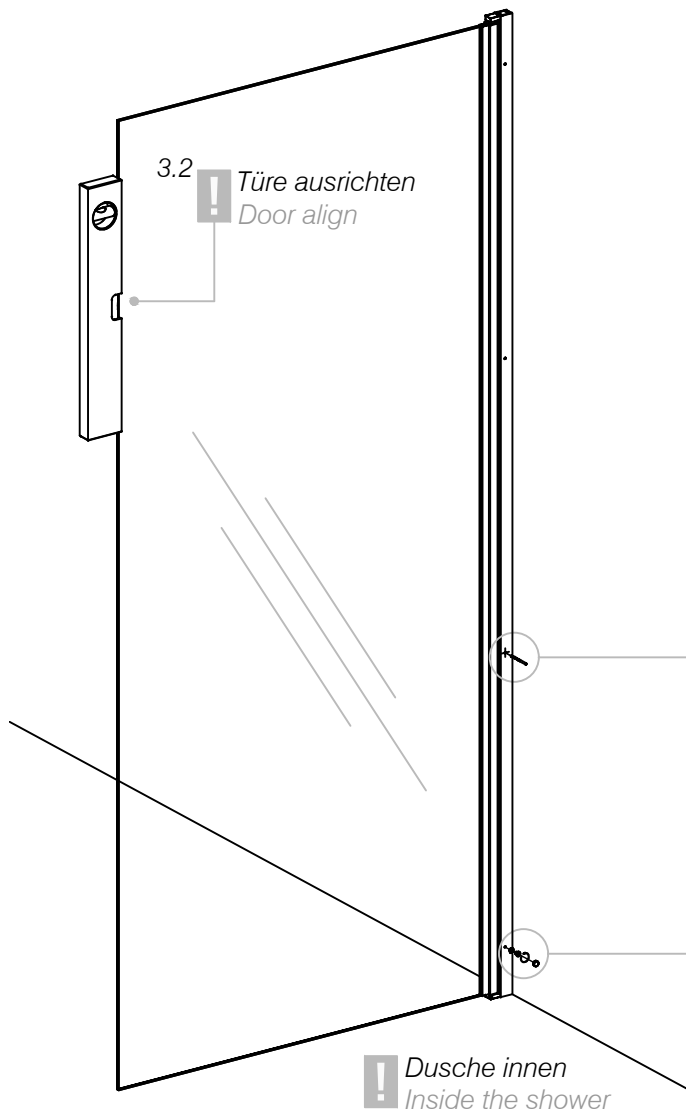
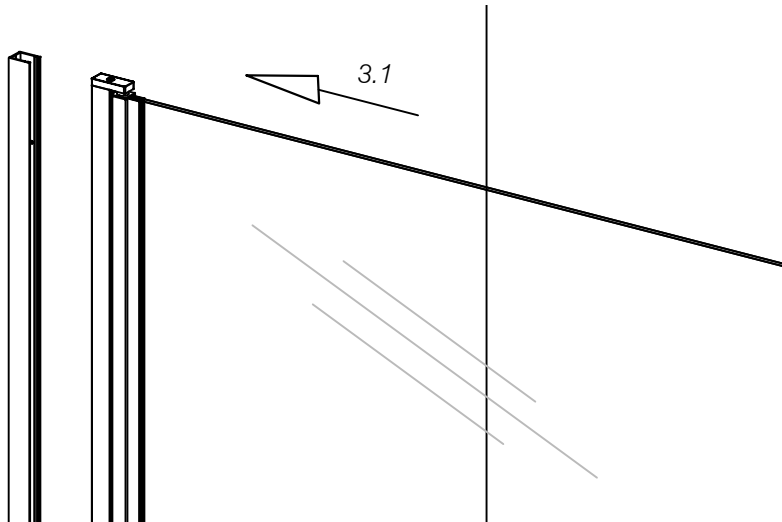

- 3.3 **!** Bohrungen auf das Scharnierprofil übertragen & zusammenschrauben.
- 3.4 Drill holes transferred to the hinge profile and screw it together.

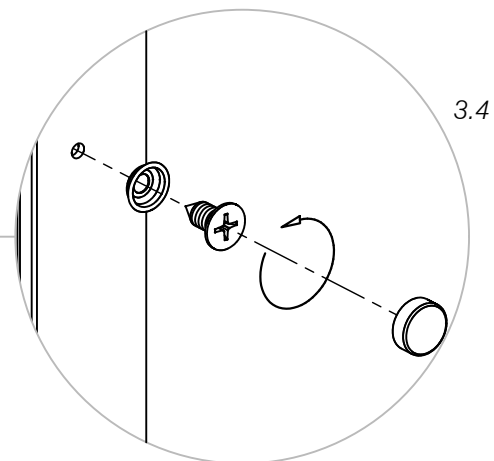
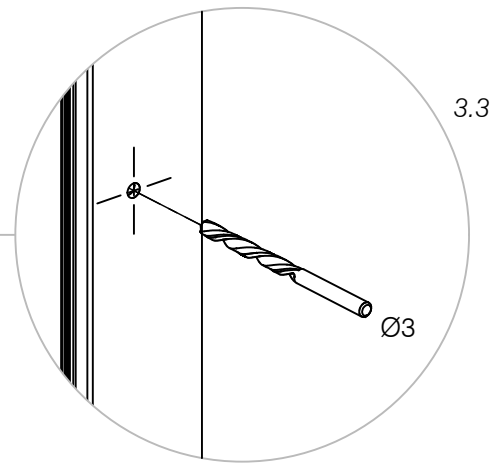

Art. 29.4016.001.10
 Art. 29.4016.001.26
 Art. 29.4016.001.46

4. Einstellen der 0° Stellung der Türe:

4. Setting the 0° position of the door:

Draufsicht
 Top view

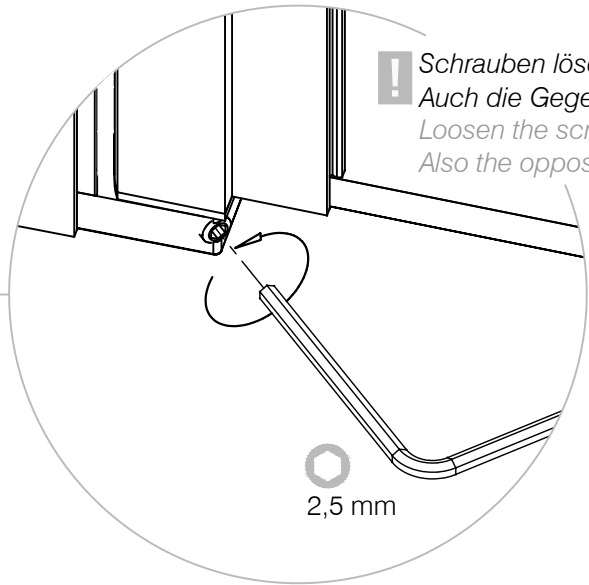
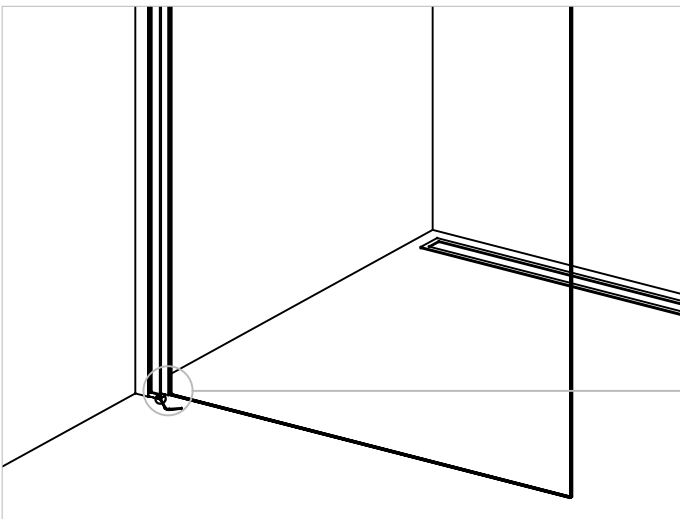
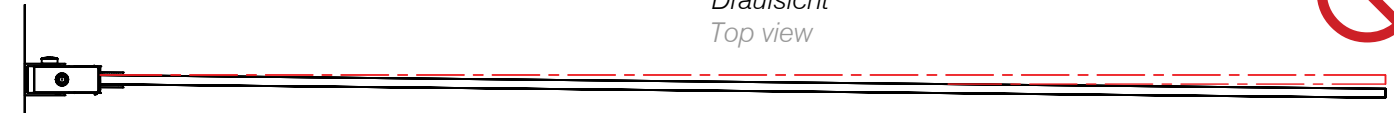

! Schrauben lösen.
 Auch die Gegenseite
 Loosen the screws.
 Also the opposite side

2,5 mm

Draufsicht
 Top view

! Ausrichten
 Adjust

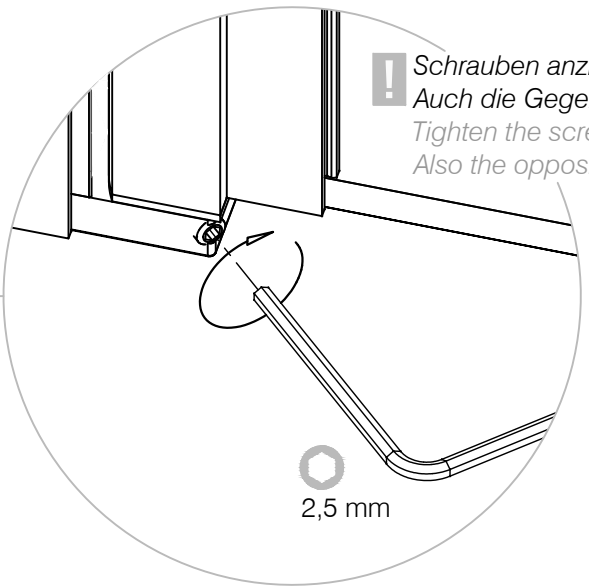
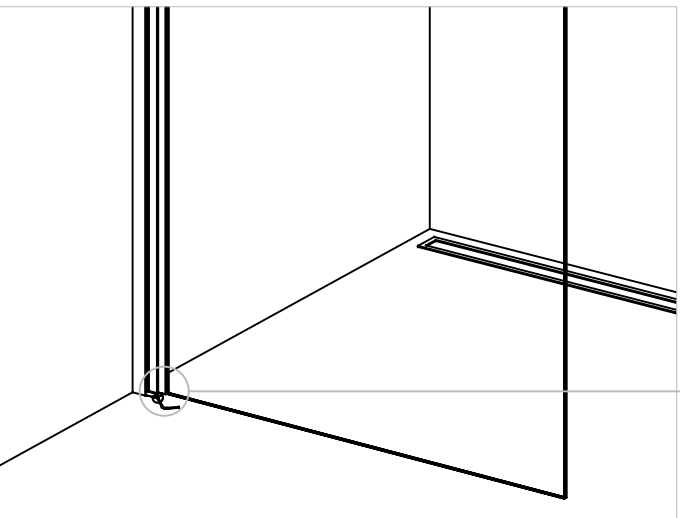

! Schrauben anziehen.
 Auch die Gegenseite
 Tighten the screws.
 Also the opposite side

2,5 mm

5. Vierkantröhr kleben und Lippendichtungen anbringen:

5. glue the square tube and apply seals:

