

Technische Daten:  
Oberteil Zapfenaufnahme - Nika

Datasheet:  
Top part pin Holder - Nika

Art. 77450107000-12  
Art. 77450107000-26

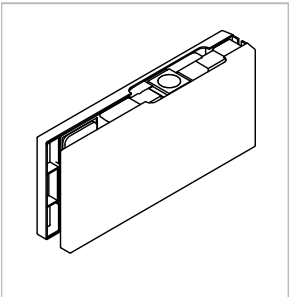

Ausführung:  
Options:

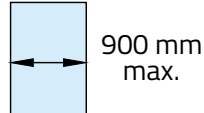
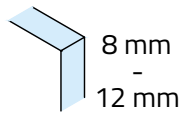

Material:  
Material: Aluminium  
Aluminium

Gewicht: / Weight: 0,6 kg

Oberflächen:  
Finish: Edelstahl-Design  
Stainless steel design

Anthrazit-Design  
Antracite design

Montagewerkzeug und Material (nicht im Lieferumfang erhalten):  
Mounting tools and supply (not included in the scope of delivery):

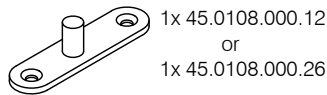

Abmaße:  
Dimensions:

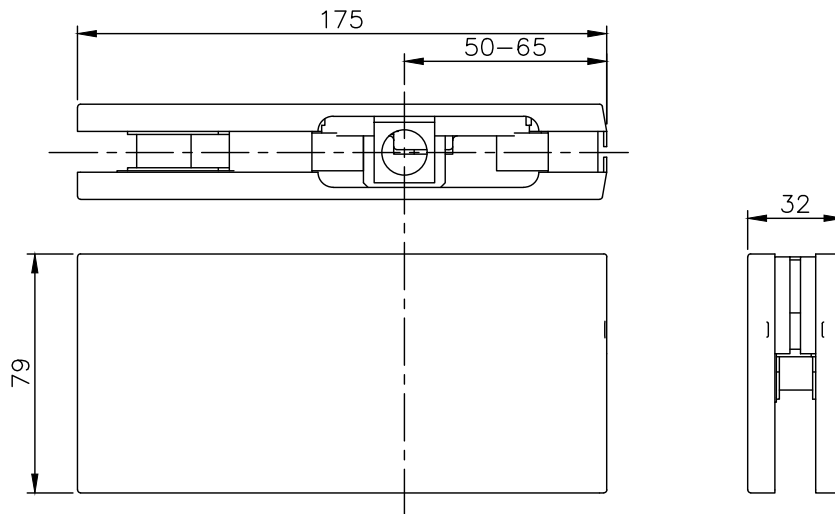

Glasausschnitt:  
Glass cut out:

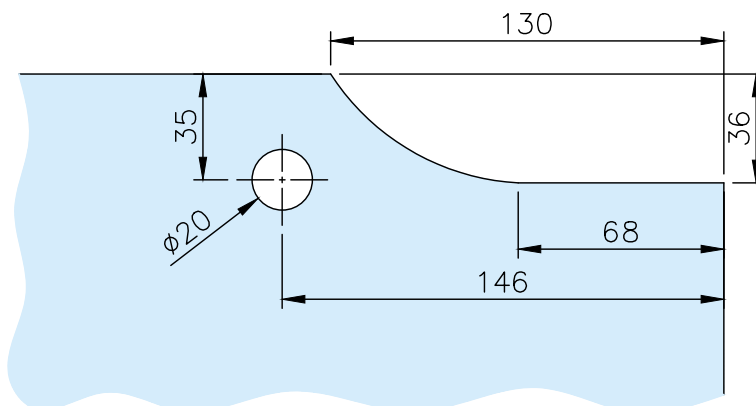

Art. 77450107000-12  
 Art. 77450107000-26

Abmaße  
 Dimensions

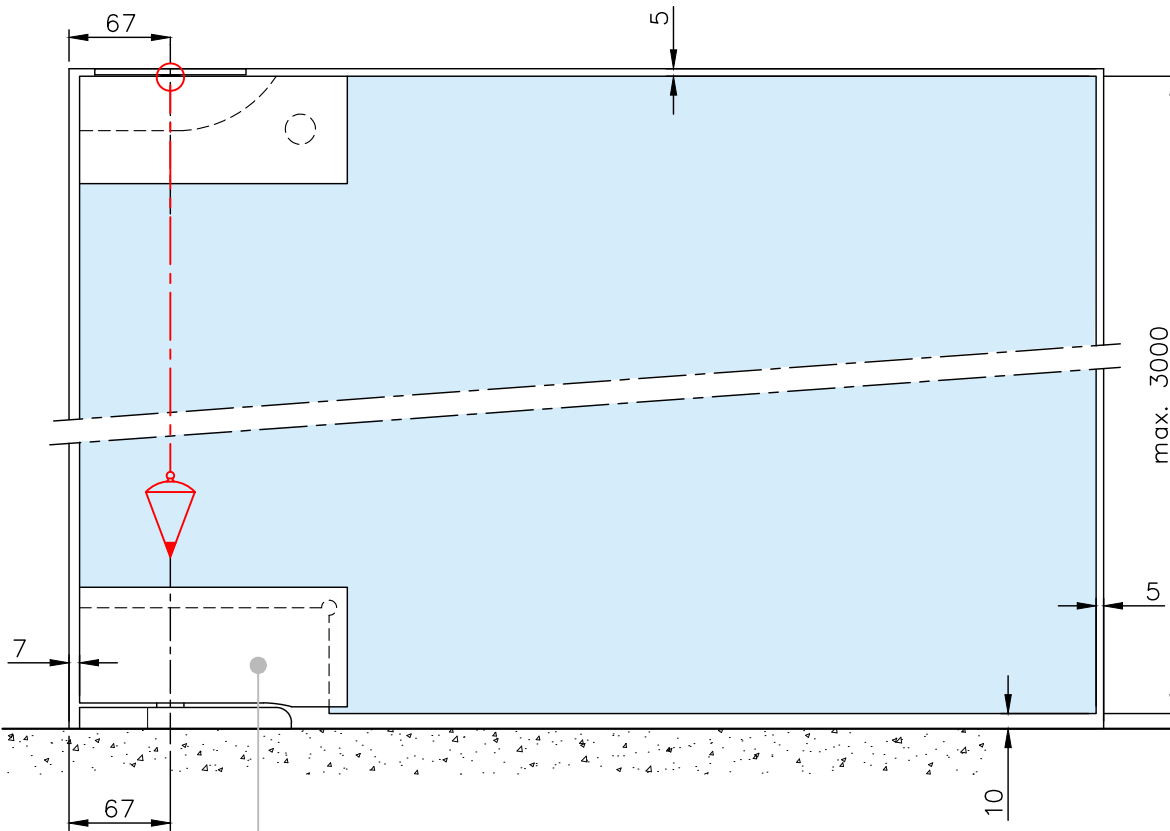

**!** In der Abbildung ist unser Eckbeschlag hydraulisch Levi 45.0106.000.12 dargestellt  
 In the picture is shown our corner fitting hydraulic Levi 45.0106.000.12

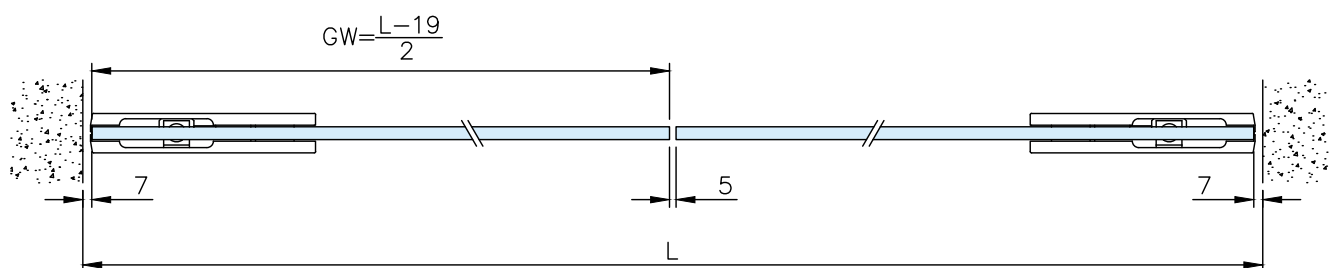
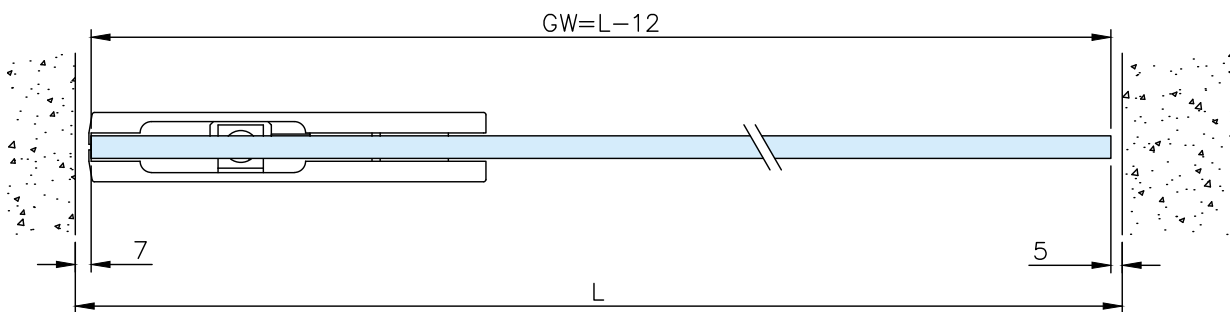

**1. Fitting an das Glas anbringen (Nur 10 - 12 mm Glas)**  
1. Mount fitting to the glass (Only 10 - 12 mm glass)

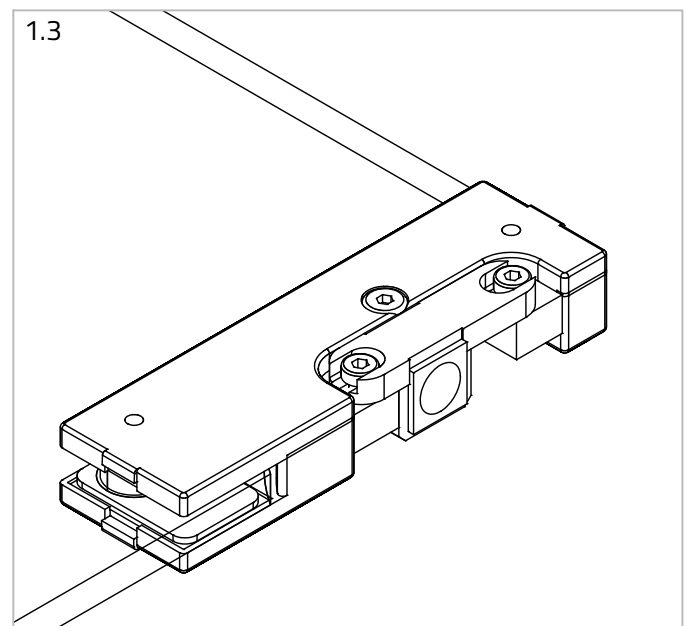
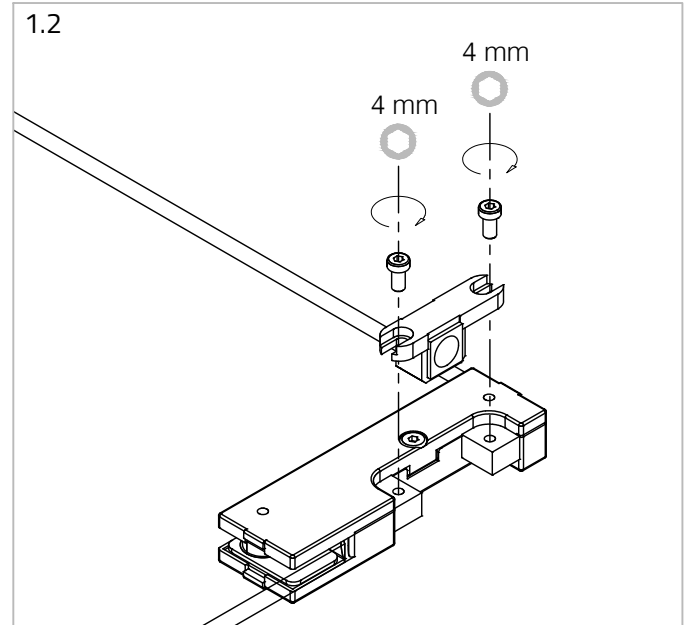
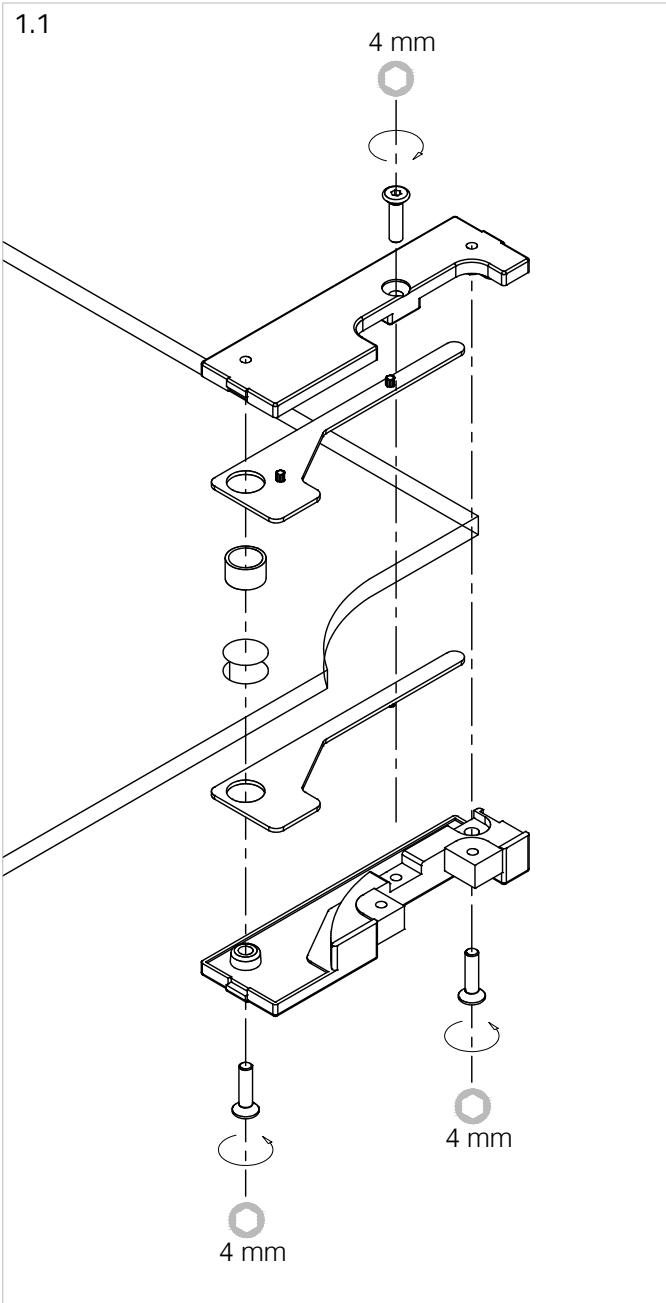

**Wichtig:** Vor der Montage das Glas im Bereich der Klebefläche reinigen.  
Wir empfehlen **G-Fittings** Glasreiniger art. **779118000000**

**Important:** Before mounting, clean the glass in the area of the bonding surface.  
We recommend **G-Fittings** glass cleaner art. **779118000000**

Art. 77450107000-12  
Art. 77450107000-26

1. Vorbereiten und Fitting an das Glas anbringen **(Nur 8 mm Glas)**  
1. Prepare and mount fitting to the glass **(Only 8 mm glass)**

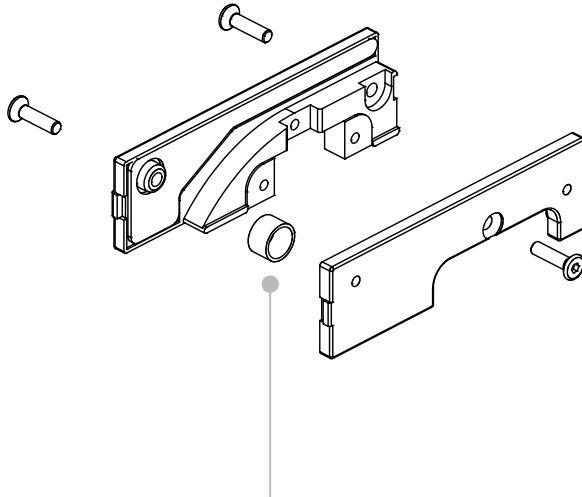

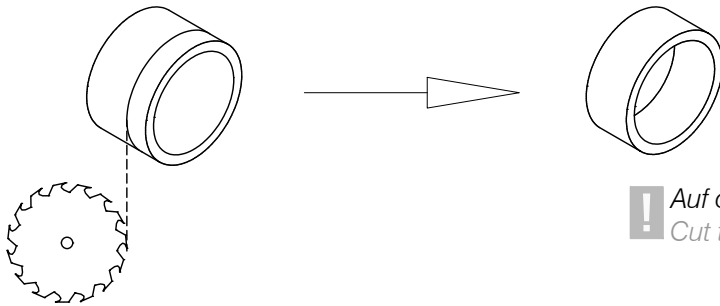

1.1

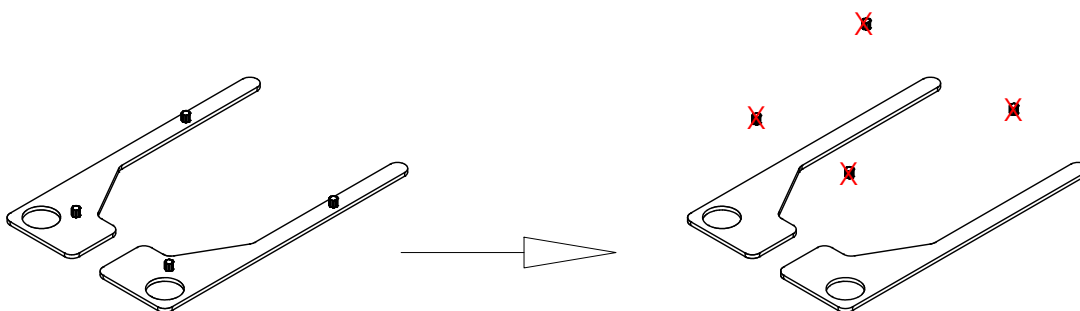

 Auf ca. 7,5 mm zuschneiden  
Cut to approx. 7.5 mm

1.2



 Gummi Pinne nur bei den zusätzlichen Gummipaar abschneiden  
Cut rubber tiller only at the additional rubber pair

**(Nur 8 mm Glas)**  
**(Only 8 mm glass)**

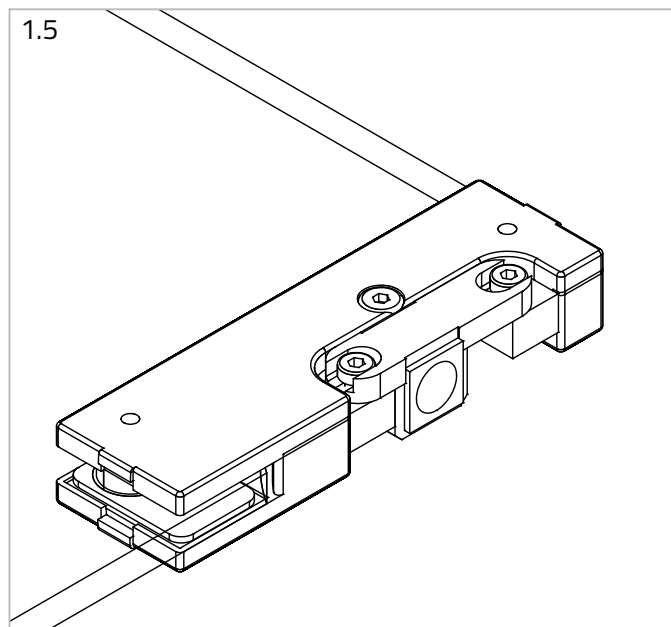
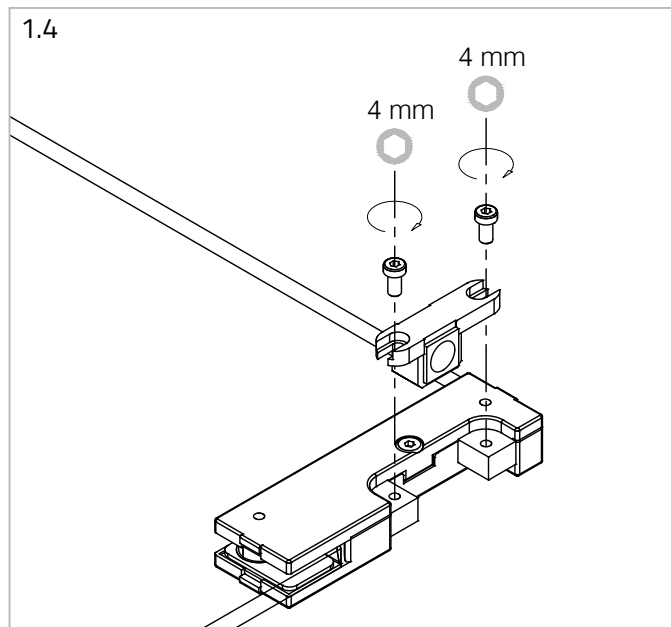
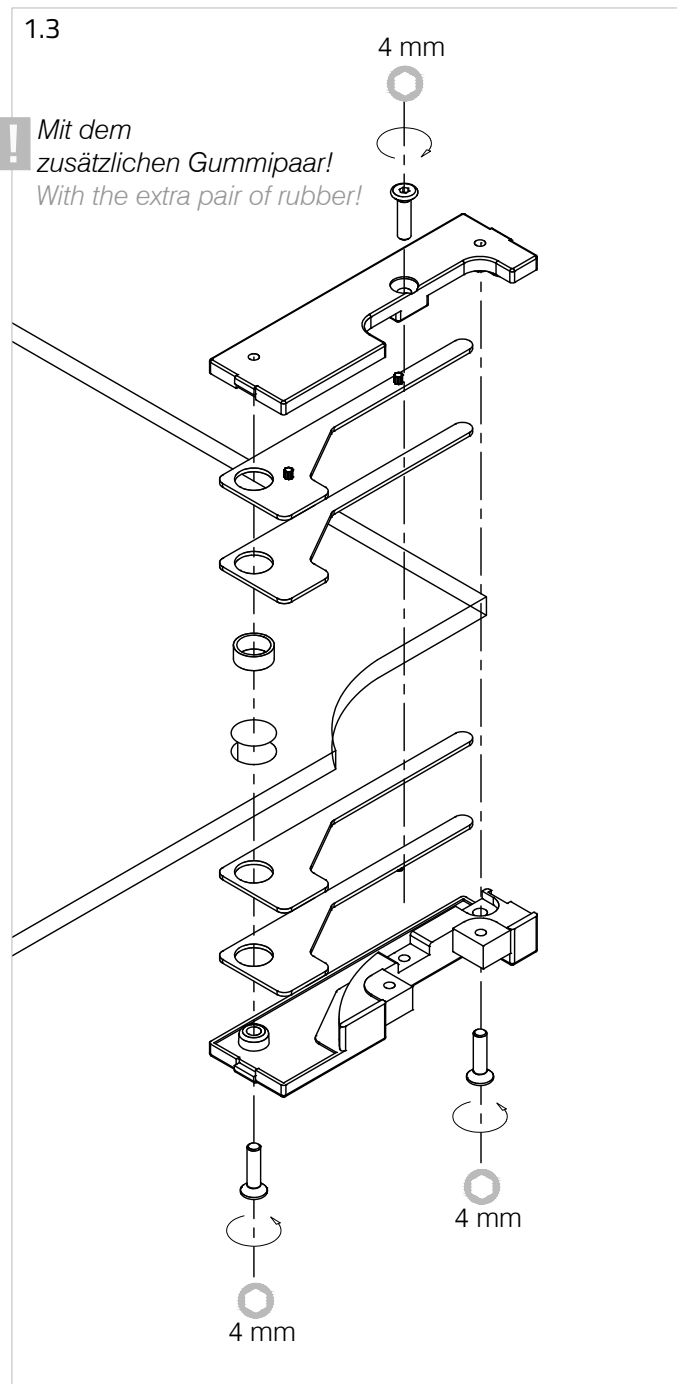

**Wichtig:** Vor der Montage das Glas im Bereich der Klemmfläche reinigen.  
Wir empfehlen G-Fittings Glasreiniger art. 91.1800.000.00

**Important:** Before mounting, clean the glass in the area of the clamp surface.  
We recommend G-Fittings glass cleaner art. 91.1800.000.00

2. Tür Montage und die Einstellung  
2. Door mounting and the setting

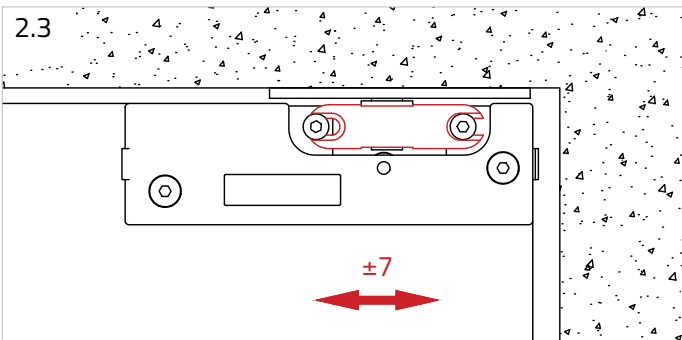
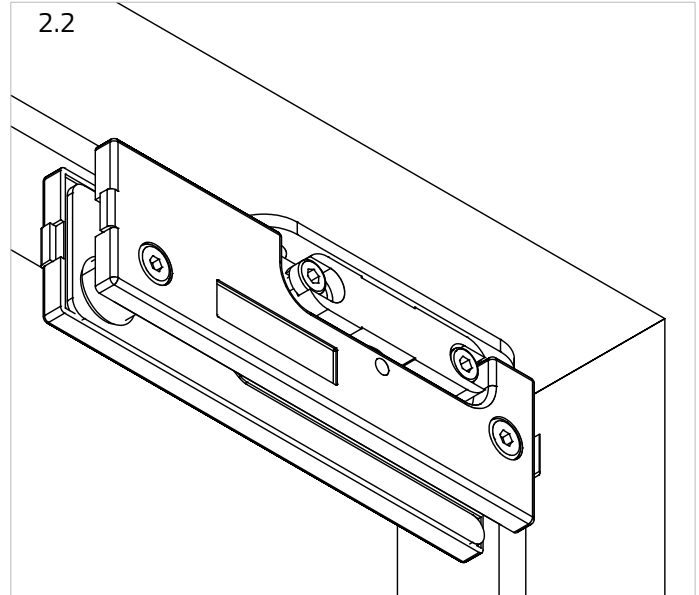
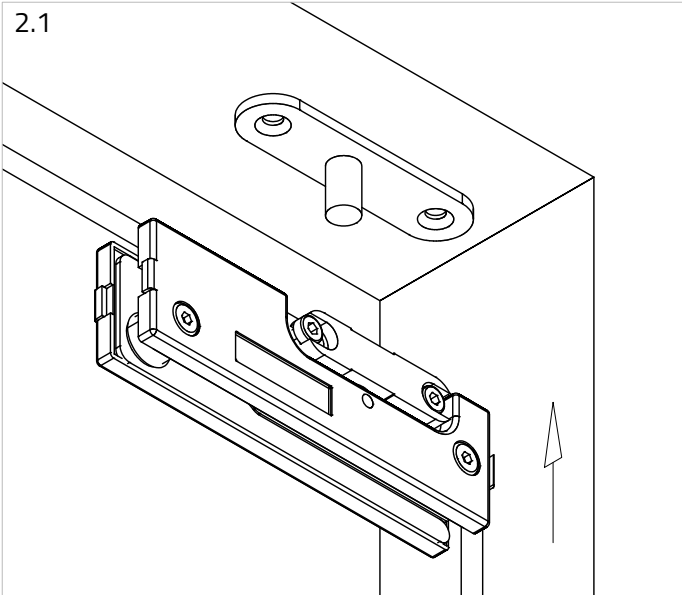

**G-FITTINGS GmbH**

Marie-Curie-Straße 16-18  
46446 Emmerich am Rhein  
T +49 (0)2822 962 0  
E sales@g-fittings.com

