

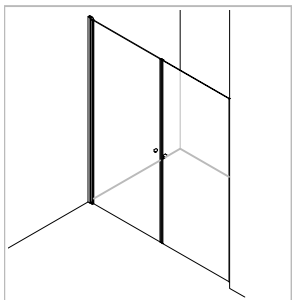



Glass door systems

Technische Daten:
Hebe-Senk Dusche (Set) - Nische (2 Türen)

Datasheet:
Lift-off shower (set) - niche (2 doors)

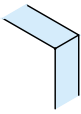
Art. 29.4016.006.10
Art. 29.4016.006.26
Art. 29.4016.006.46

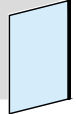

Ausführung: Options:	 6 mm	 900 mm max.	 25 kg max.	 DIN links/left +  DIN rechts/right
	Material: Material:	Aluminium aluminum		Gewicht: / Weight: 5,5 kg
	Oberflächen: Finish:	silber matt eloxiert silver matt anodised	Chrom-Design Chrome design	Anthrazit-Design Anthracite design

Im Lieferumfang enthalten:
Scope of supply:

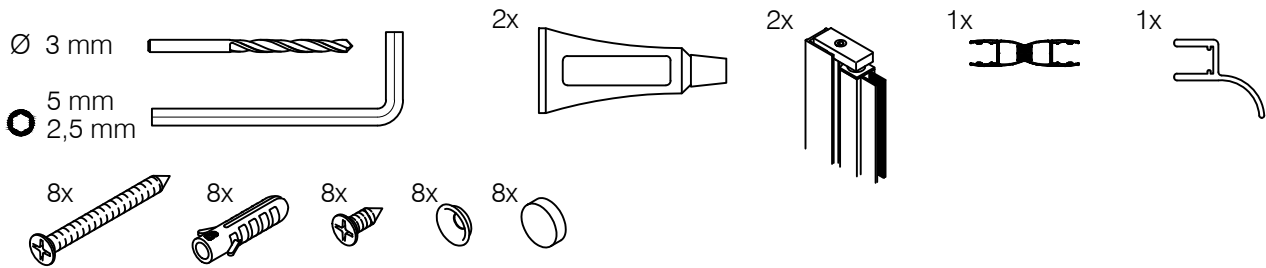

Montagewerkzeug:
Mounting tools:

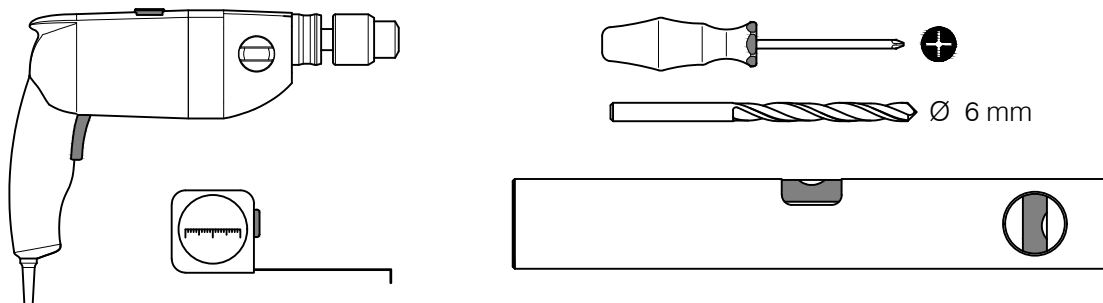

Art. 29.4016.006.10
 Art. 29.4016.006.26
 Art. 29.4016.006.46

Stand 10.2021



G-FITTINGS GmbH

Marie-Curie-Straße 16-18
 46446 Emmerich am Rhein
 T +49 (0)2822 962 0
 F +49 (0)2822 962 221
 E sales@g-fittings.com

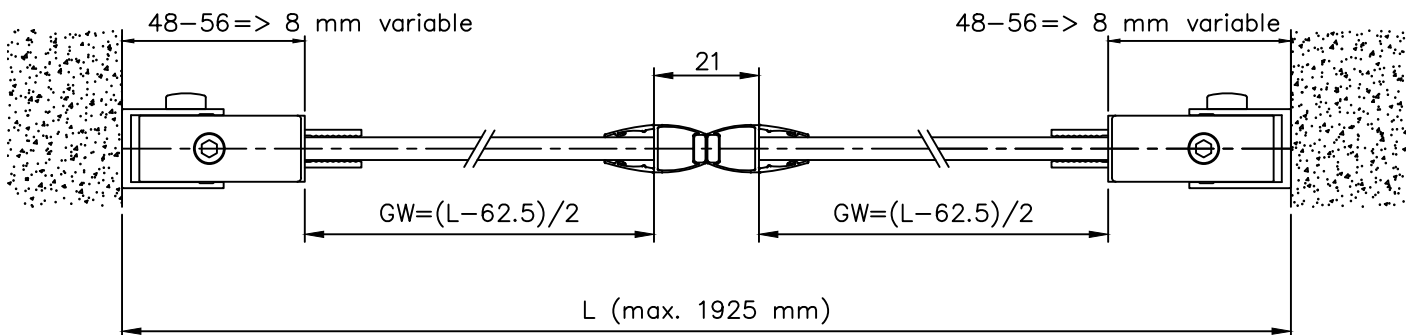

1. Montage des Wandprofils:
 1. Mounting of the wall profile:

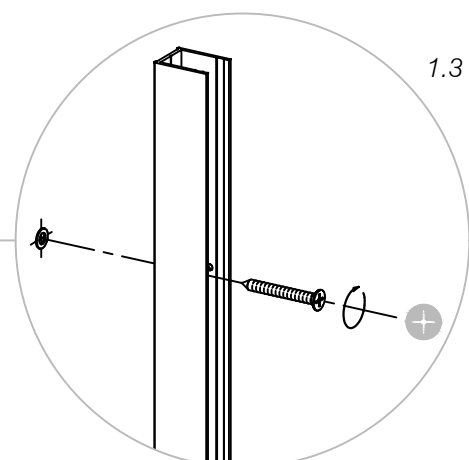
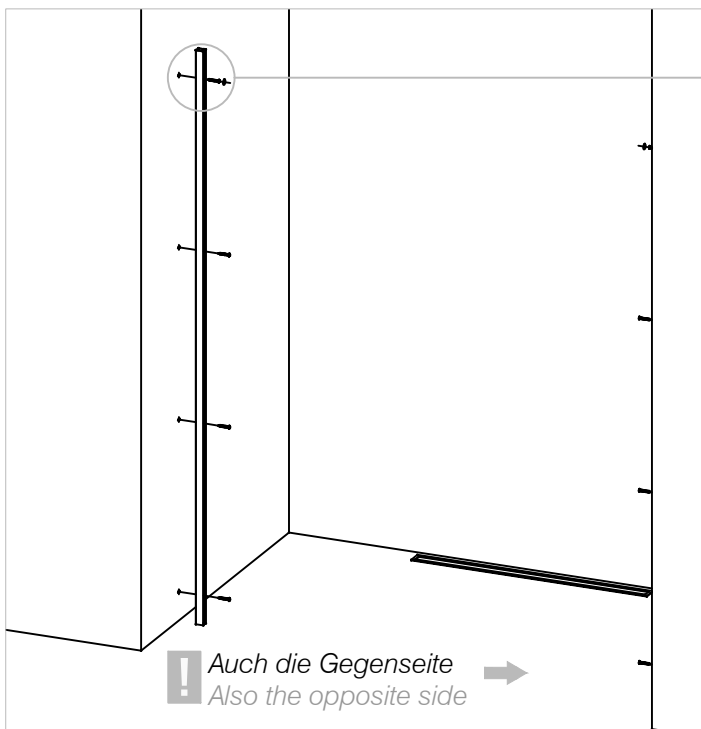
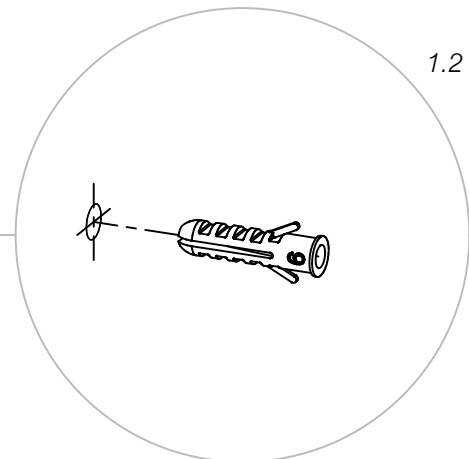
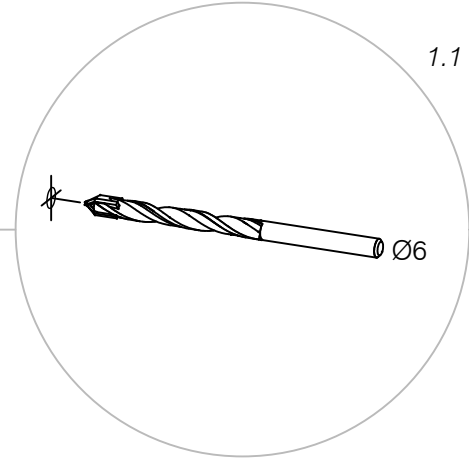
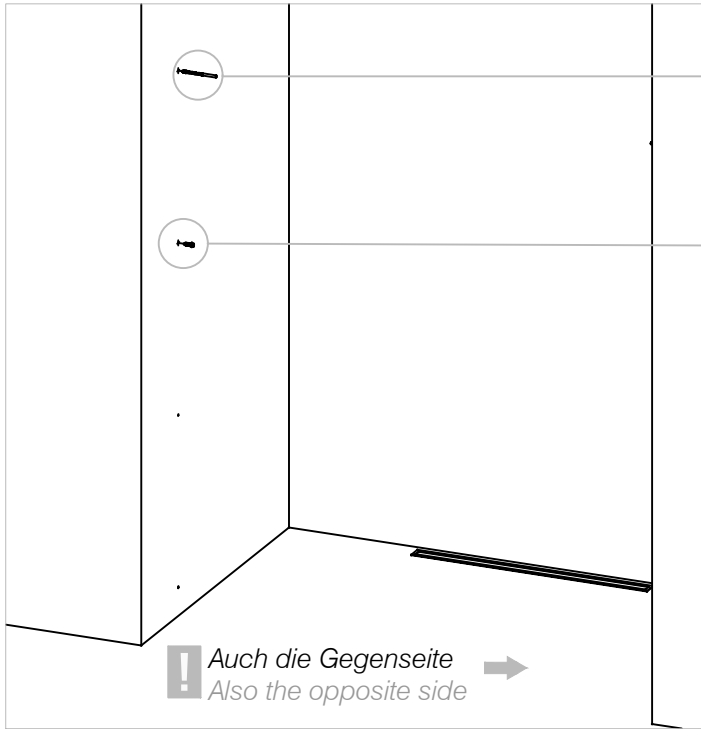

Art. 29.4016.006.10
Art. 29.4016.006.26
Art. 29.4016.006.46

Stand: 10.2021

2. Montage des Türprofils an die Türscheibe:
2. Mounting the door profile to the door glass:

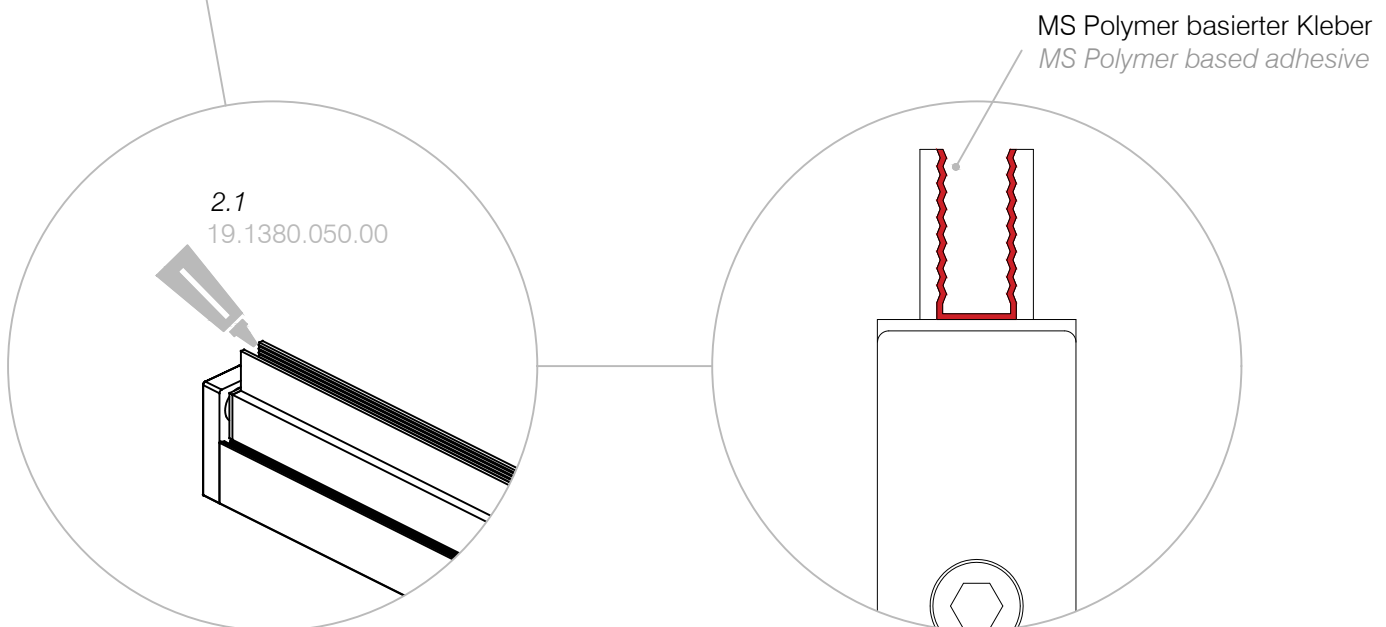
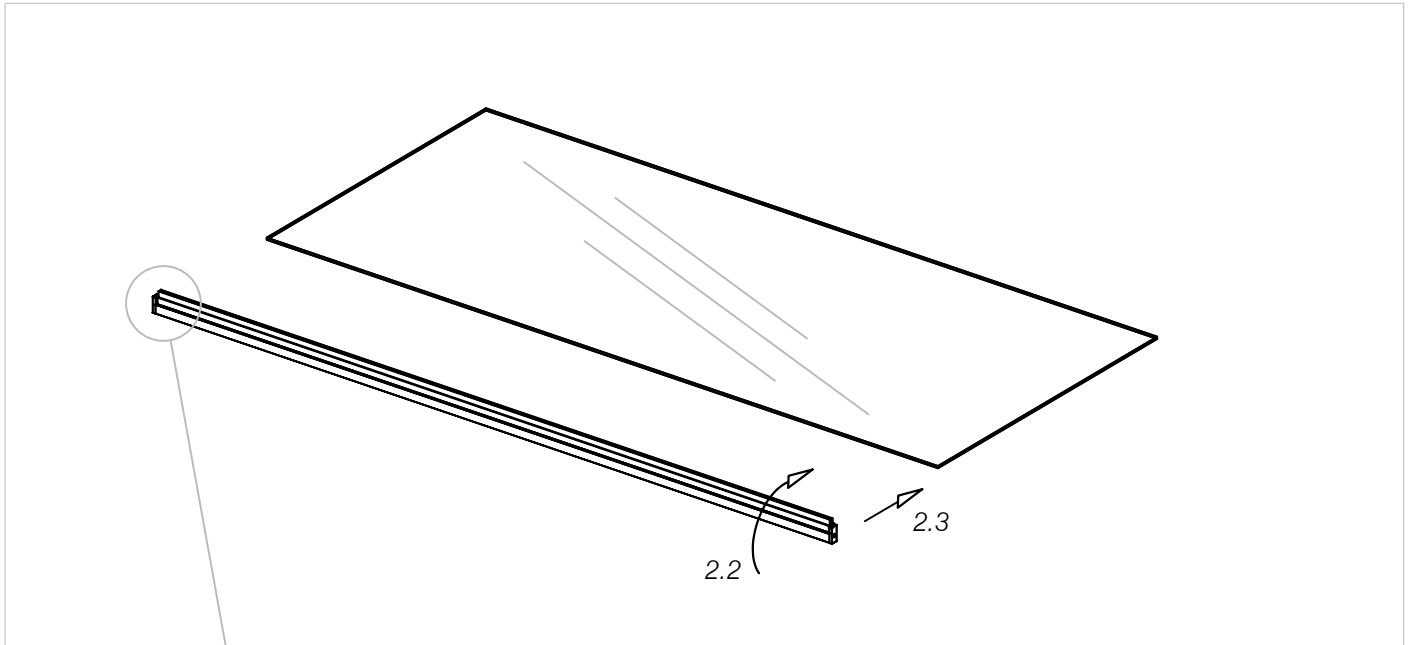

Wichtig: Vor der Montage das Glas im Bereich der Klebefläche reinigen.
Wir empfehlen G-Fittings Glasreiniger art. 91.1800.000.00

Important: Before mounting, clean the glass in the area of the bonding surface.
We recommend G-Fittings glass cleaner art. 91.1800.000.00

3. Montage der Glastüre:
 3. Mounting the glass door:

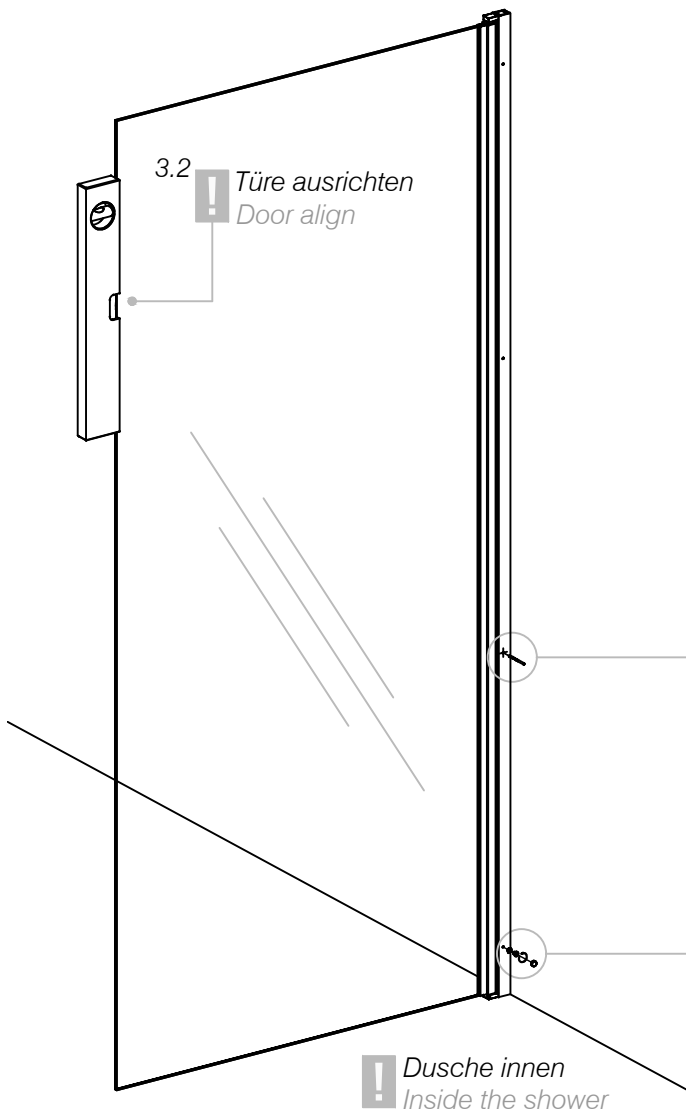
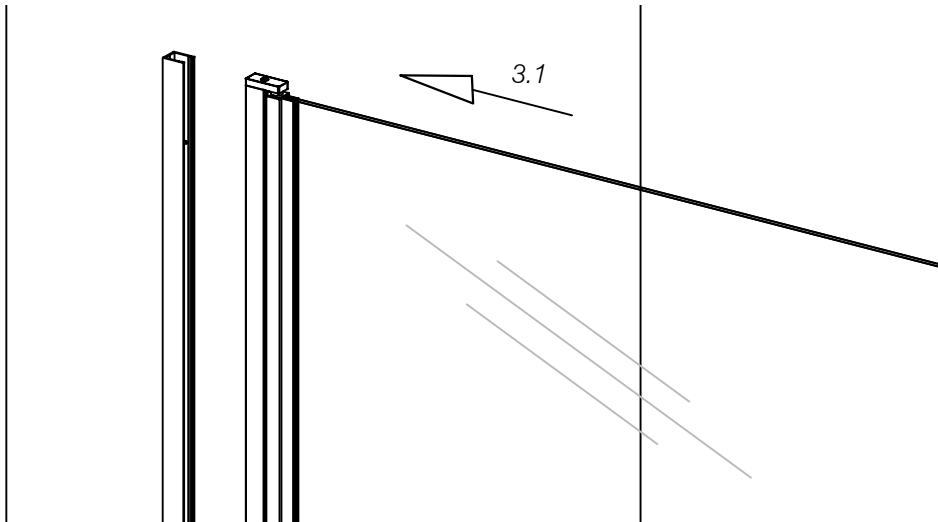

- 3.3  Bohrungen auf das Scharnierprofil übertragen & zusammenschrauben.
- 3.4 Drill holes transferred to the hinge profile and screw it together.

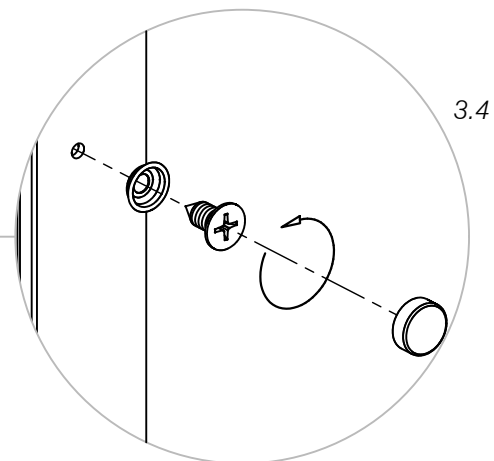
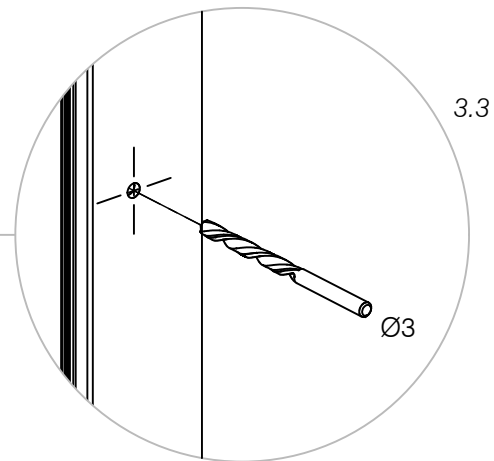

Art. 29.4016.006.10
 Art. 29.4016.006.26
 Art. 29.4016.006.46

4. Einstellen der 0° Stellung der Türe:

4. Setting the 0° position of the door:

Draufsicht
 Top view

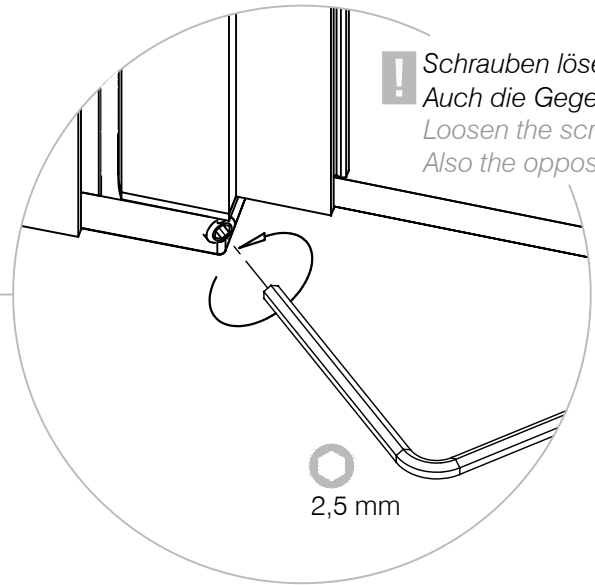
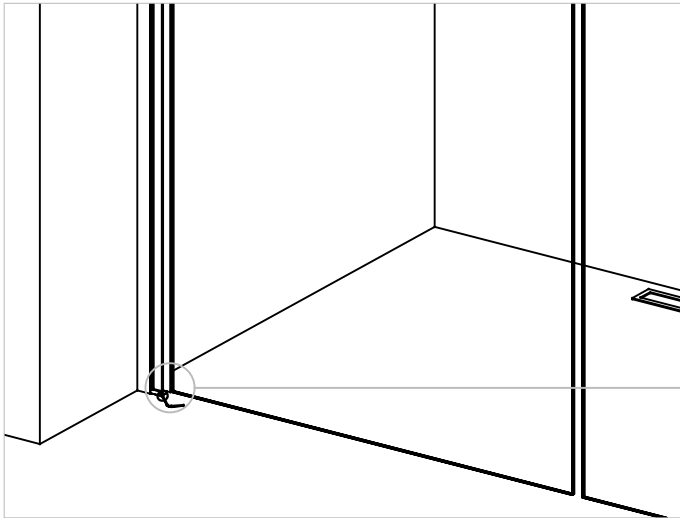

! Schrauben lösen.
 Auch die Gegenseite
 Loosen the screws.
 Also the opposite side

2,5 mm

Draufsicht
 Top view

! Ausrichten
 Adjust

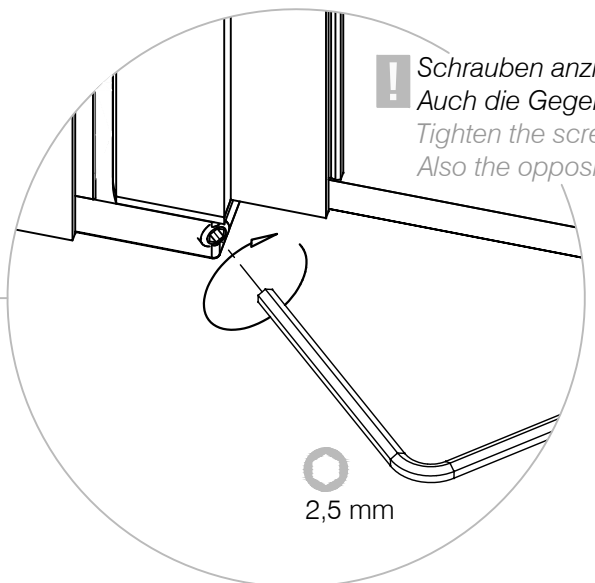
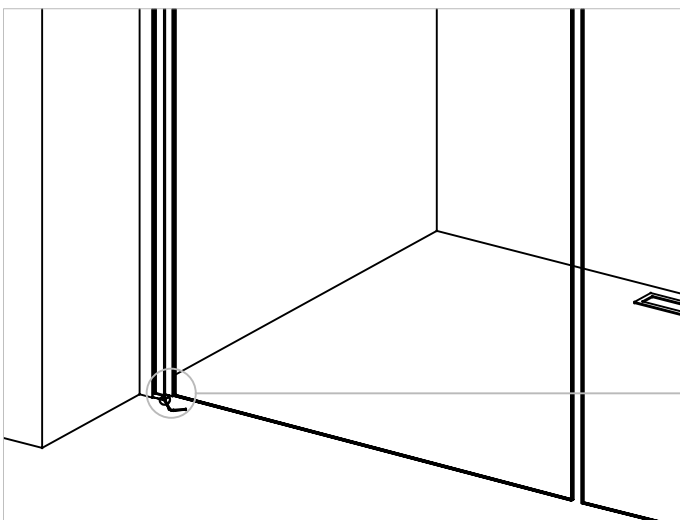
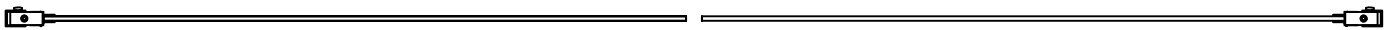

! Schrauben anziehen.
 Auch die Gegenseite
 Tighten the screws.
 Also the opposite side

2,5 mm

Art. 29.4016.006.10
Art. 29.4016.006.26
Art. 29.4016.006.46

5. Lippendichtungen anbringen:

5. Apply seals:

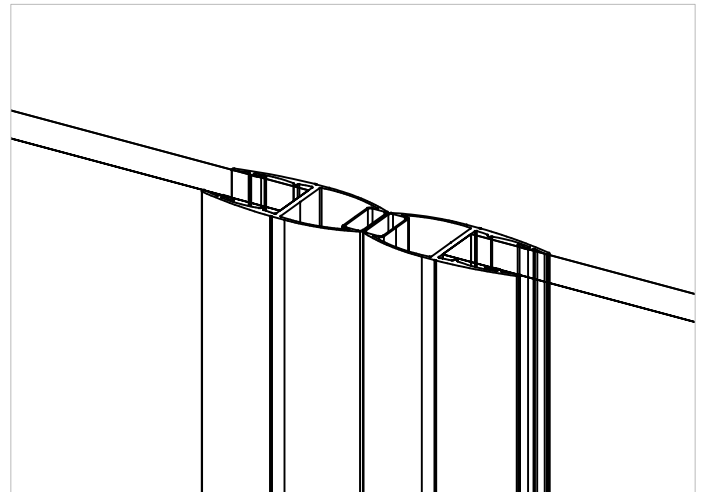
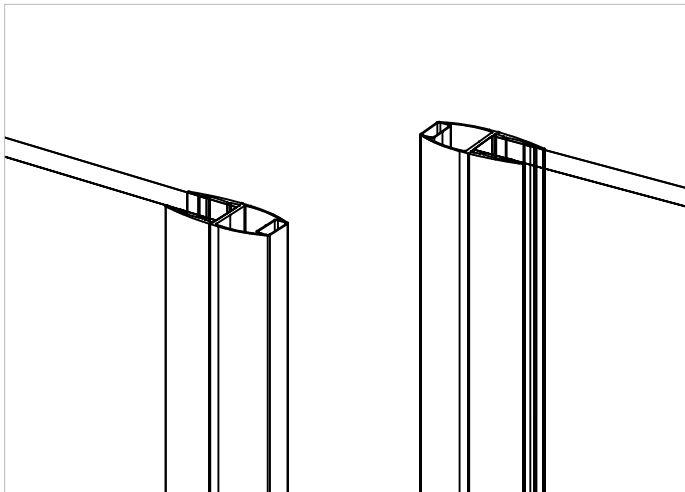
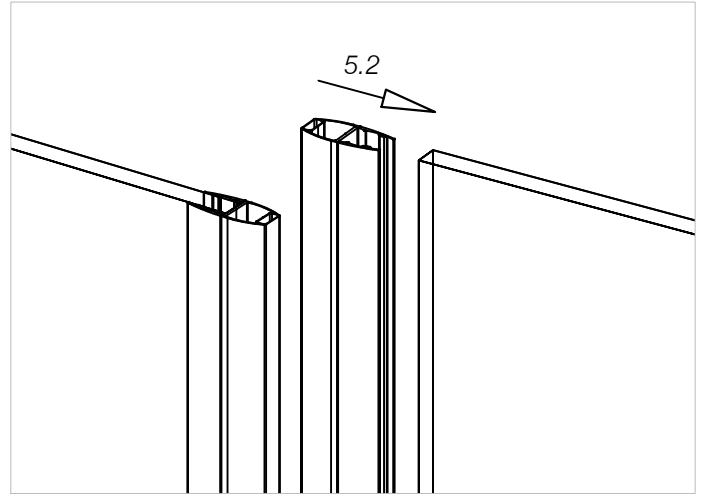
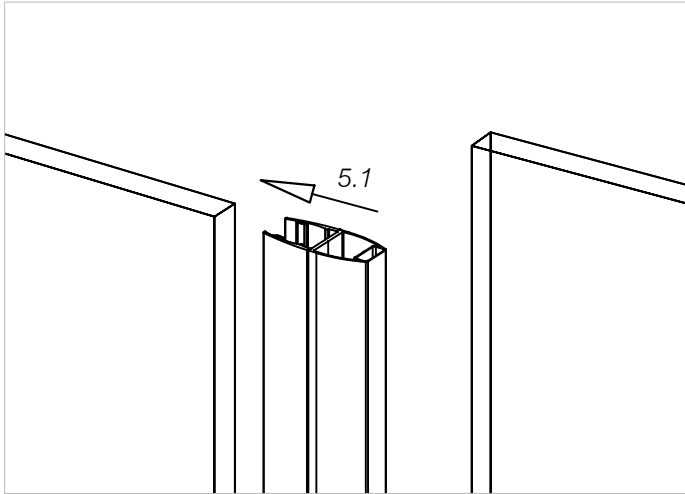

G-FITTINGS GmbH

Marie-Curie-Straße 16-18
46446 Emmerich am Rhein
T +49 (0)2822 962 0
F +49 (0)2822 962 221
E sales@g-fittings.com