

Glass stacking wall - Aleandra

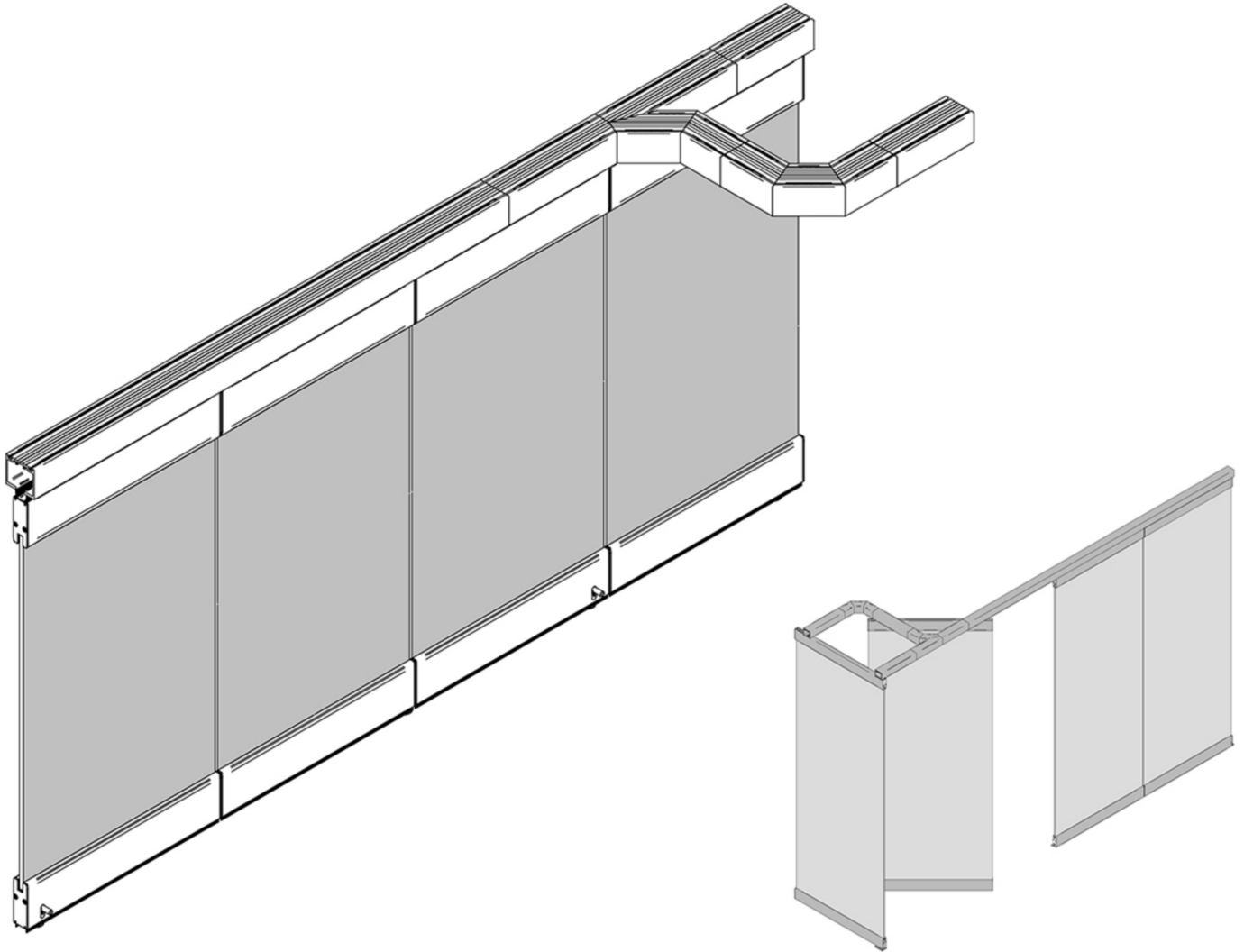

ASSEMBLY INSTRUCTIONS



MAX
150 KG



min. 550
MAX 1200



MAX
3500

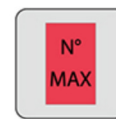

∞



10 - 10,76
12 - 12,76 mm



Required tool

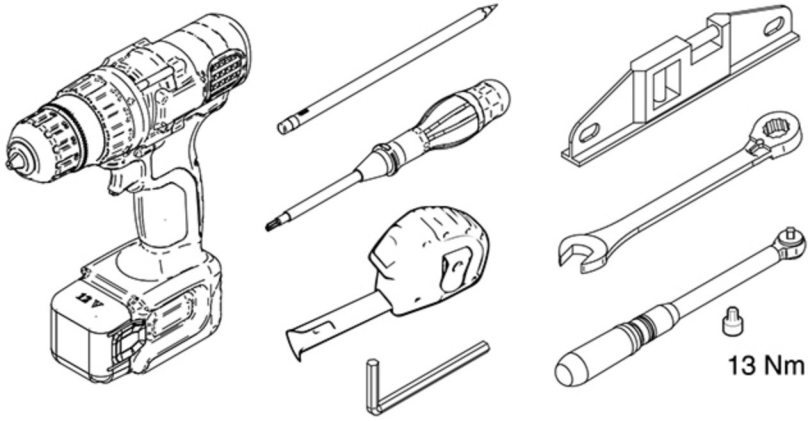

Clean the glass and profile before installing

We recommend our Glass cleaner Hendrika 7791180100000

Components

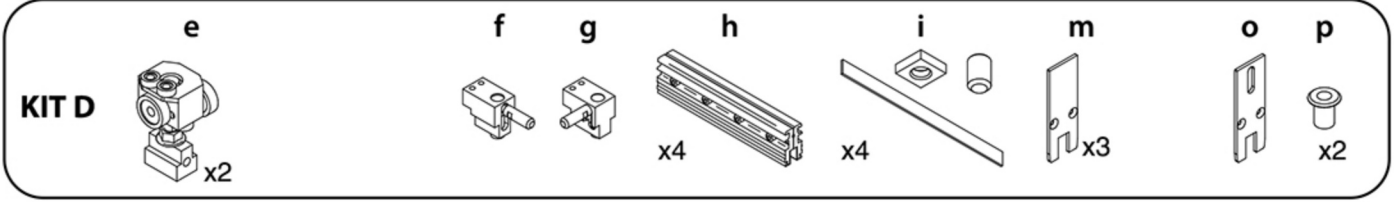
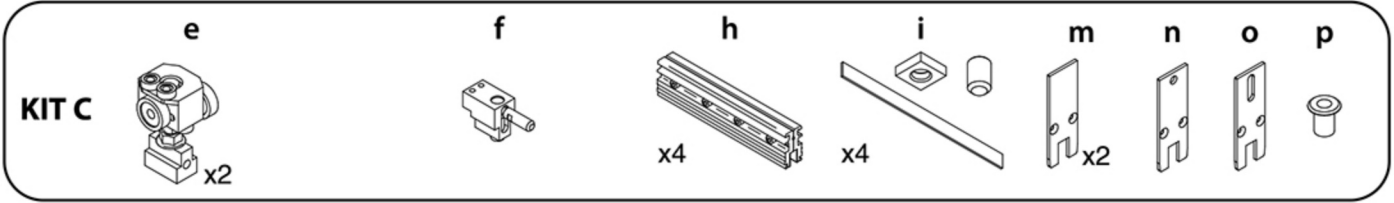
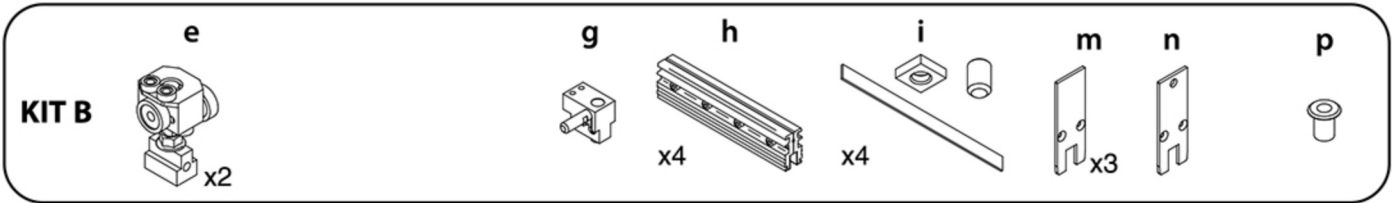
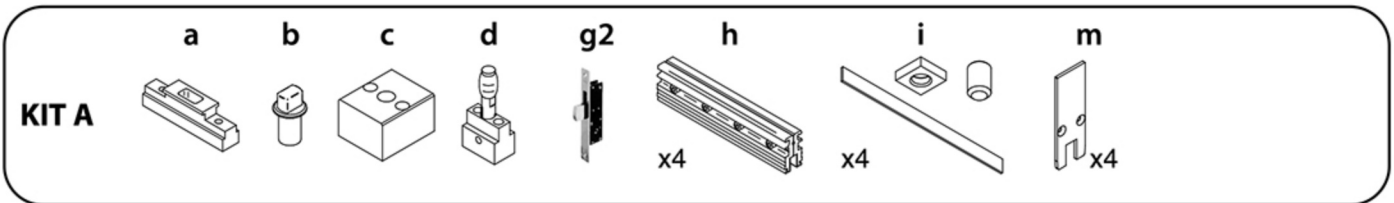

PROFILES



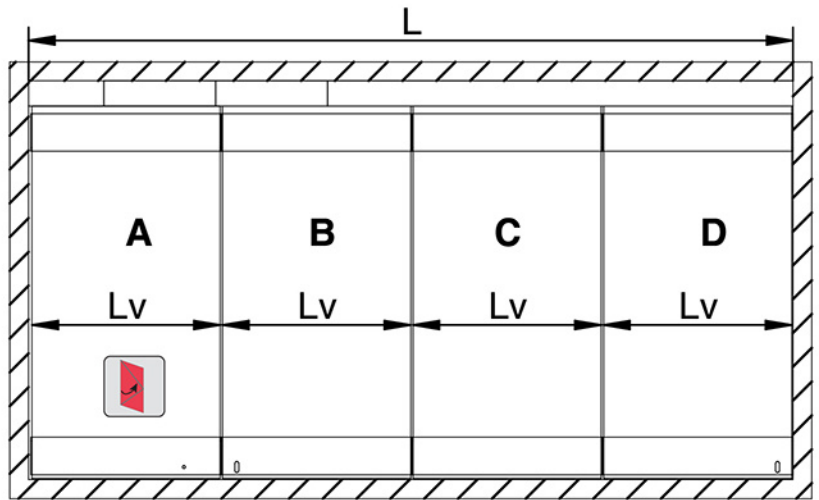
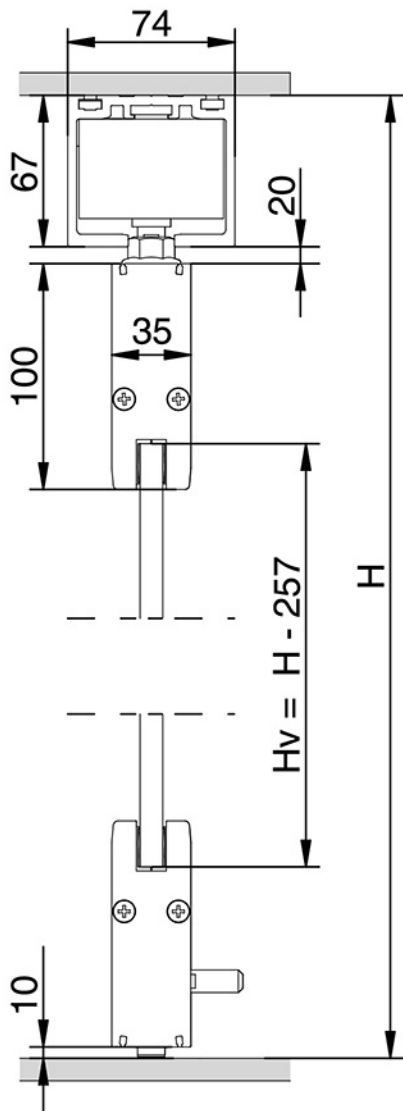

$$H_v = H - 257$$

$$L_v = \frac{L - 6}{N} - 6$$

N = number of panels

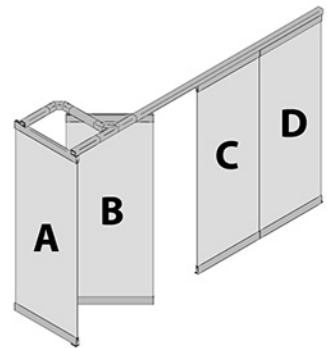

PROFILES

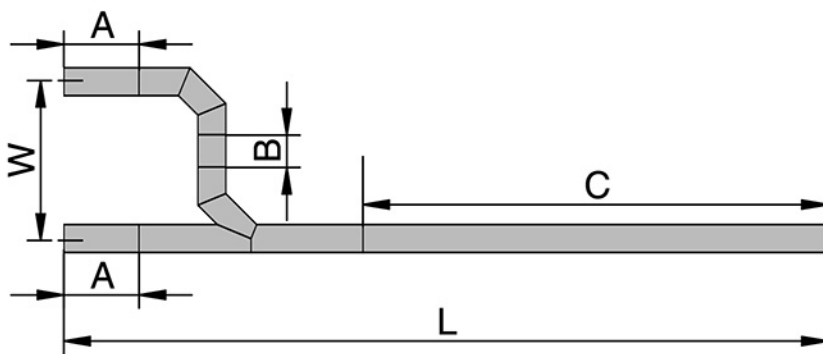

$$A = N \times 70$$

$$W = L_v - 140$$

$$B = W - 417$$

$$C = L - A - 594$$

Machining clamps profile



LP=LV

Panels B - D

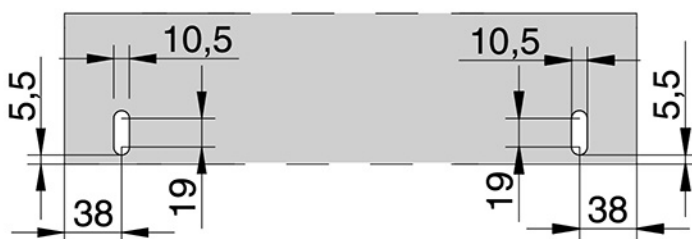

Panel A

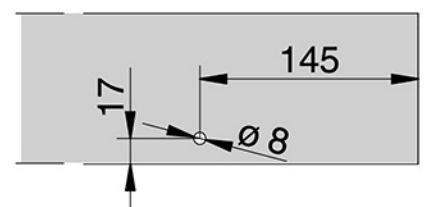

1a Profile assembly

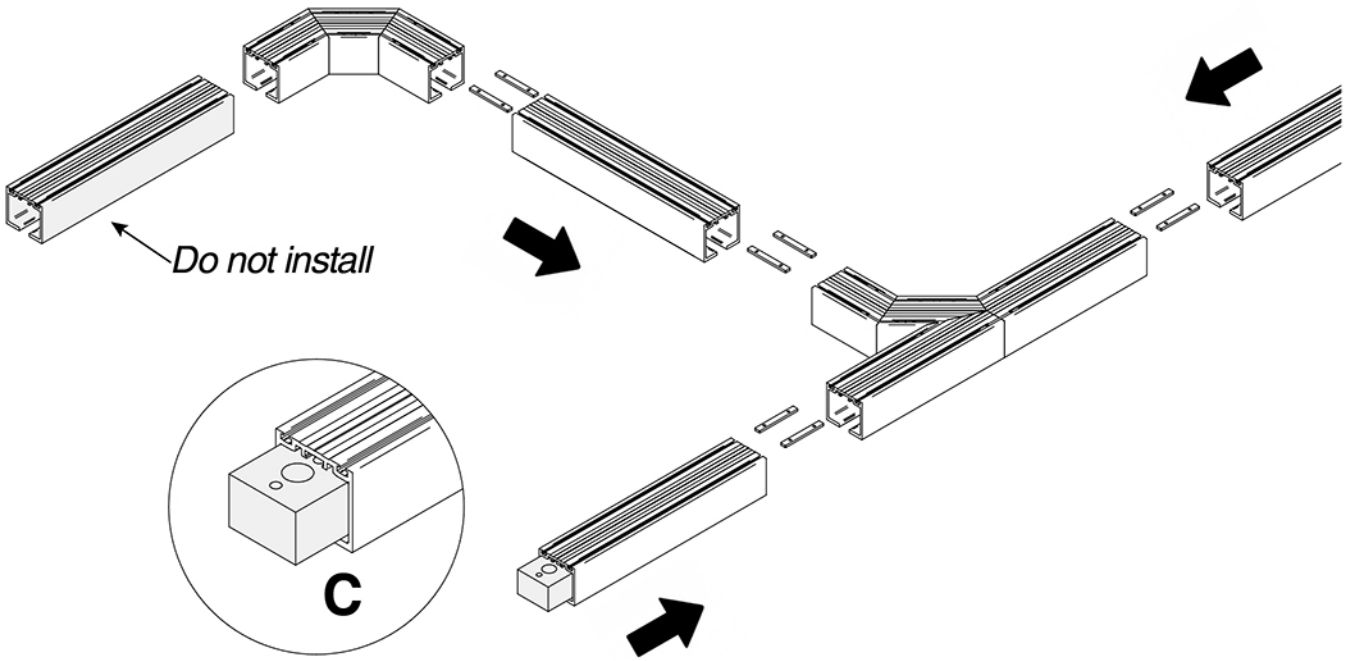

1b Profile fix

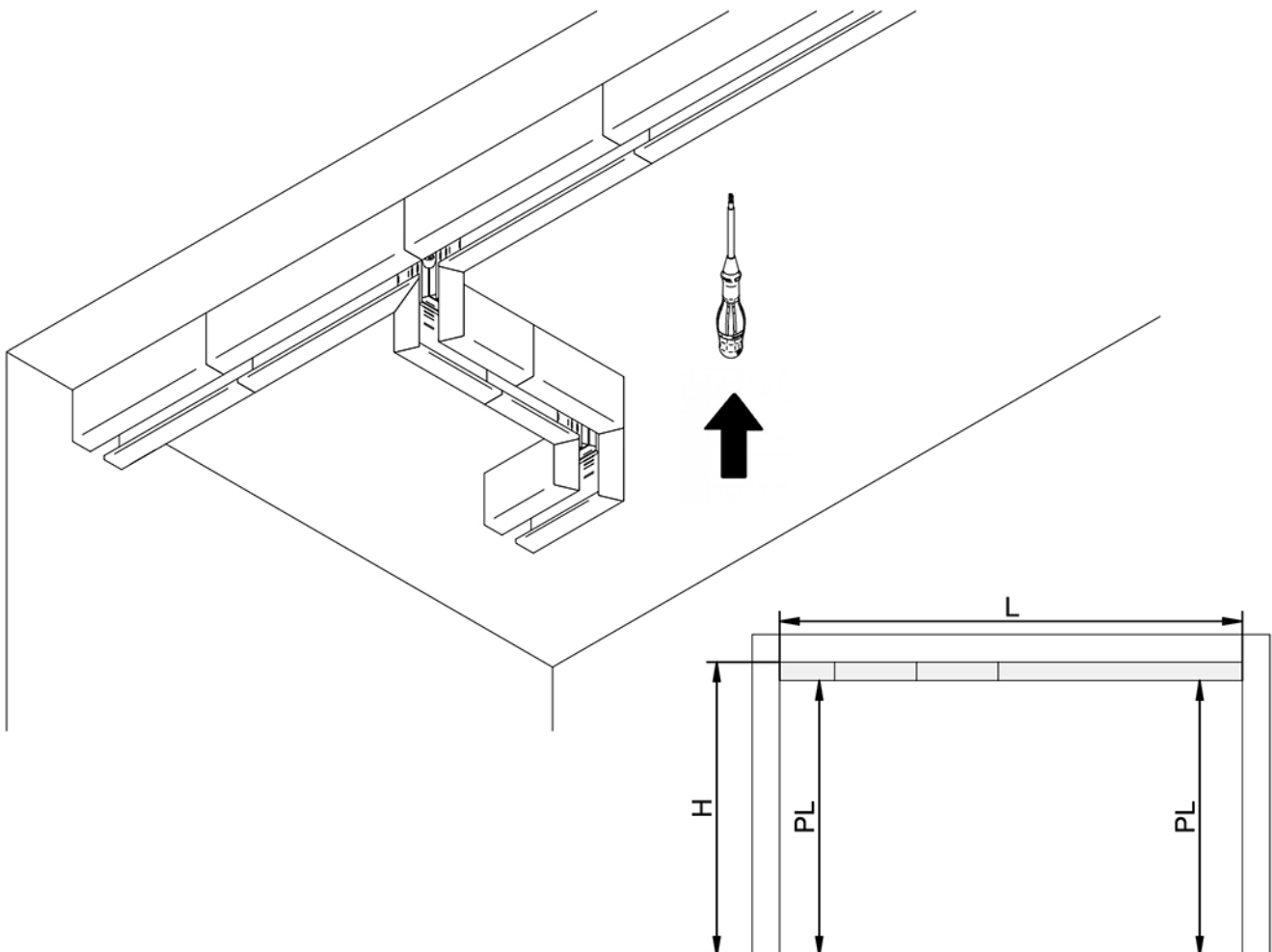

2 Assembly clamps profile

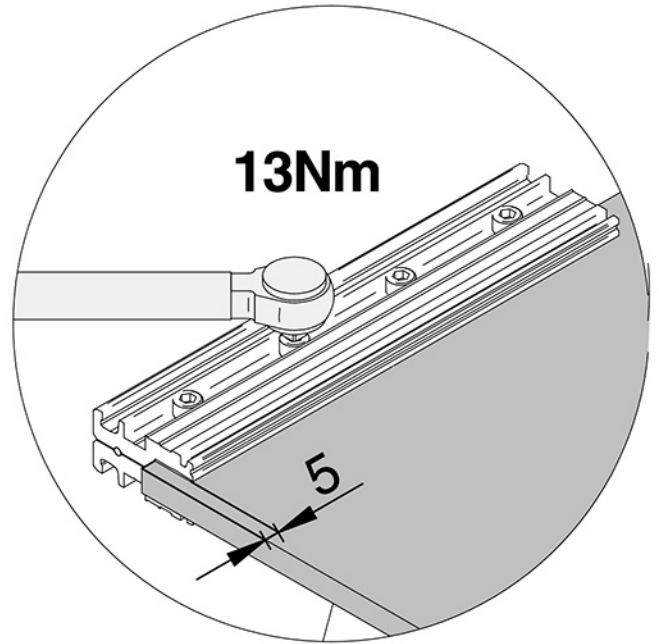
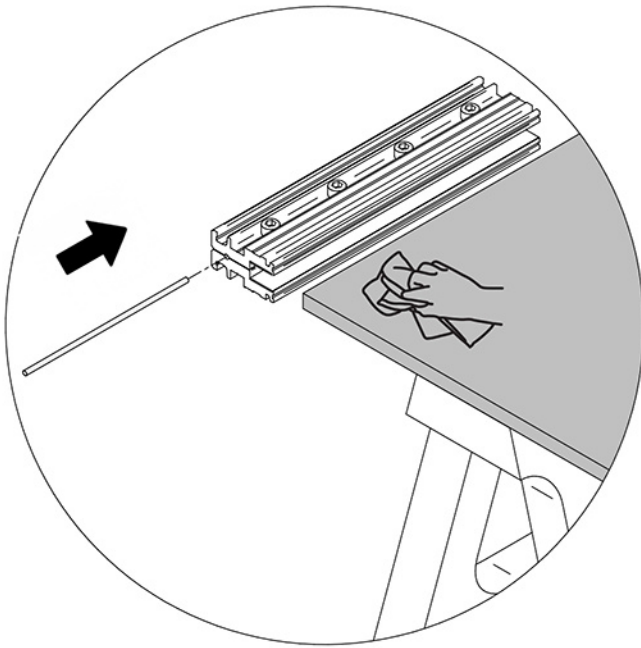

Insert the spacer in the clamp

Place and screw the clamp on the clean panel



Ø 3	10 mm
Ø 3,5	10,76 mm
Ø 4	12 mm
Ø 4,5	12,76 mm

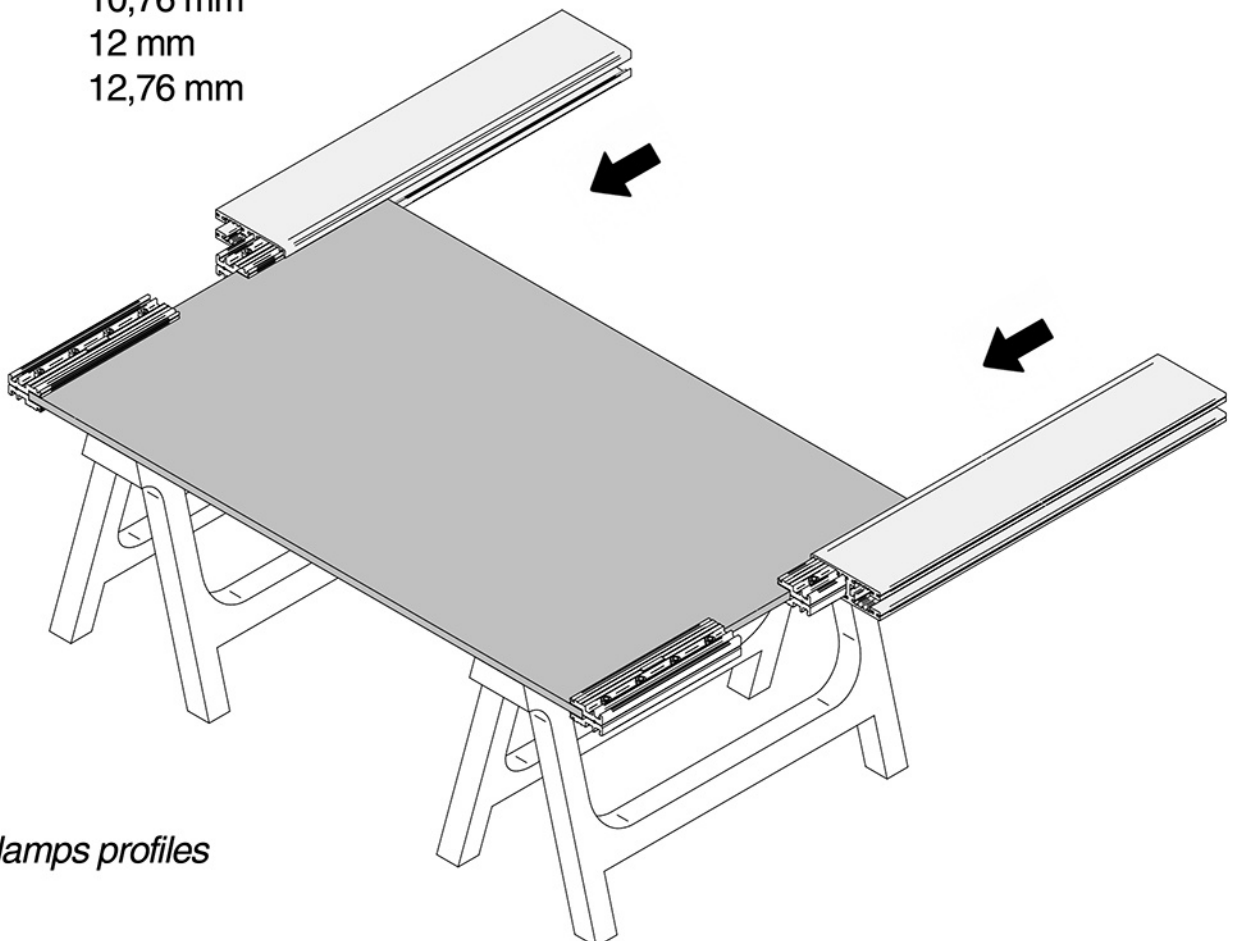

Insert clamps profiles

3 Tightening clamp profile

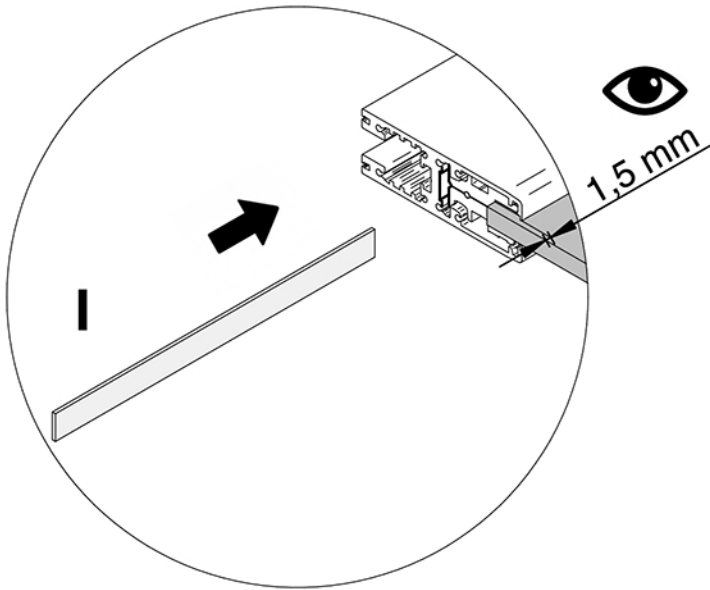

Insert the platelet in the clamp profile

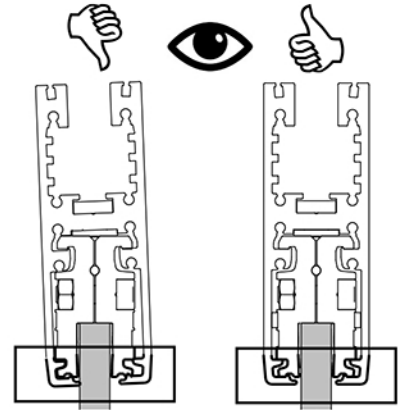

Verify the right position of the clamp

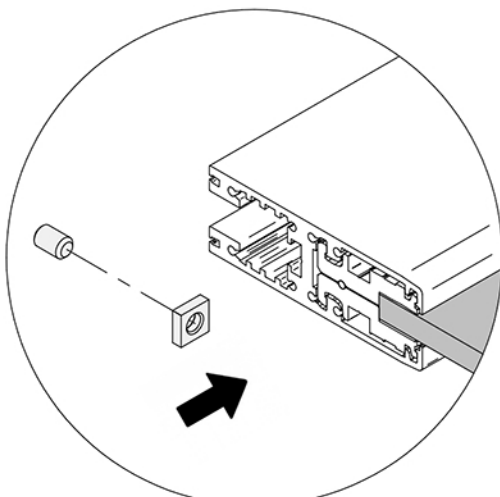
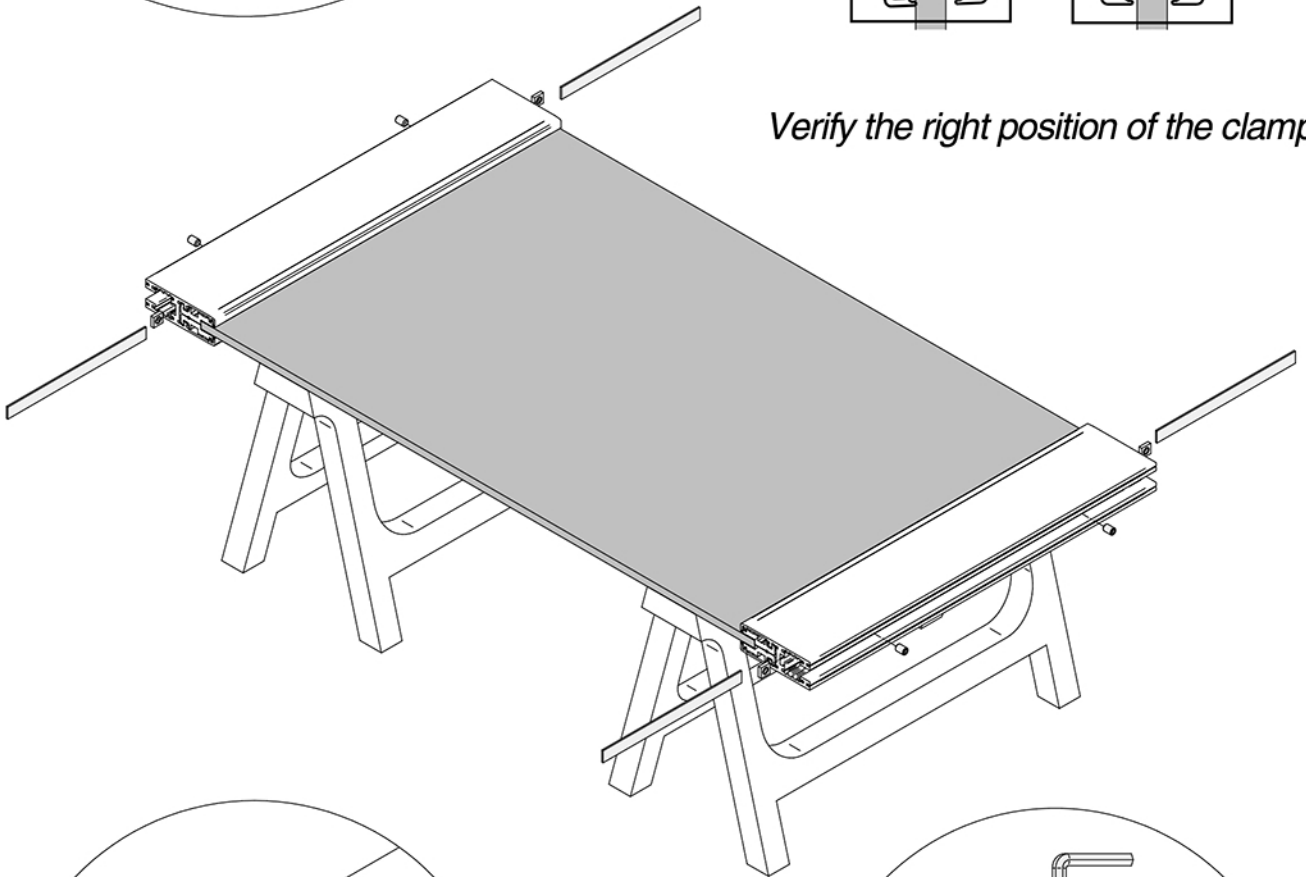

Screw

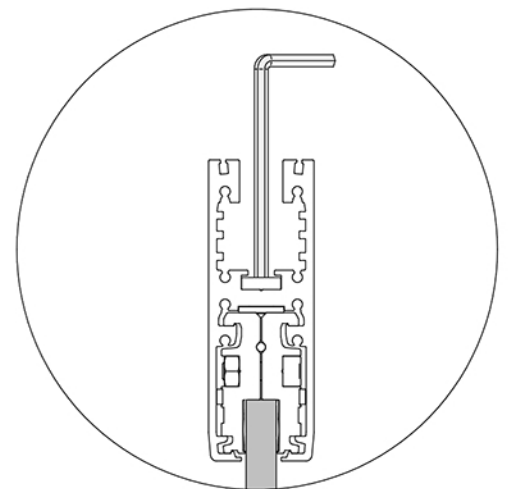

4 Assembly panel "D"

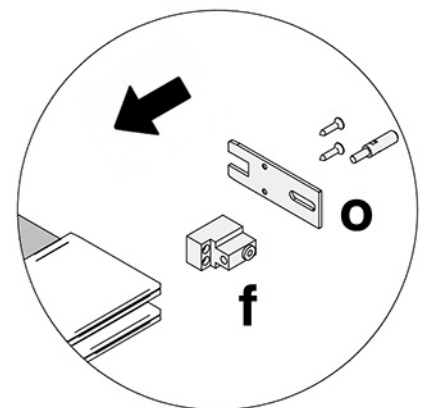
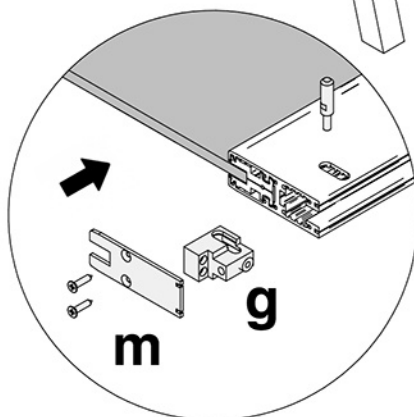
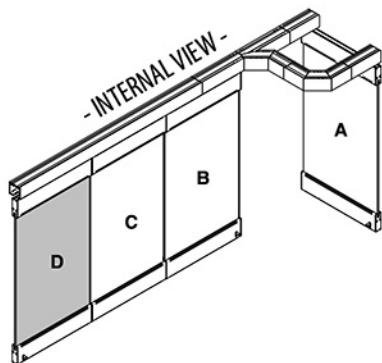
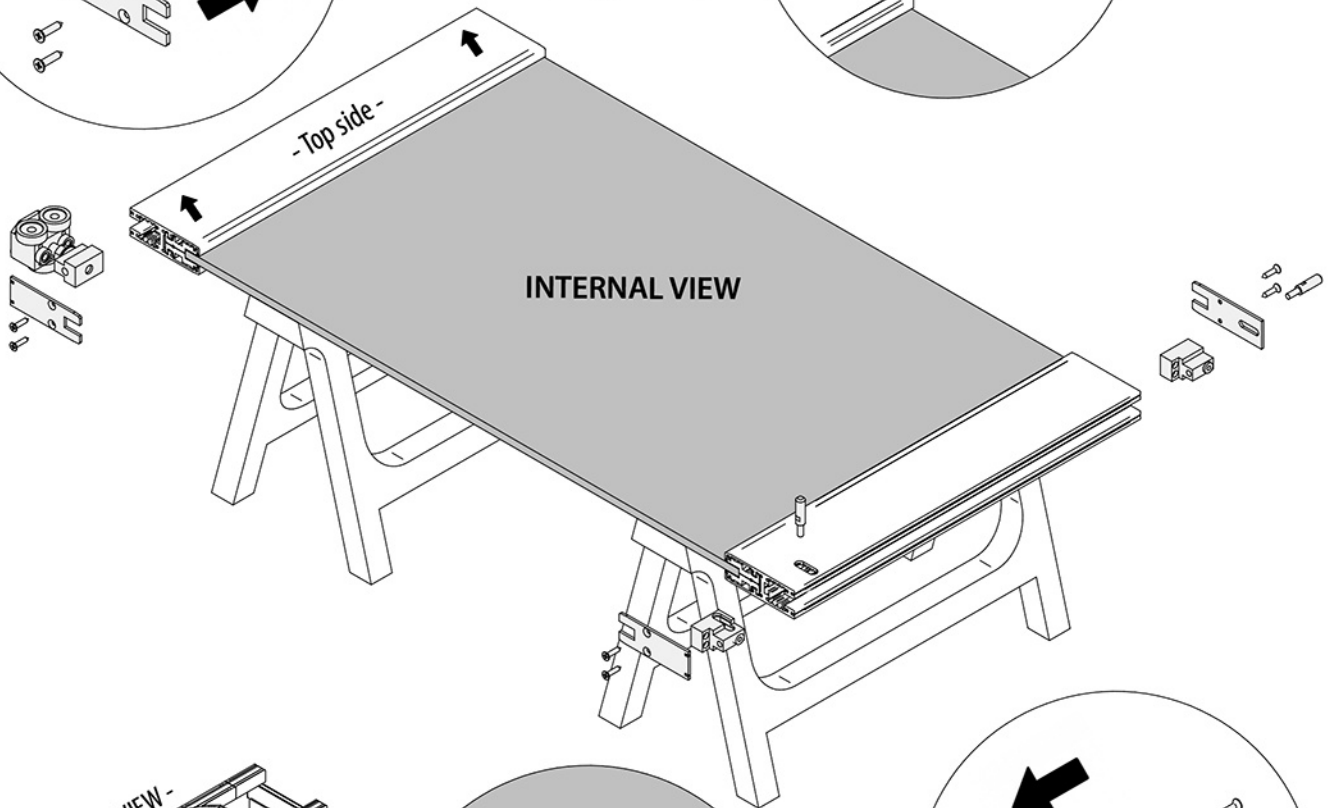
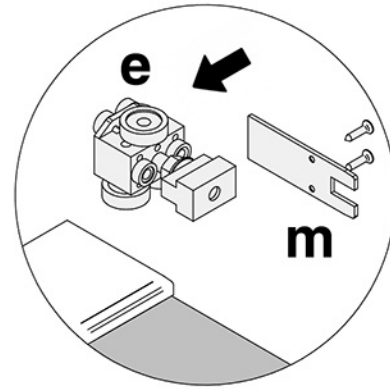
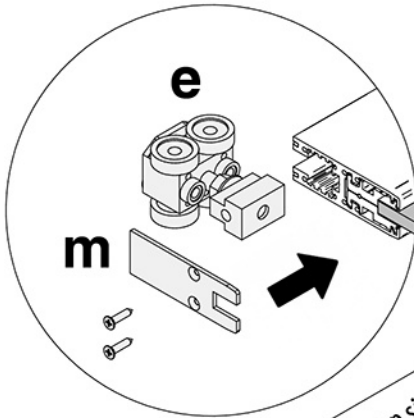
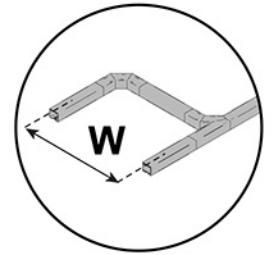
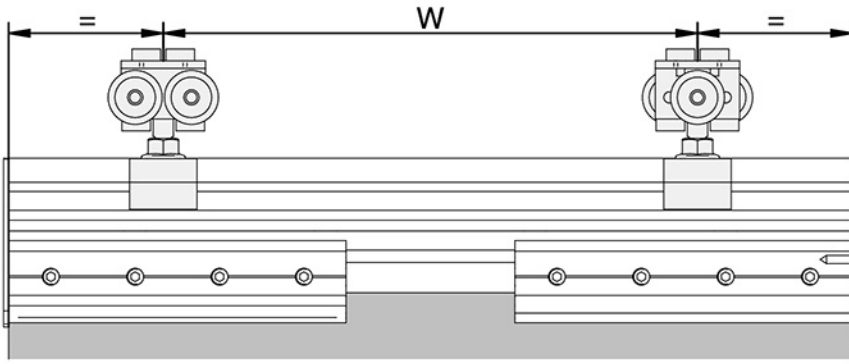

5 Assembly panel "C"

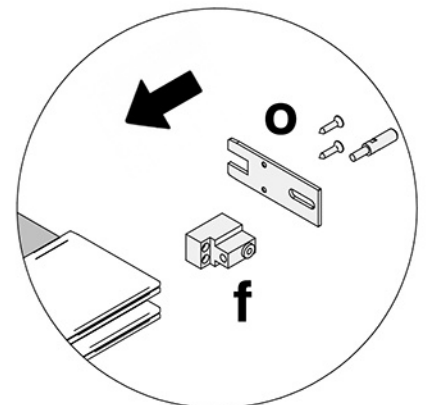
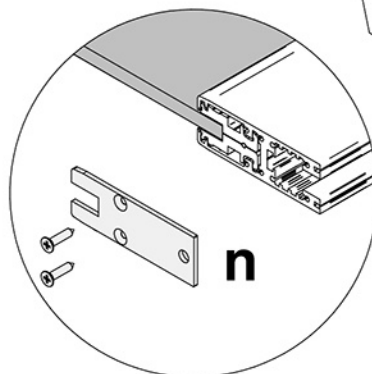
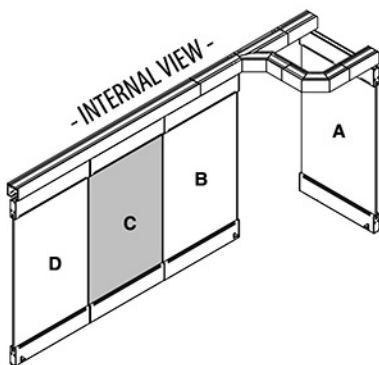
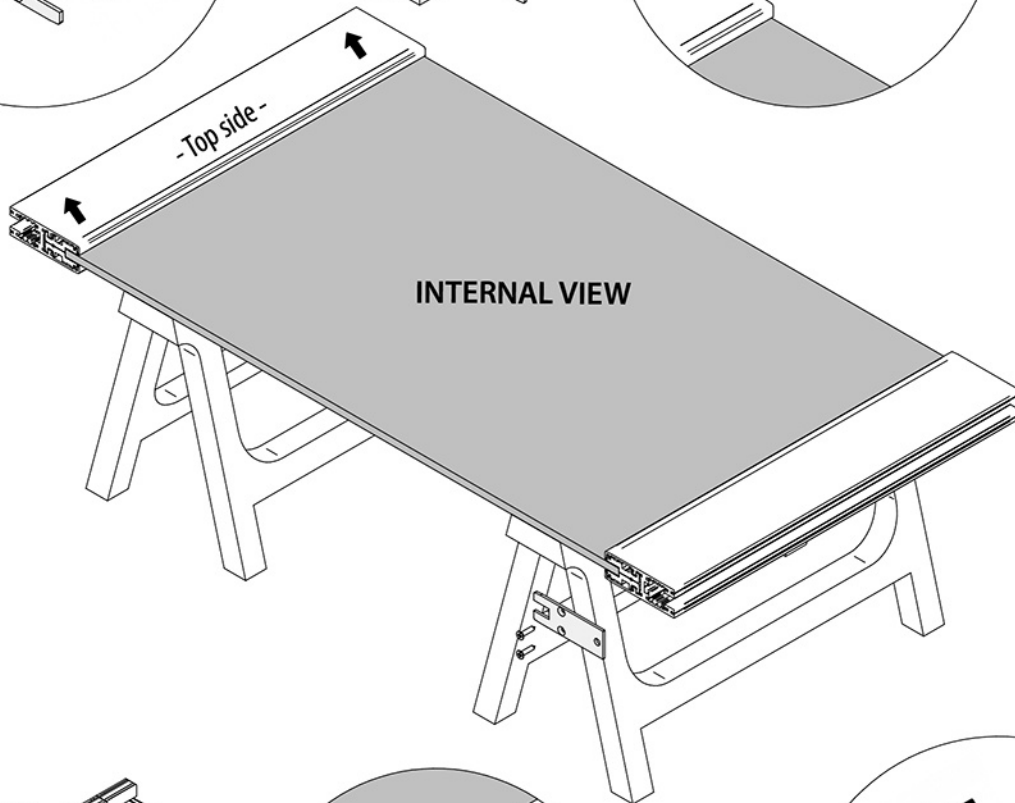
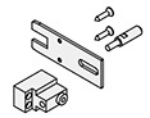
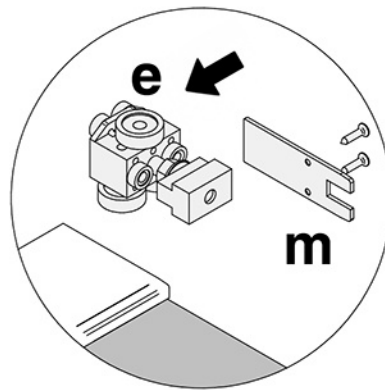
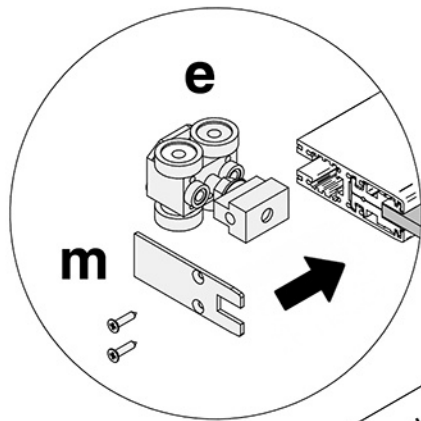
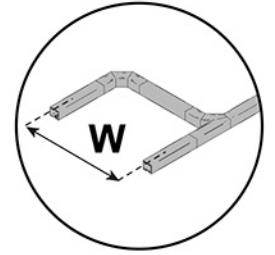
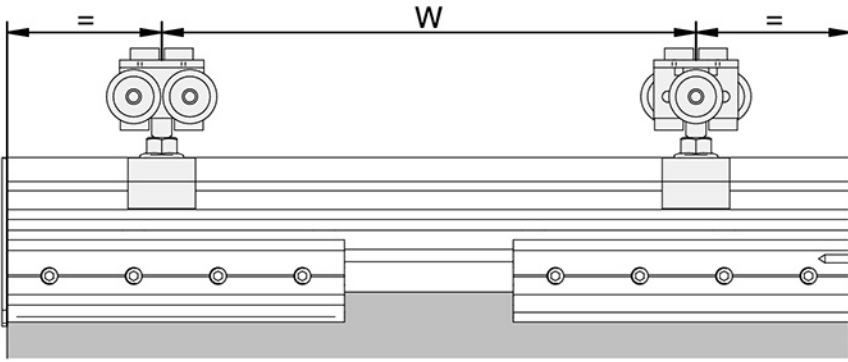

6 Assembly panel "B"

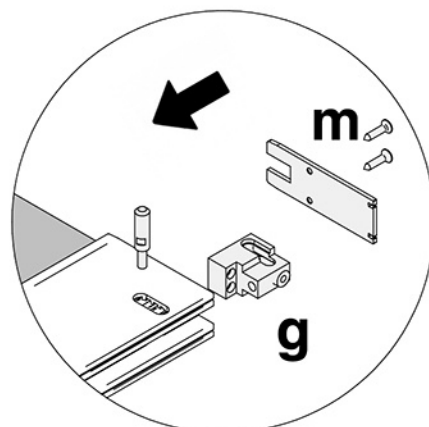
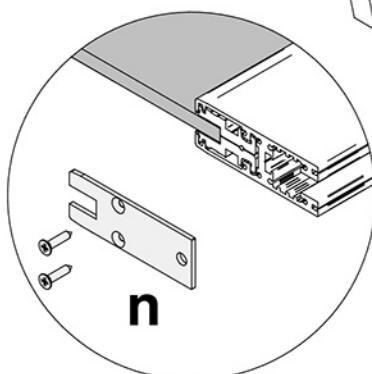
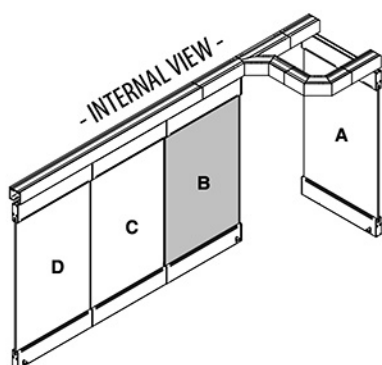
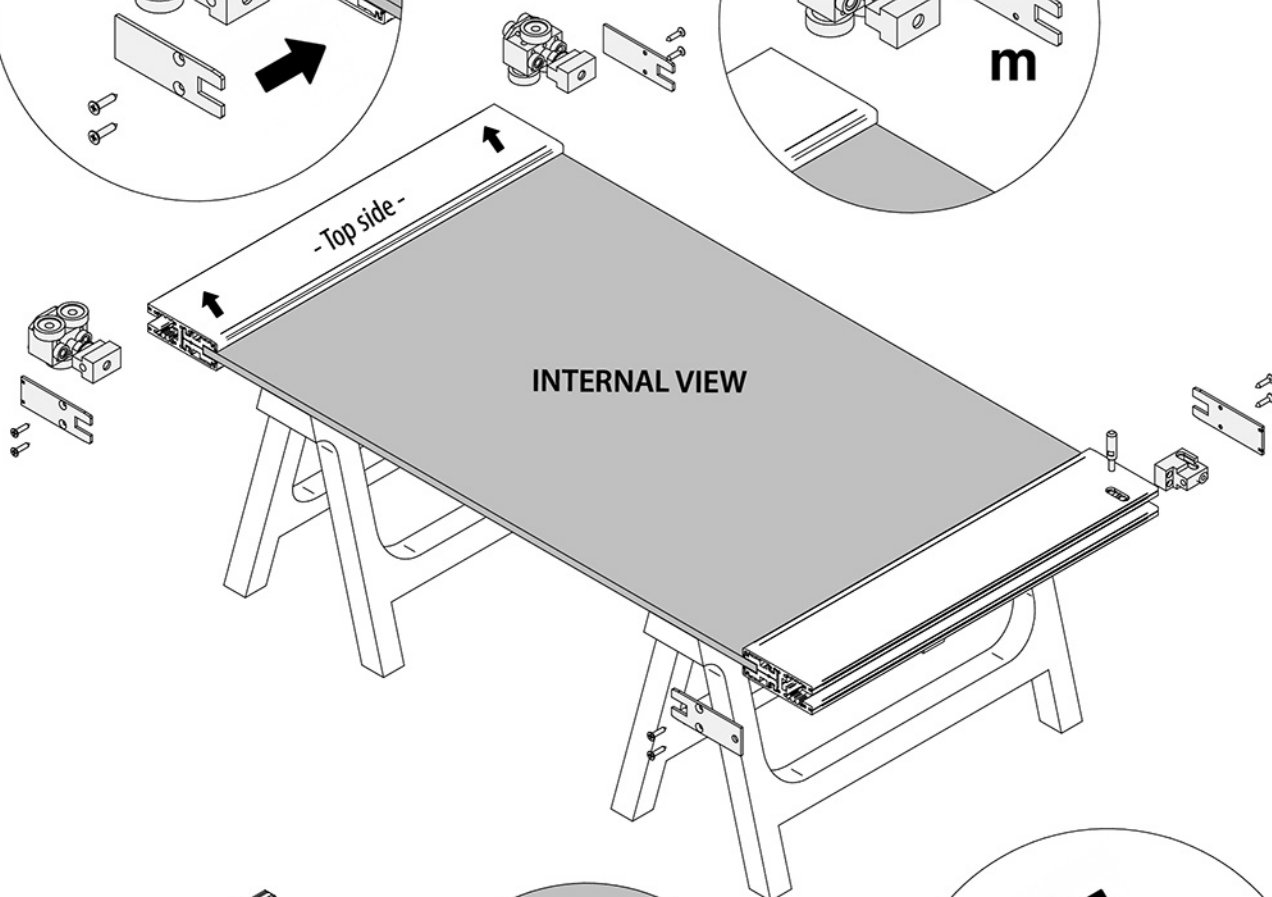
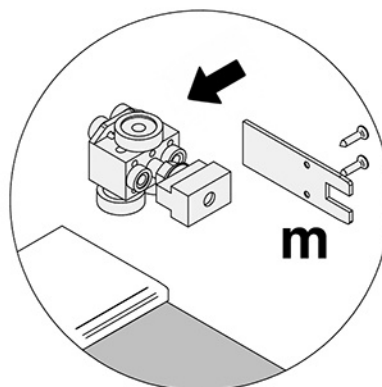
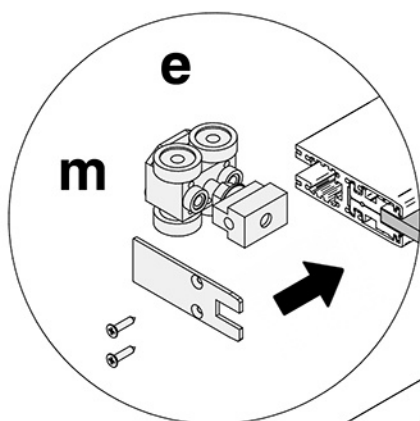
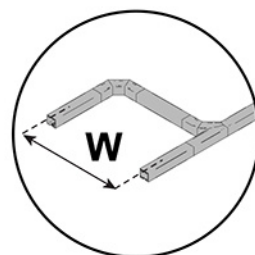
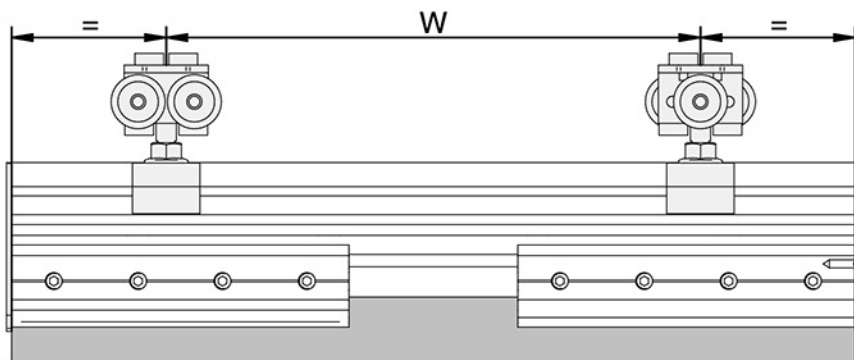

7 Assembly panel "A"

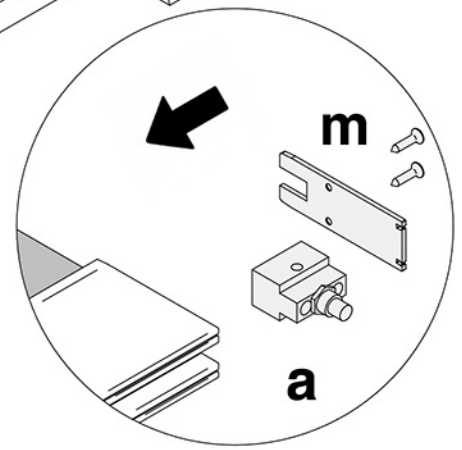
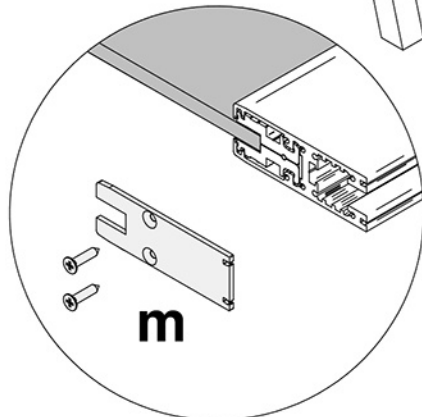
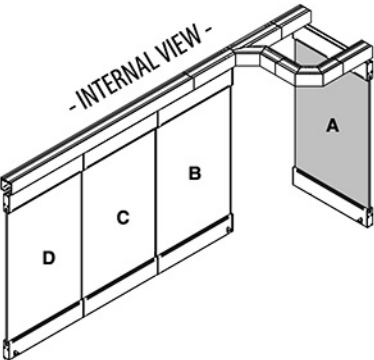
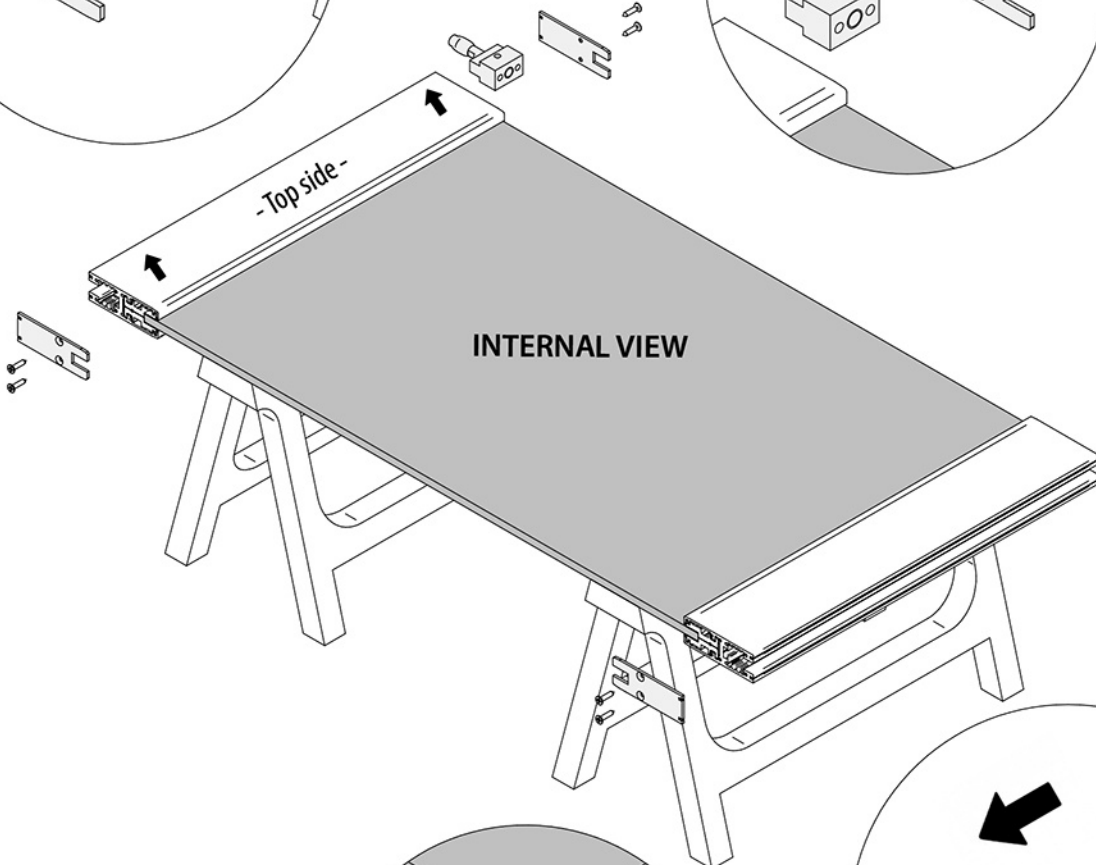
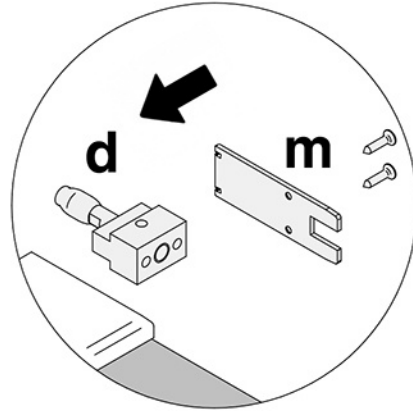
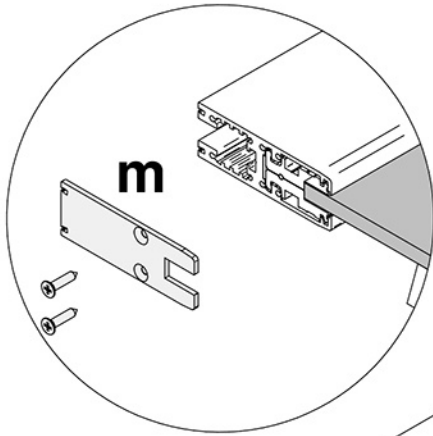
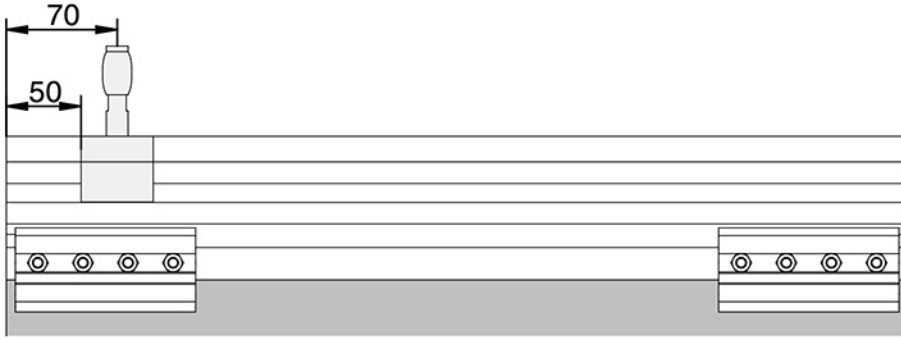

12 Adjust and screw the trolley

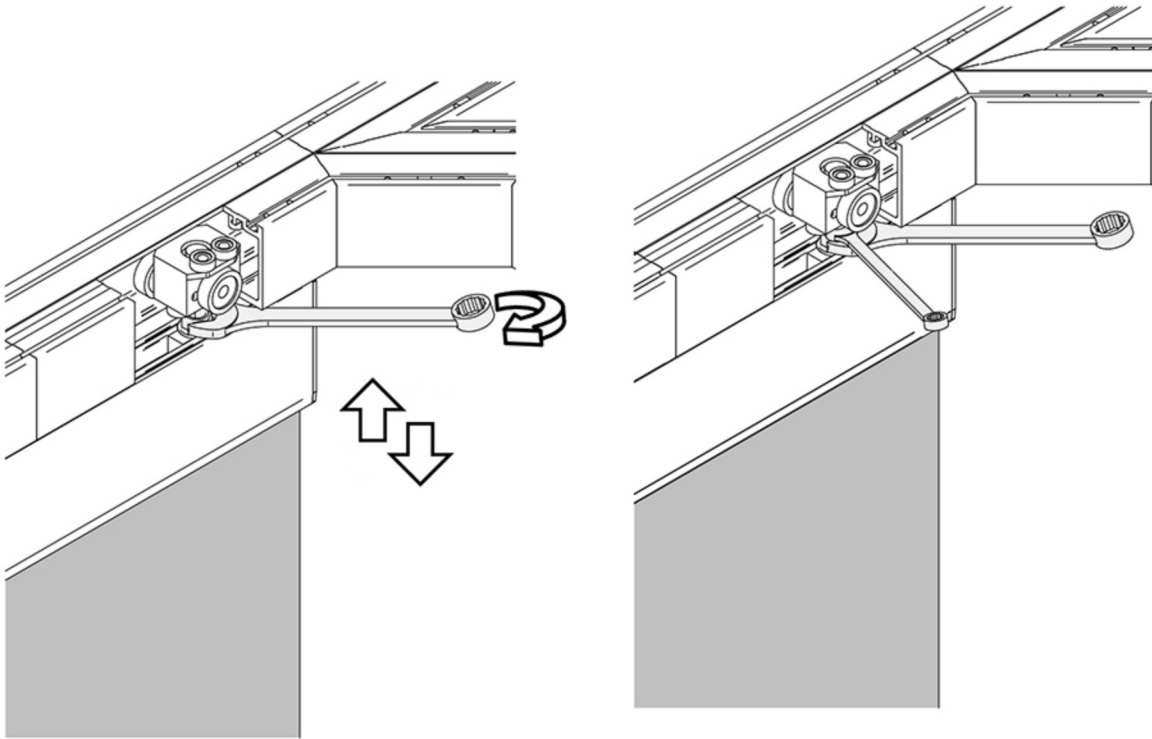

13 Assembly brushes and seals

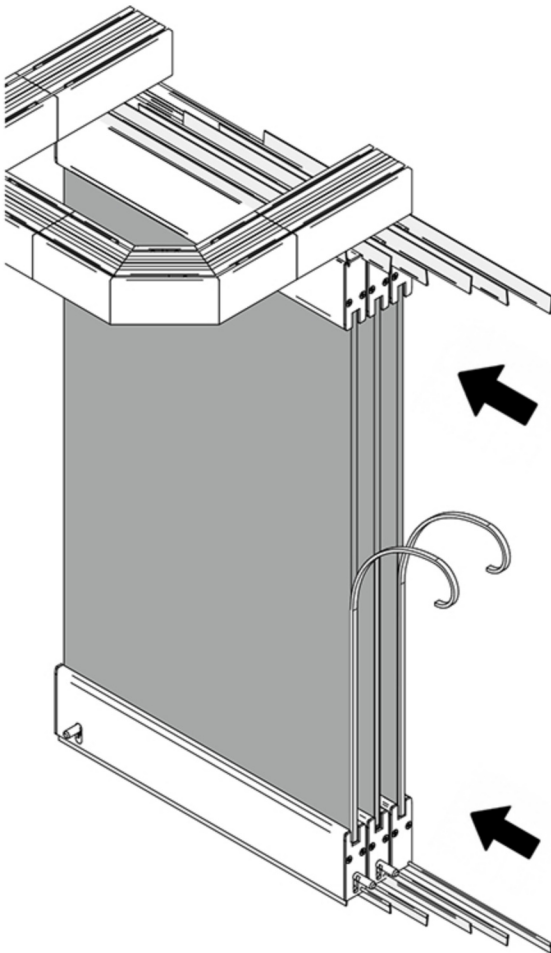

20 mm

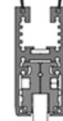

10 mm



Clean with our glass cleaner Hendrika
779118010000



Do not install on cold glass

8 Panels mounting

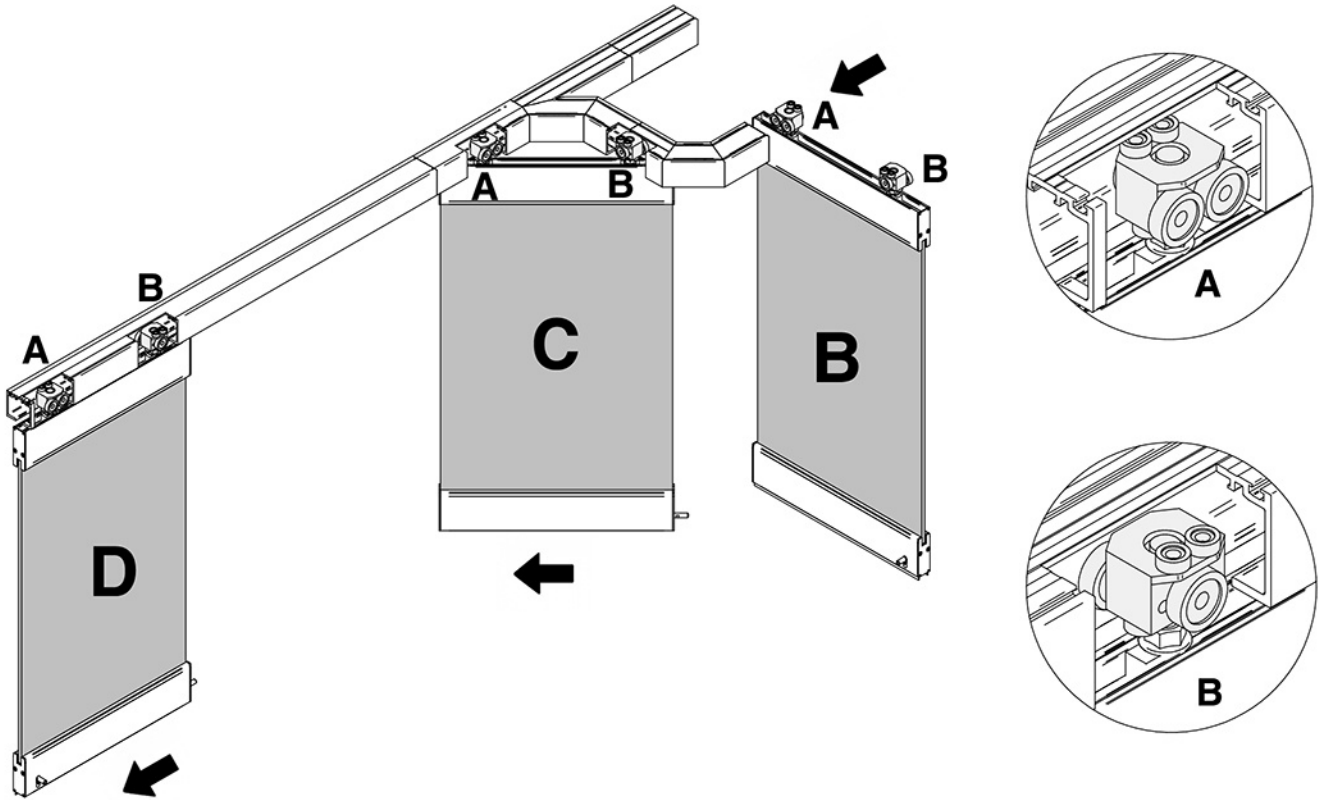

9 Section profile fix

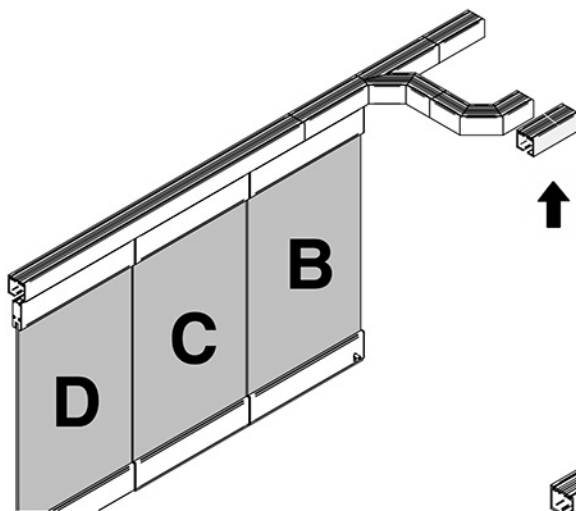

10 Fix the switch component

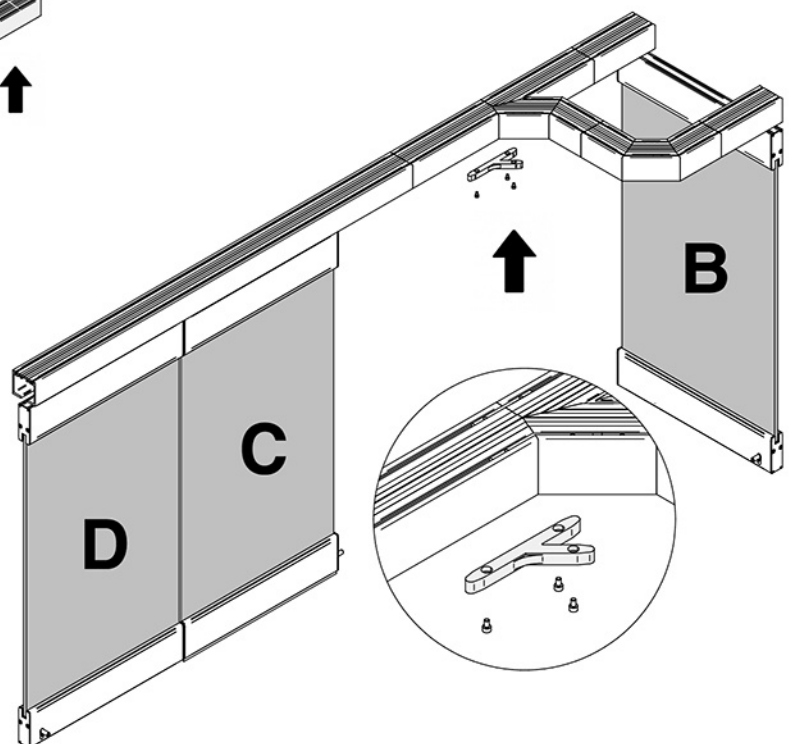

14 Assembly floor bush

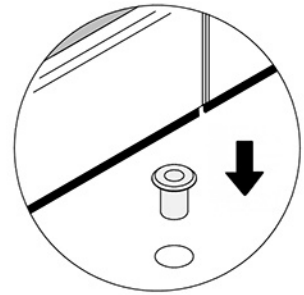
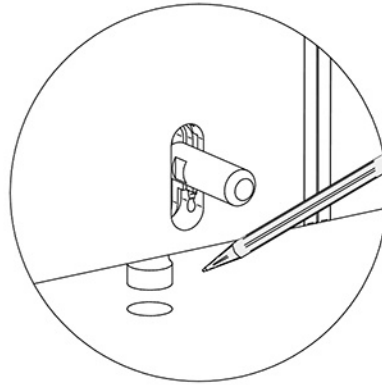
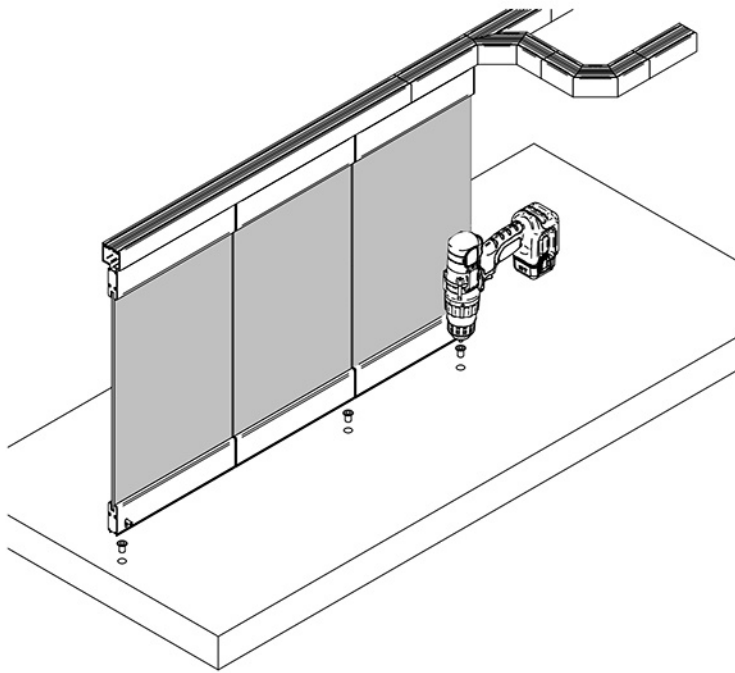

15 Panels mounting "A"

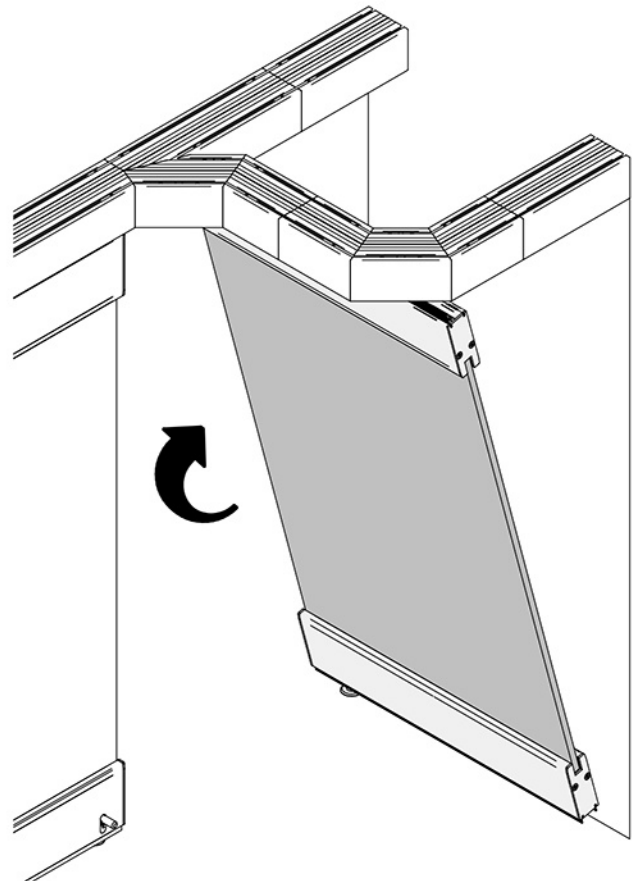
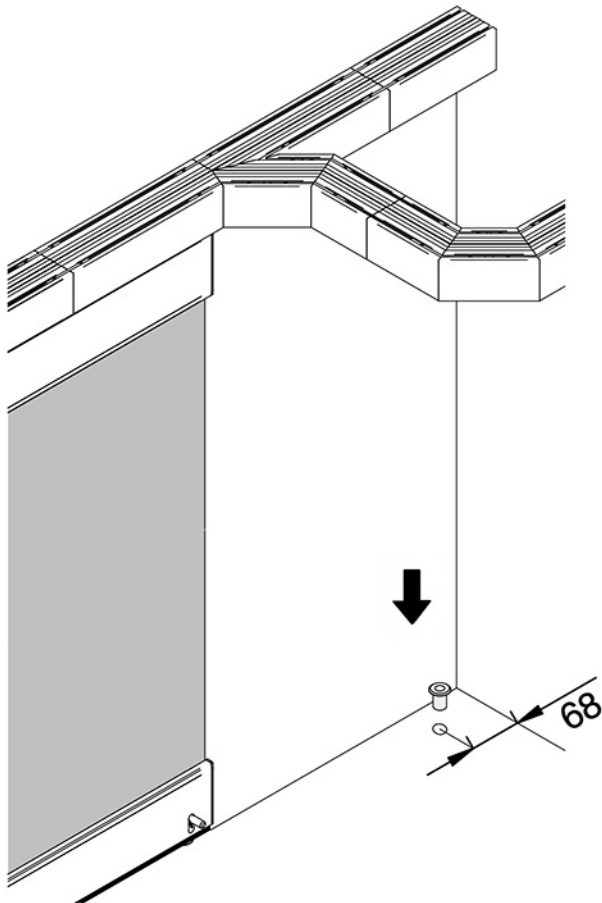

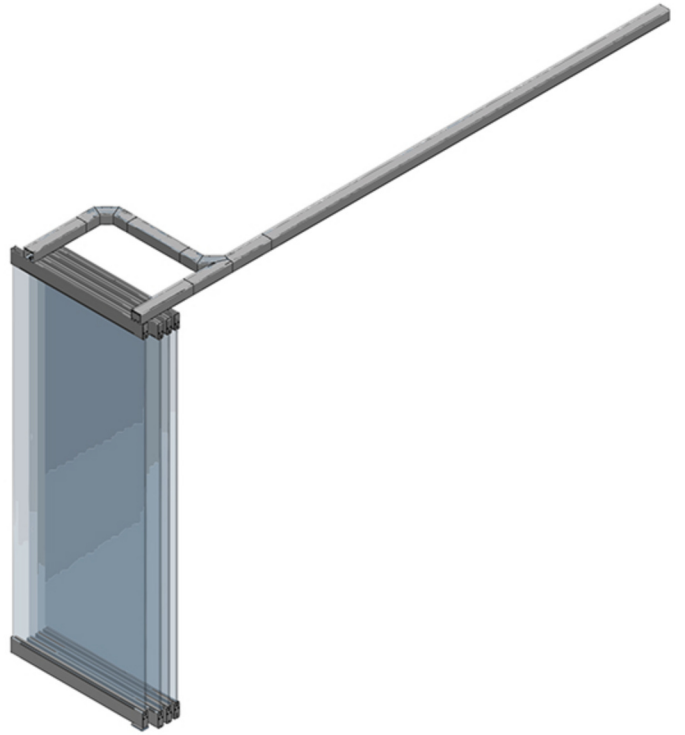
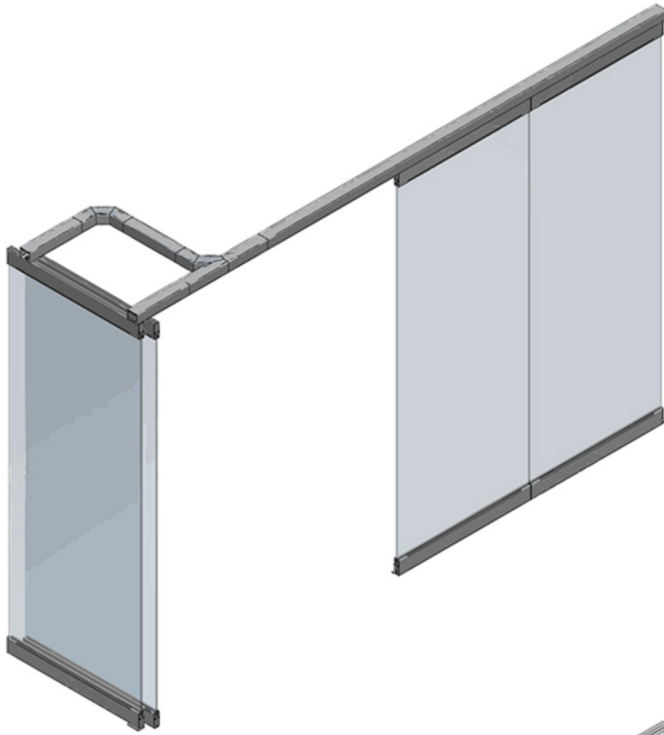
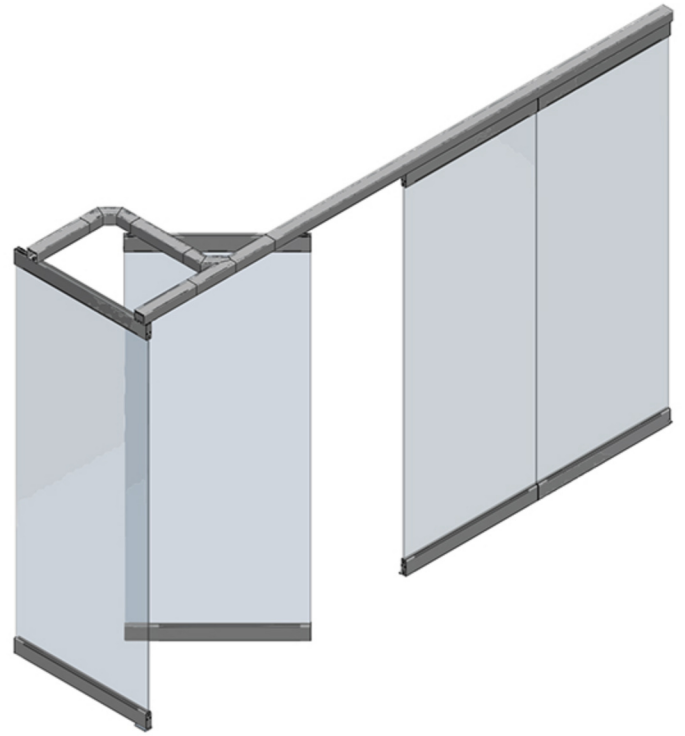
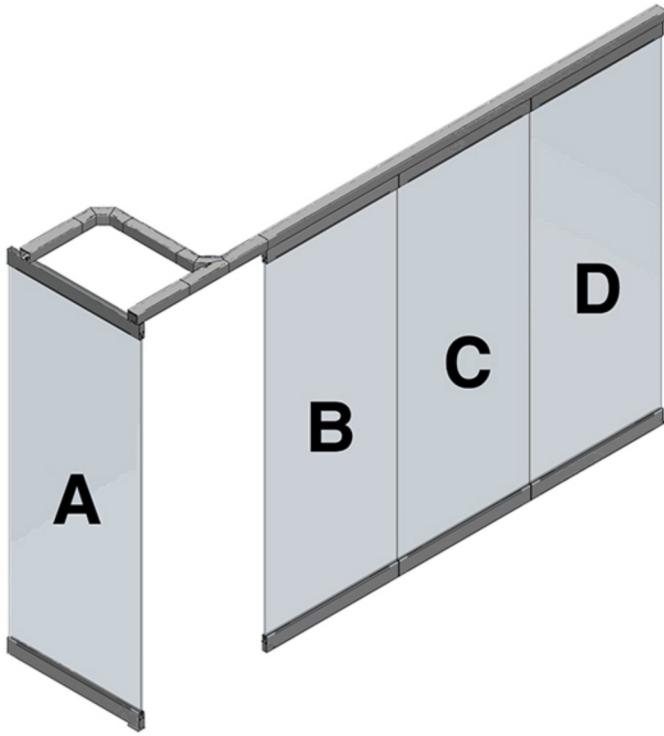

"A" + "B" + "D" + ∞ "C"

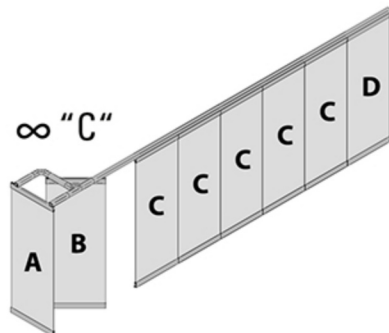

G-FITTINGS GmbH

Marie-Curie-Straße 16-18
46446 Emmerich am Rhein

T +49 (0)2822 962 0

E sales@g-fittings.com