

Technische Daten:
Eckbeschlag hydraulisch - Levi

Datasheet:
Hydraulic Patch Fitting - Levi

Art. 77450106000-12
Art. 77450106000-26

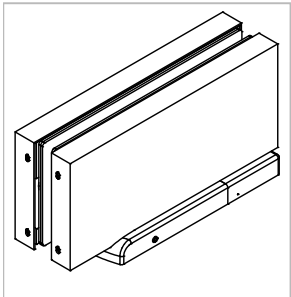

Ausführung:
Options:

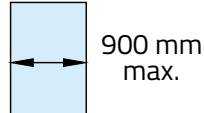
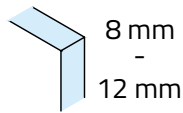

Material: Aluminium
Material: Aluminium

Gewicht: / Weight: 2,45 kg

Oberflächen: Edelstahl-Design
Finish: Stainless steel design

Anthrazit-Design
Antracite design

Im Lieferumfang enthalten:

Scope of supply:

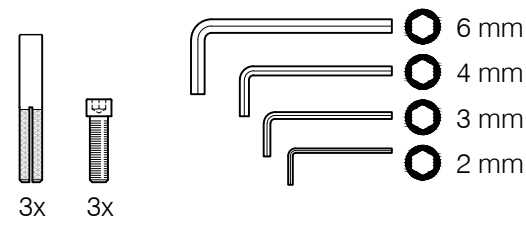

Montagewerkzeug und Material:

Mounting tools and supply:

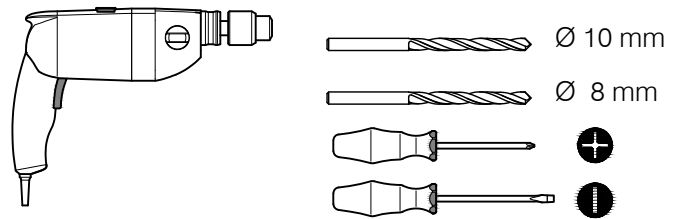

Abmaße:
Dimensions:

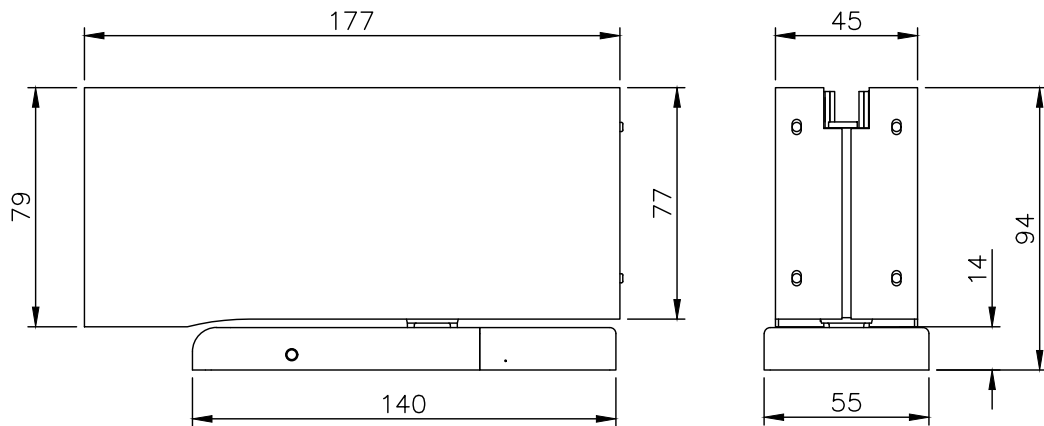

Glasausschnitt:
Glass cut out:

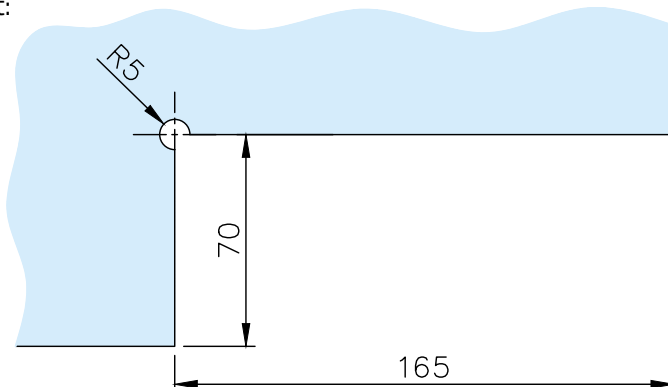

G-FITTINGS GmbH

Marie-Curie-Straße 16-18
46446 Emmerich am Rhein
T +49 (0)2822 962 0
E sales@g-fittings.com

Abmaße verschiedener Montage-Möglichkeiten:
 Dimensions of various mounting options:

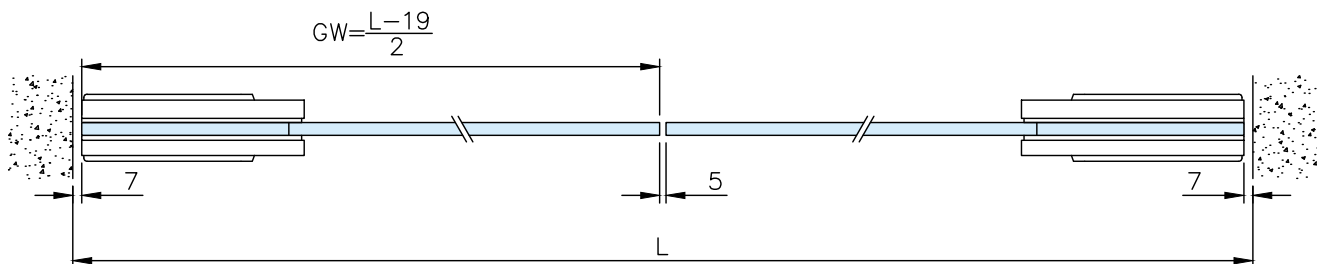
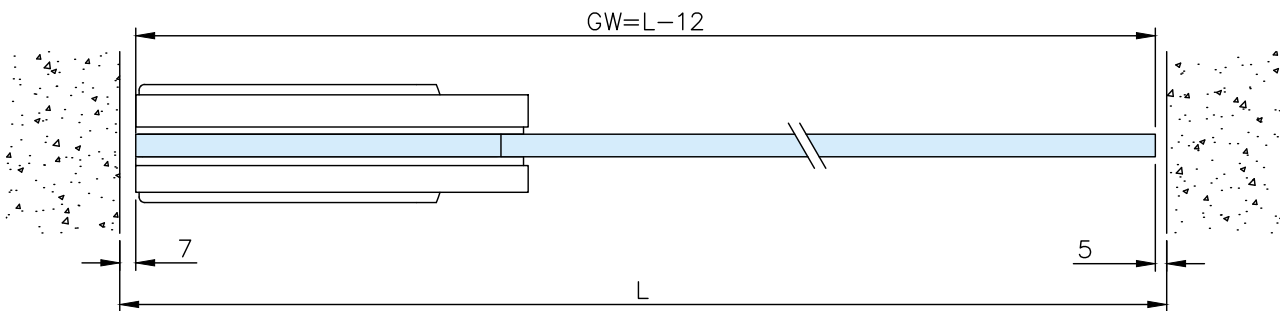
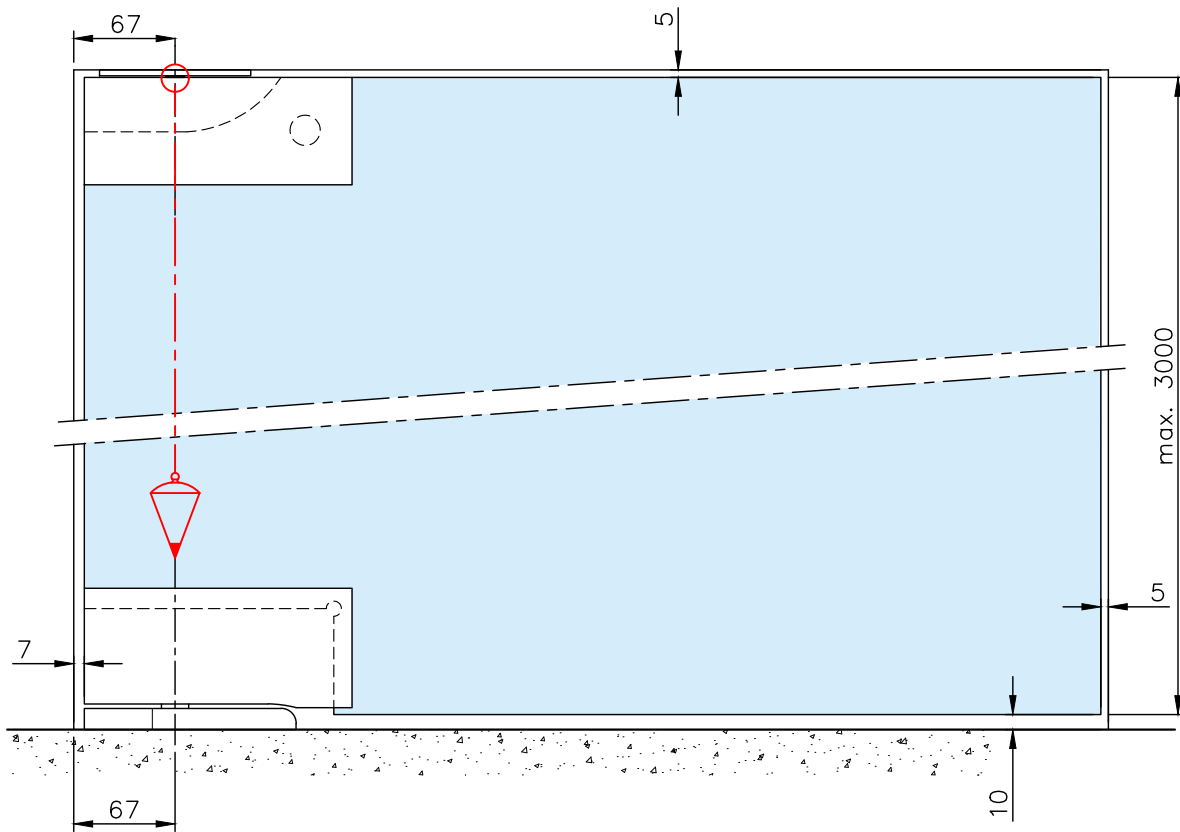

1. Montage der Basis:
1. Mounting the base:

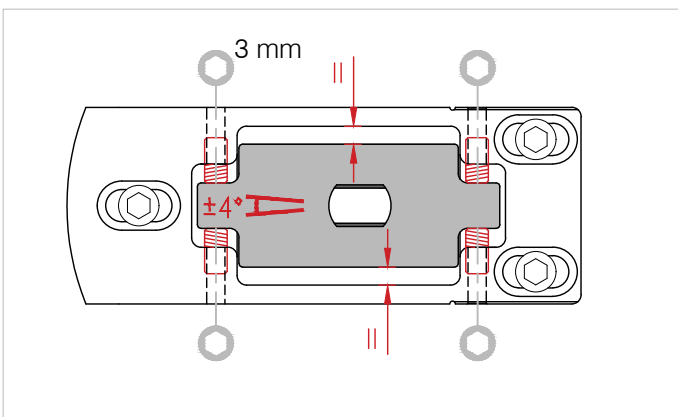
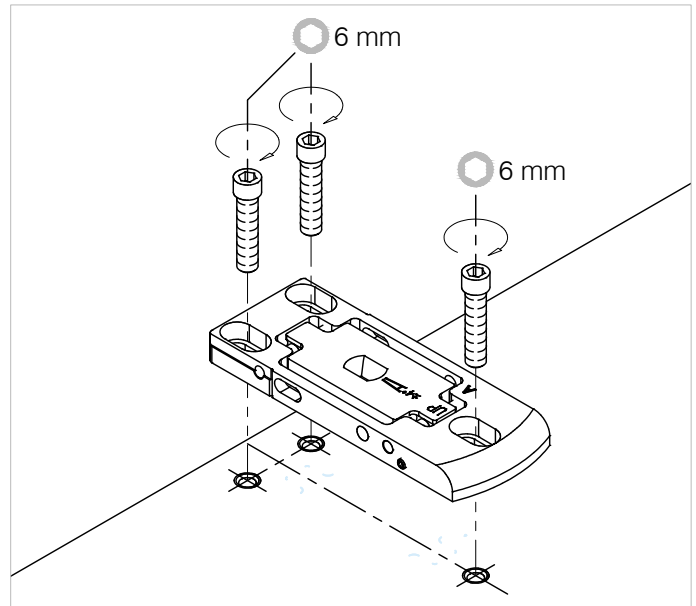
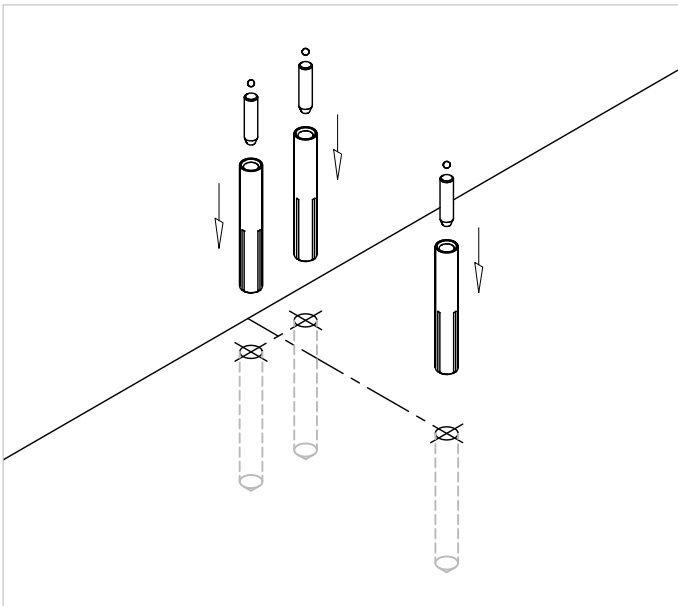
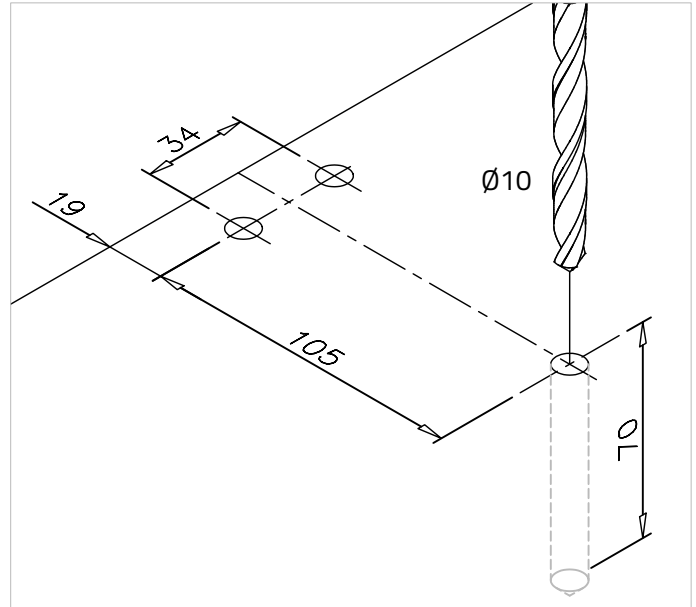
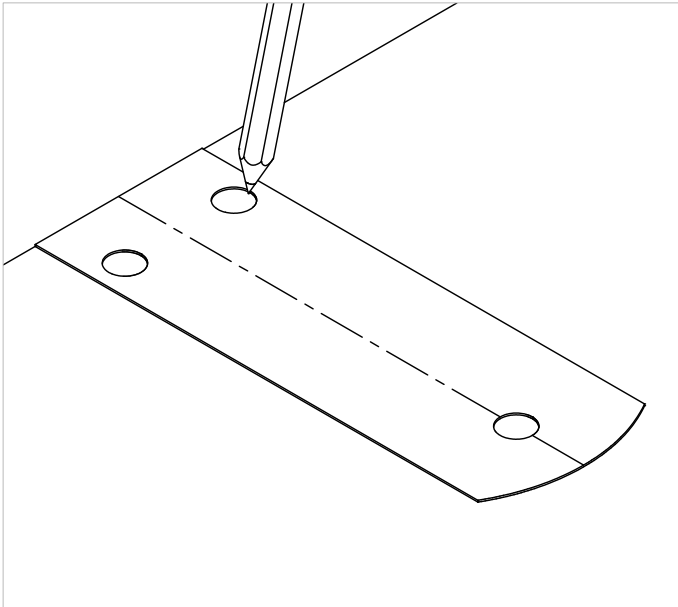

! Die Einstellplatte sollte symmetrisch in der Basis liegen. Falls nicht, dann stellen Sie diese mit Hilfe der Gewindestifte ein.
The adjustment socket should be symmetrical in the base. If not, then adjust it mithilfe from the set screws.

2. Patchfitting an das Glas anbringen:
2. Patch fitting to the glass

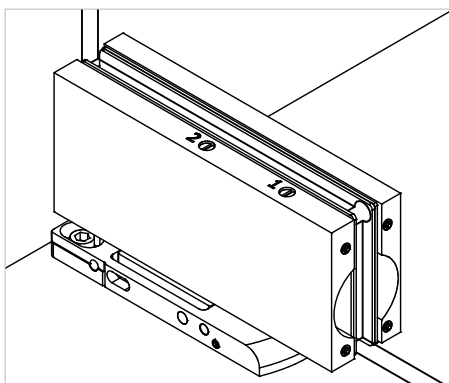
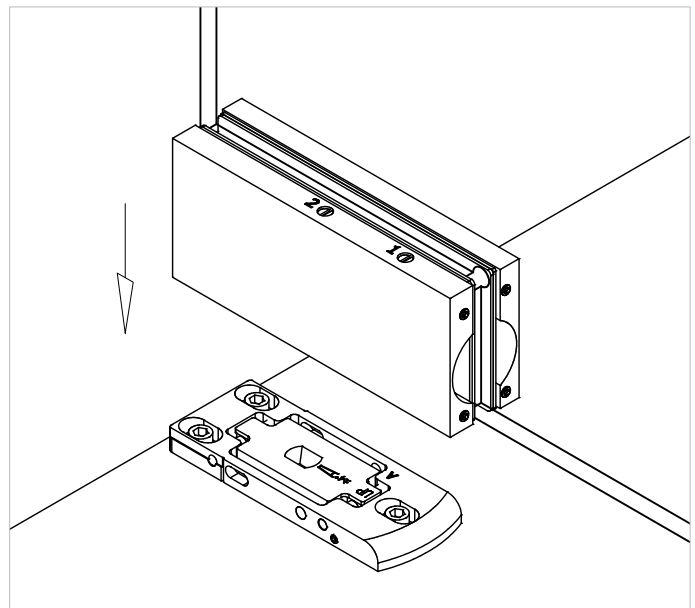
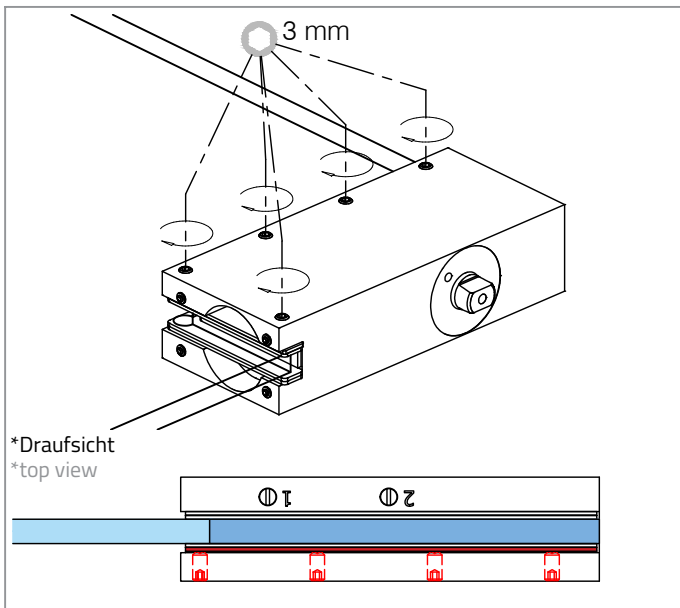
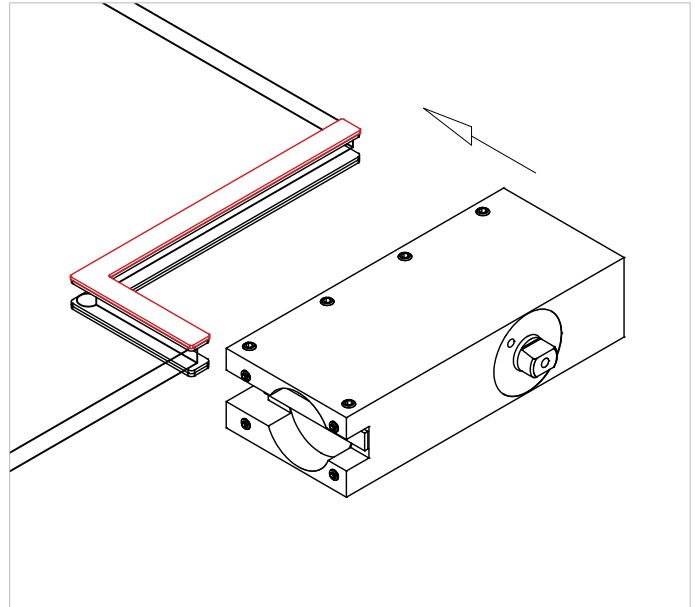
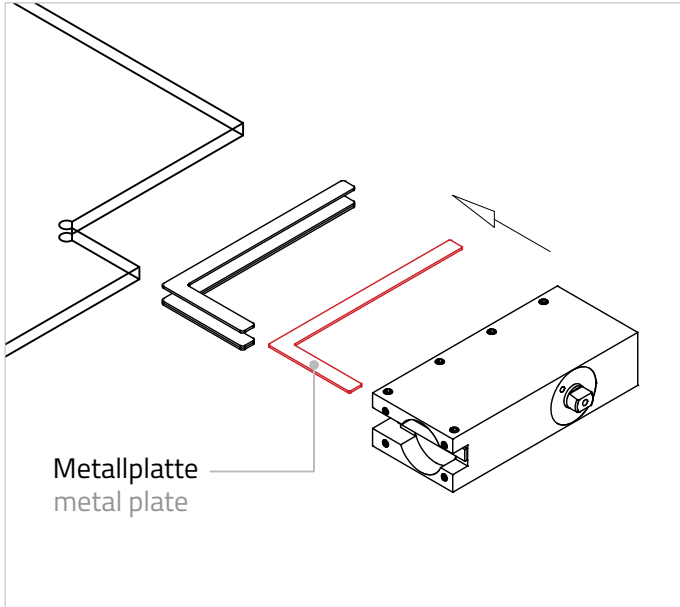

Glasstärke: Glass thickness:	Anzahl der Gummis: Number of rubbers:
12 mm	2 Rubbers (1 mm)
10 mm	2 Rubbers (1,5 mm)
8 mm	4 Rubbers (1,5 mm)

Wichtig: Vor der Montage das Glas im Bereich der Klemmfläche reinigen.
Wir empfehlen G-Fittings Glasreiniger art. 91.1800.000.00

Important: Before mounting, clean the glass in the area of the clamp surface.
We recommend G-Fittings glass cleaner art. 91.1800.000.00

3. Einstellung der Vertikalenlage:
3. Adjustment of vertical position.

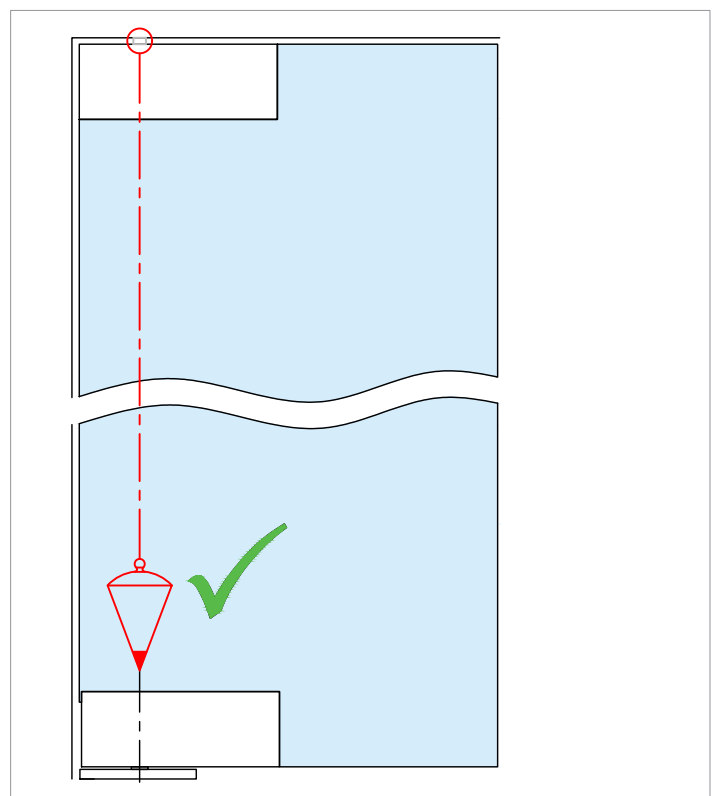
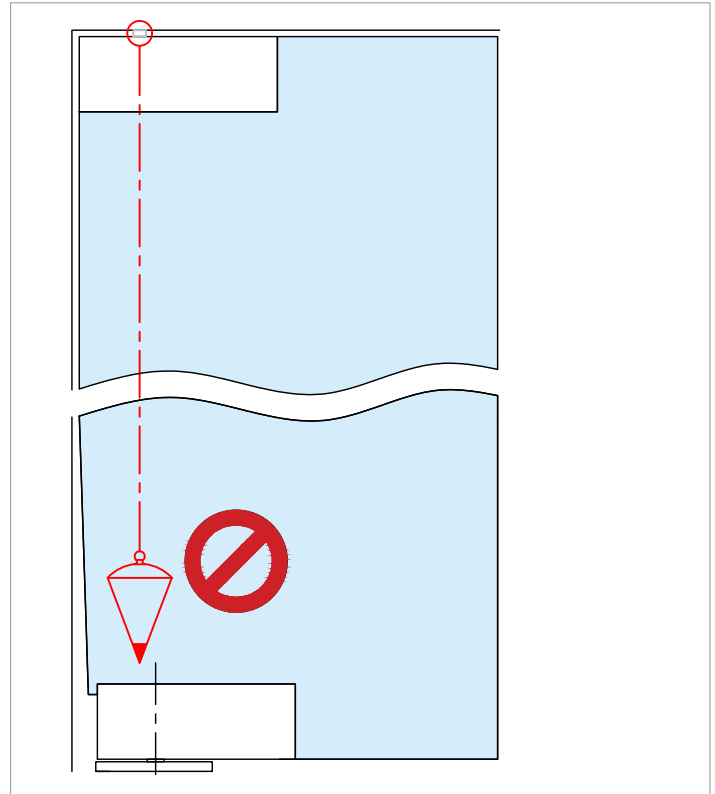
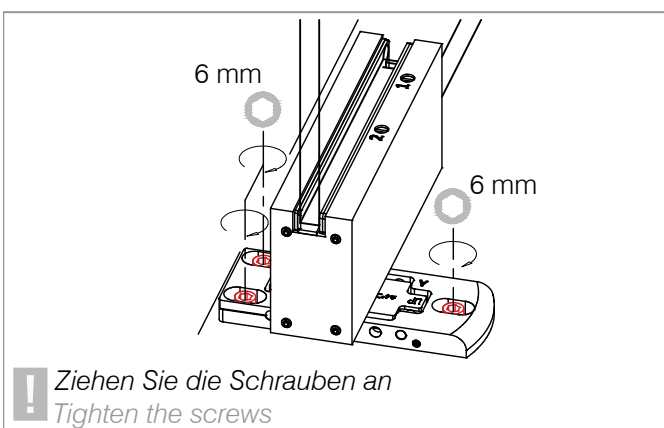
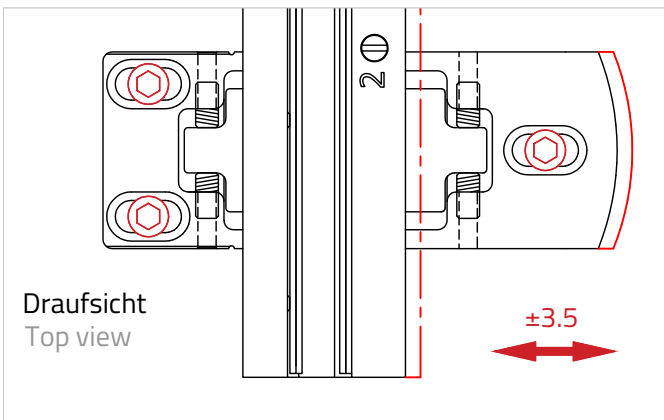
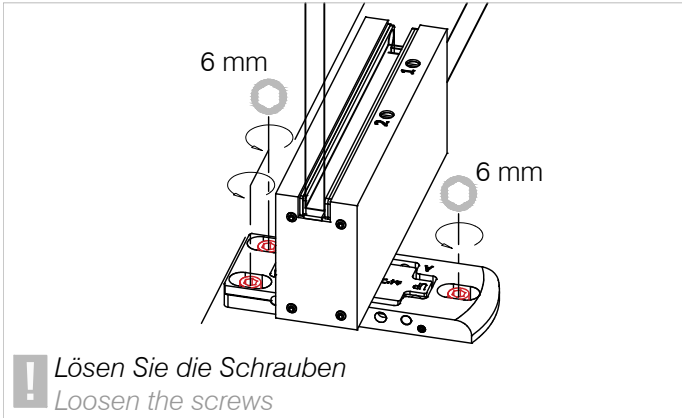

G-FITTINGS GmbH
Marie-Curie-Straße 16-18
46446 Emmerich am Rhein
T +49 (0)2822 962 0
F +49 (0)2822 962 221
E sales@g-fittings.com

4. Einstellung der 0° Stellung Mithilfe von Gewindestiften:
 4. Adjustment of the 0° position by means of set screws:

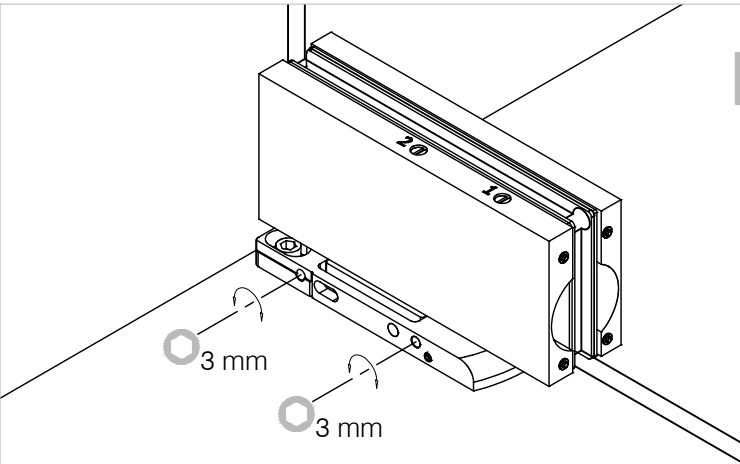

! An der Gegenüber Seite sind auch Einstellschrauben
 On the opposite side are also adjustment screws

Draufsicht
 Top view

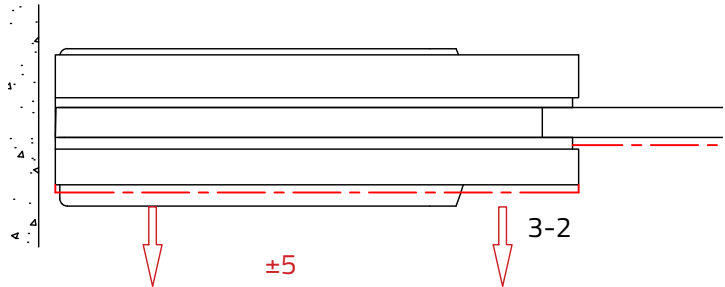
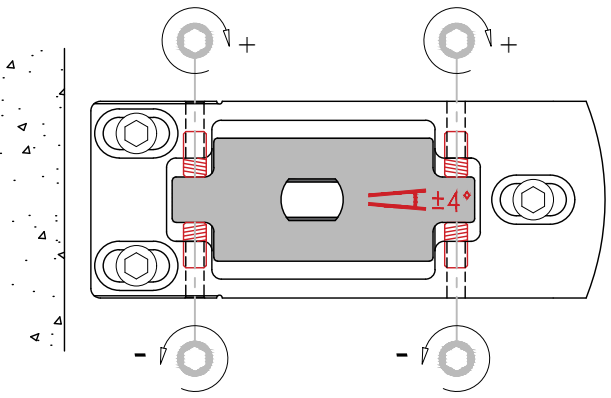
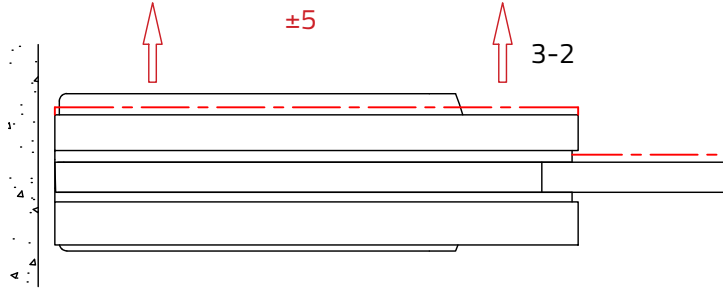
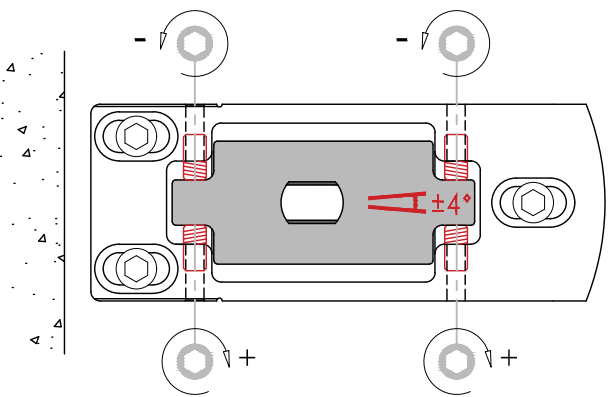

Art. 77450106000-12
Art. 77450106000-26

Draufsicht
Top view

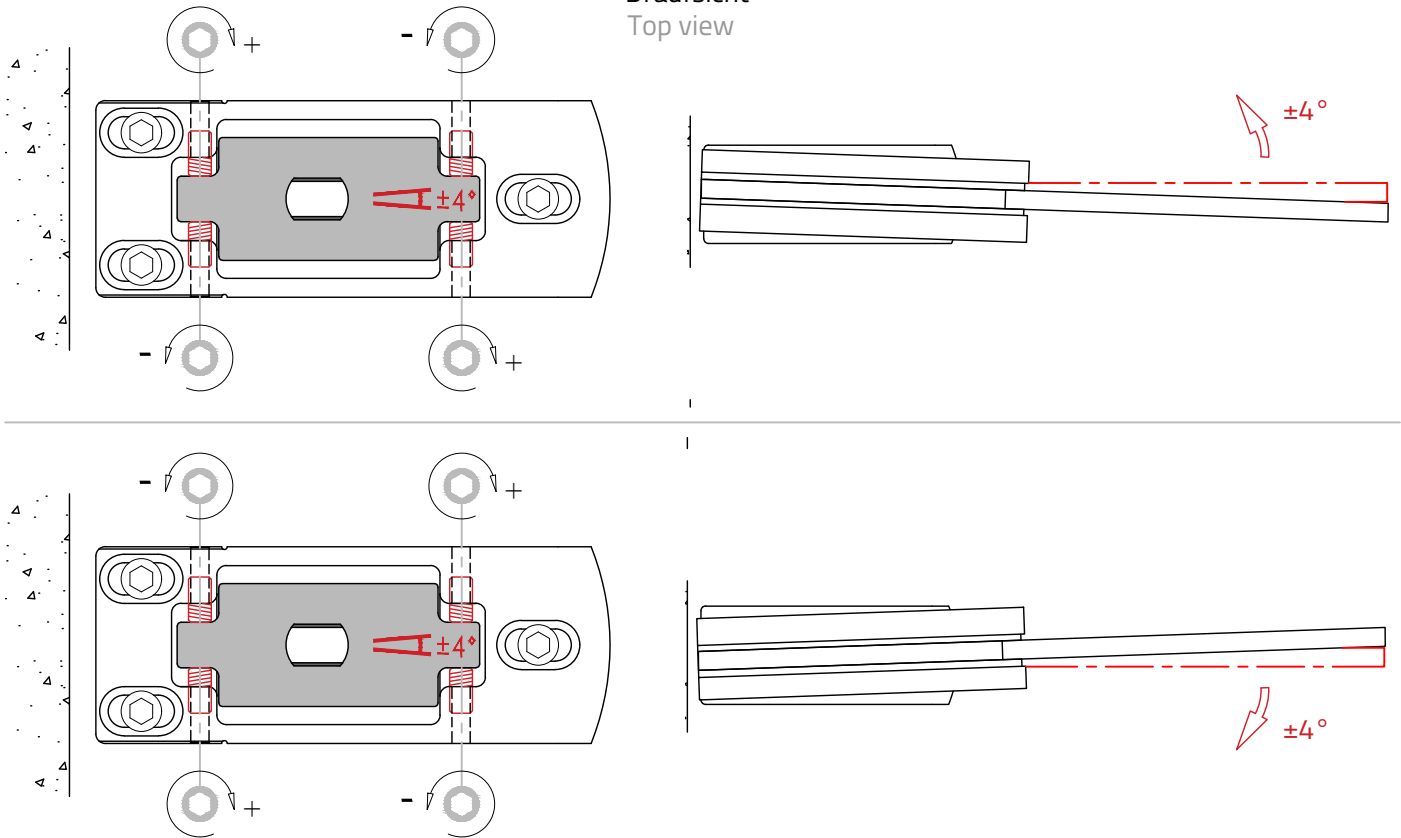

5. Einstellung der Schließkraft:

5. Closing force setting

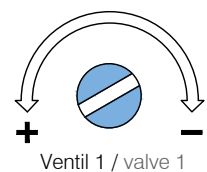
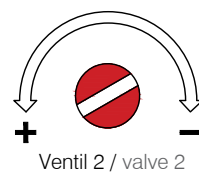
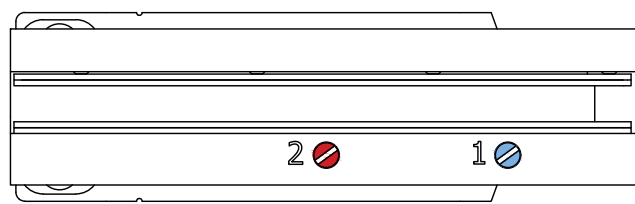
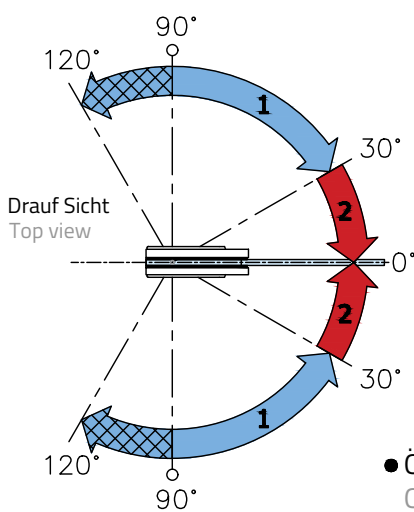

- Öffnungswinkel 120° für Beide Seiten
Opening angle 120° for both sides
- Tür hold-open funktion am 90° Winkel
Door hold-open function at 90° angle
- 2 Schließgeschwindigkeits Optionen
2 closing speed settings
Ventil 1: 90° - 30°
valve 1: 90° - 30°
Ventil 2: 30° - 0°
valve 2: 30° - 0°

! *Tip: Für eine letzte Feineinstellung reicht manchmal $\frac{1}{10}$ Umdrehung*
Tip: For a final fine adjustment sometimes $\frac{1}{10}$ turn is enough

Art. 77450106000-12
Art. 77450106000-26

6. Anbringung von Abdeckkappen
6. Attach cover caps

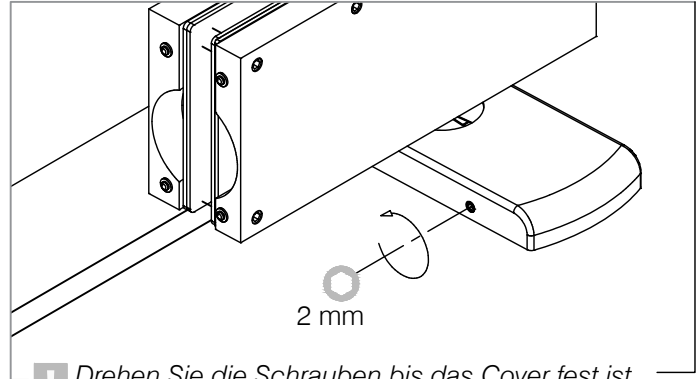
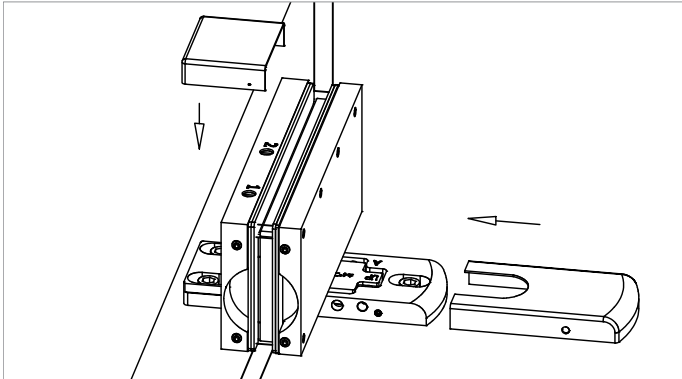

! Drehen Sie die Schrauben bis das Cover fest ist.
Auch die Gegenseite
Turn the screws until the cover is tight.
Also the opposite side

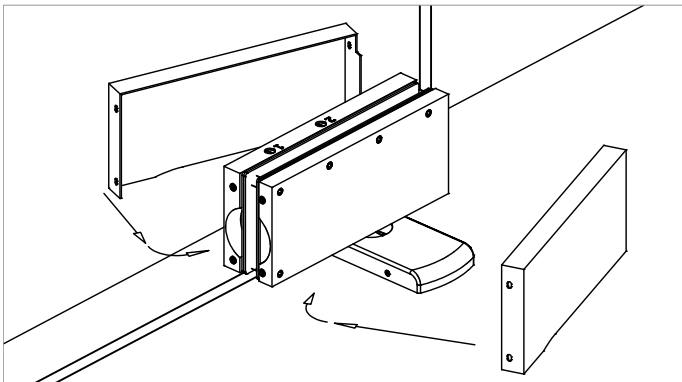

Achtung!
Schließen Sie die Tür nicht mit Kraft, dies kann zur Beschädigung im Inneren des Beschlages führen.
Note!
Do not close the door with force, this can lead to damage inside the fitting.