

Technische Daten:
hydraulisches Glastürschrnier - Liam

Datasheet:
hydraulic glass door hinge - Liam

Art. 77414512180-12
Art. 77414512180-26

Stand 06.2021

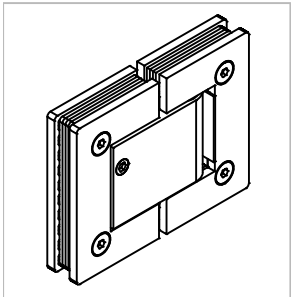

| | | | | |
|--------------------------------|--------------------------------|--|---------------------------------------|-----------------------------------|
| Ausführung: Options: | 8 mm - 10mm | 1000 mm max. | 45 kg max. | DIN links/left + DIN rechts/right |
| | Material: Material: | V2A Stainless steel AISI 304 | | Gewicht: / Weight: 1,2 kg |
| | Oberflächen: Finish: | Edelstahl-Design Stainless steel design | Anthrazit-Design Anthracite design | |

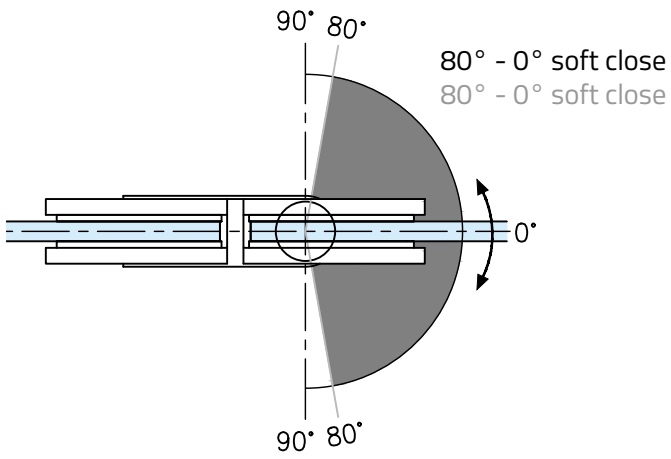
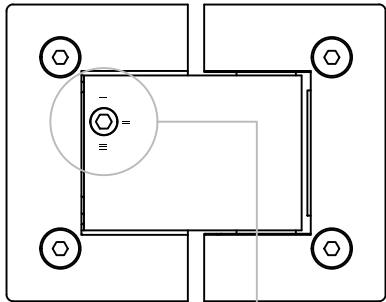
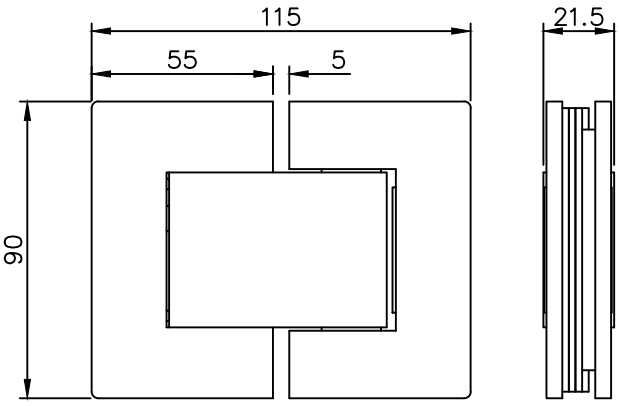

85° - 90° Feststellung:
85° - 90° Hold-open function

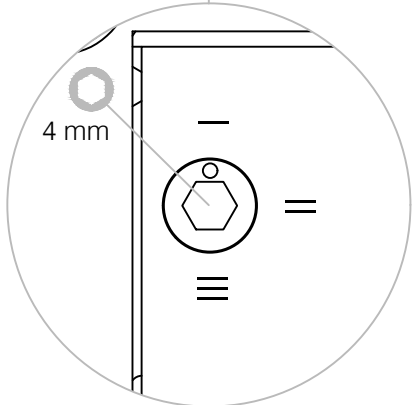

Einstellung der Kraft:
power adjustment:

Druckfehler und technische Änderungen vorbehalten / With reservation of printing errors and technical changes.

Art. 77414512180-12
Art. 77414512180-26

Glasbearbeitung:
Glass preparation:

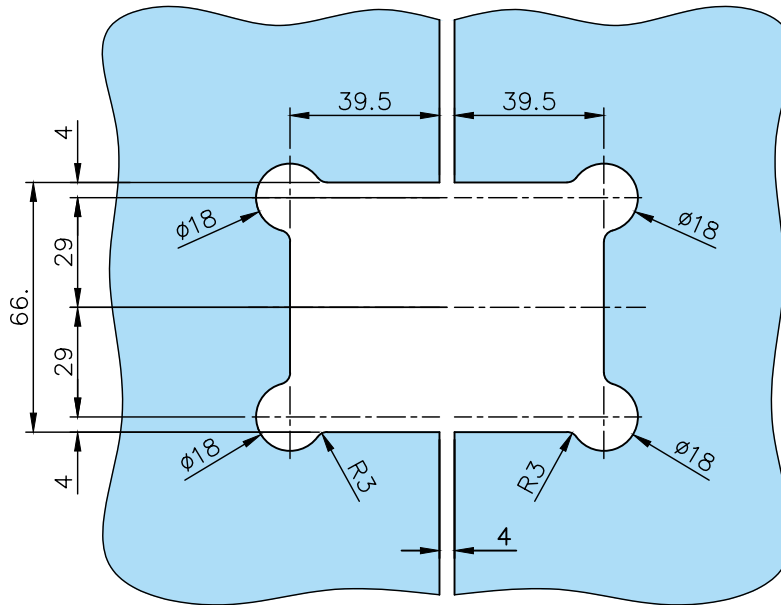

Zusammenbau:
Assembly:

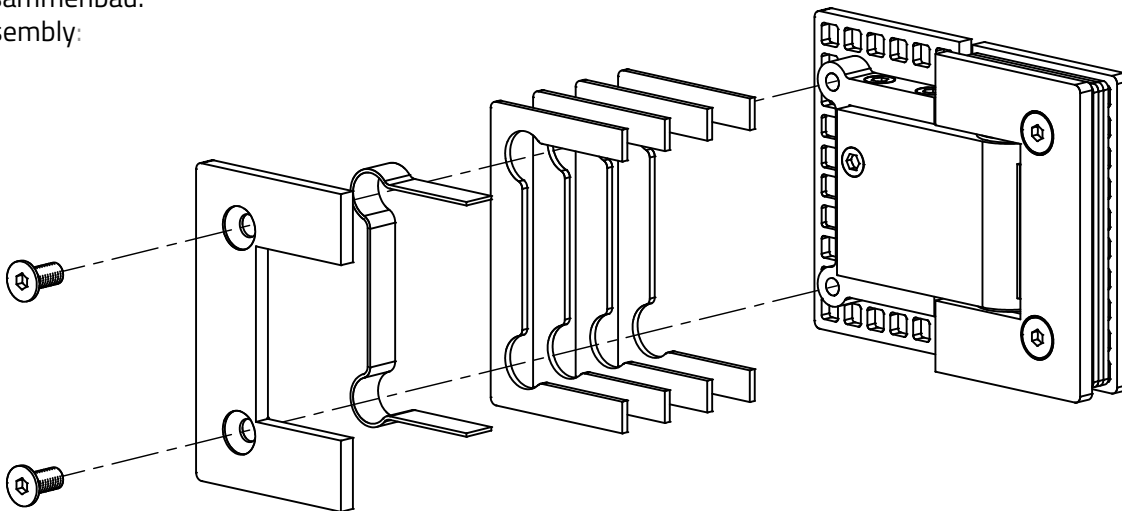

Art. 77414512180-12
Art. 77414512180-26

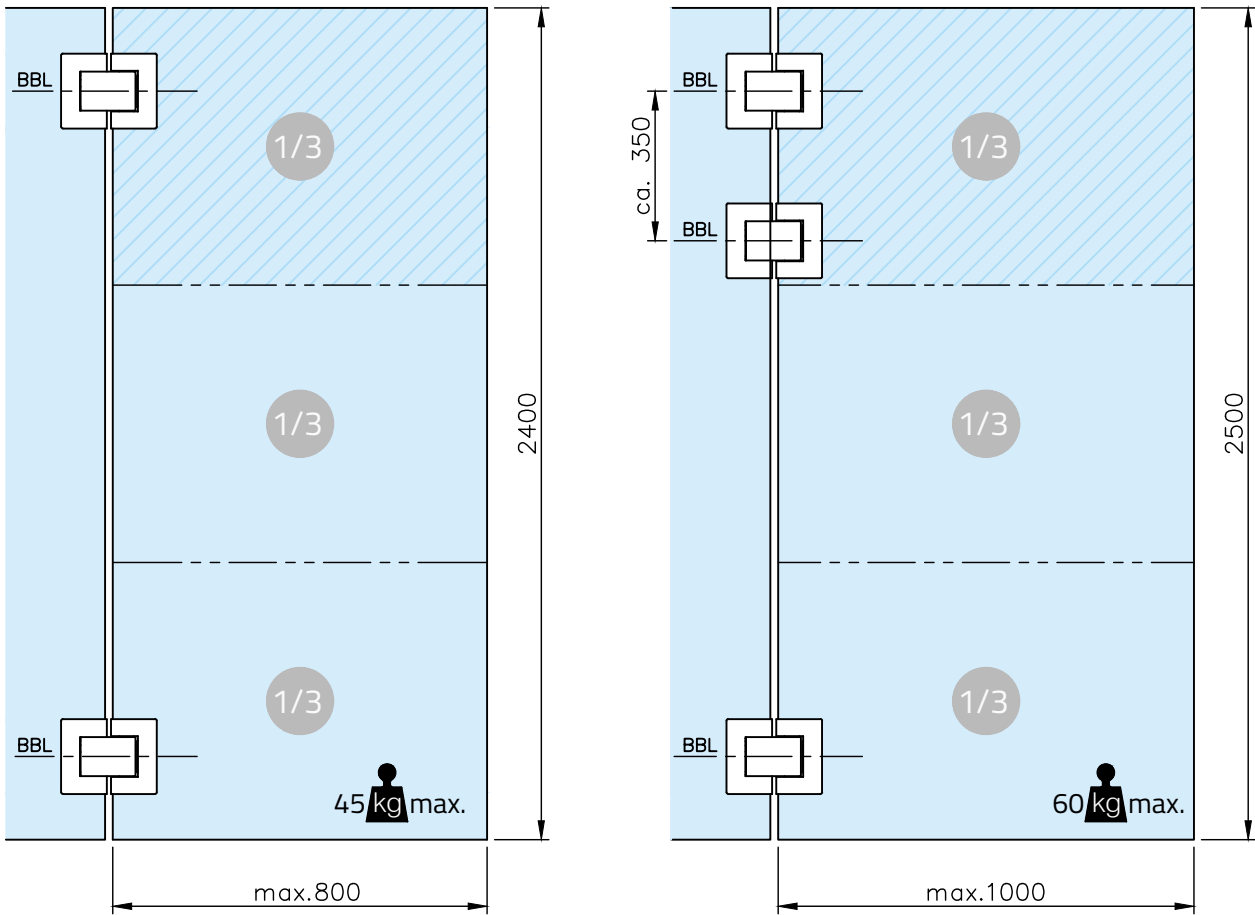

G-FITTINGS GmbH

Marie-Curie-Straße 16-18
46446 Emmerich am Rhein
T +49 (0)2822 962 0
E sales@g-fittings.com

(no scaled view)